

Proton24 PIC24 BASIC Compiler

A Powerful BASIC Compiler for PIC24 and dsPIC Devices

Written By Les Johnson

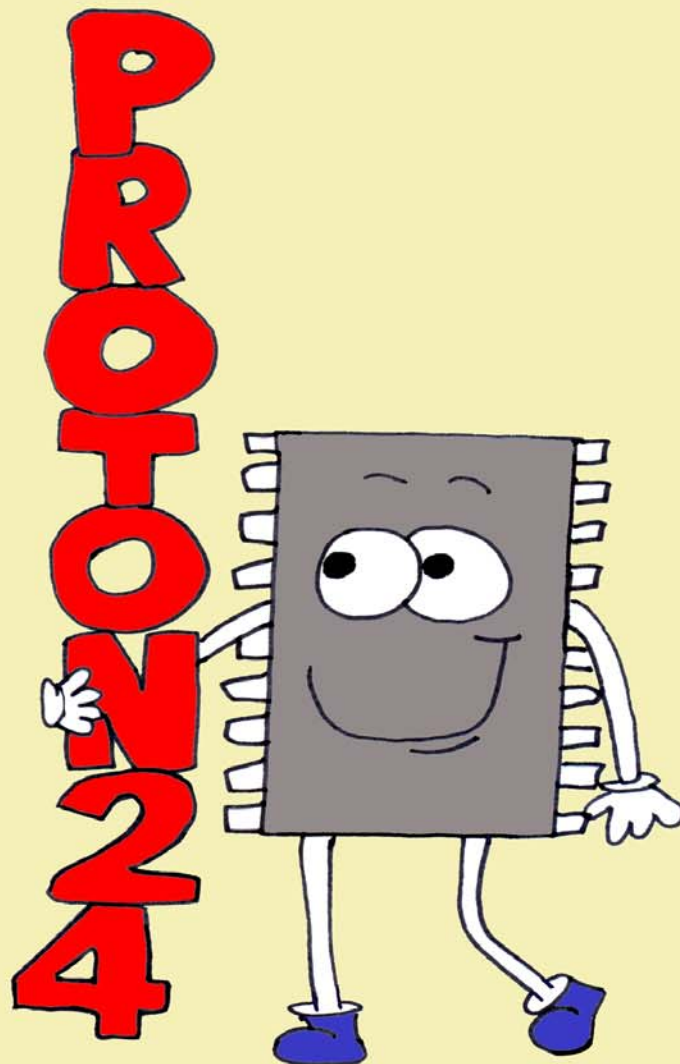

Rosetta Technologies and Crownhill Associates reserve the right to make changes to the products contained in this publication in order to improve design, performance or reliability. Except for the limited warranty covering a physical CD-ROM and/or Hardware License key supplied with this publication as provided in the End-User License agreement, the information and material content of this publication are provided “as is” without warranty of any kind express or implied including without limitation any warranty concerning the accuracy adequacy or completeness of such information or material or the results to be obtained from using such information or material. Neither Crownhill Associates Limited or Rosetta Technologies or the author shall be responsible for any claims attributable to errors omissions or other inaccuracies in the information or materials contained in this publication and in no event shall Crownhill Associates or the author be liable for direct indirect or special incidental or consequential damages arising out of the use of such information or material. Neither Crownhill or the author convey any license under any patent or other right, and make no representation that the circuits are free of patent infringement. Charts and schedules contained herein reflect representative operating parameters, and may vary depending upon a user’s specific application.

All terms mentioned in this manual that are known to be trademarks or service marks have been appropriately marked. Use of a term in this publication should not be regarded as affecting the validity of any trademark.

PICmicro[™] is a trade name of Microchip Technologies Inc. www.microchip.com

Proton[™] is a trade name of Rosetta Technologies and Crownhill Associates Ltd.
www.crownhill.co.uk

Proton24[™] is a trade name of Rosetta Technologies and Crownhill Associates Ltd.
www.crownhill.co.uk

EPIC[™] is a trade name of microEngineering Labs Inc. www.microengineeringlabs.com

The Proton IDE was written by David Barker of Mecanique www.mecanique.co.uk

Proteus VSM © Copyright Labcenter Electronics Ltd www.labcenter.co.uk

Title image by Amie Reynolds.

Web URLs correct at time of publication.

The Proton compiler and documentation is written by Les Johnson.

If you should find any anomalies or omission in this document, please contact us, as we appreciate your assistance in improving our products and services.

First published by Crownhill Associates Limited, Cambridge, England, 2012.

Introduction

The Proton24 compiler was written with simplicity and flexibility in mind. Using BASIC, which is almost certainly the easiest programming language around, you can now produce extremely powerful applications for your microcontroller without having to learn the relative complexity of assembler, or wade through the potential gibberish that is C.

The Proton IDE provides a seamless development environment, which allows you to write and compile your code within the same Windows environment, and by using a compatible programmer, just one key press allows you to program and verify the resulting code.

The Proton24 compiler allows several devices without requiring a USB key. The supported free devices are: **PIC24EP128MC202**, **PIC24FJ64GA002**, **PIC24FJ64GA004**, **PIC24HJ128GP502**, **PIC24F04KL101**, and **dsPIC33FJ128GP802**. These will be increased in time, and the most popular devices on the market will be added as free devices.

Contact Details

For your convenience we have set up a web site **www.protonbasic.co.uk**, where there is a section for users of the Proton24 compiler, to discuss the compiler, and provide self help with programs written for Proton24 BASIC, or download sample programs. The web site is well worth a visit now and then, either to learn a bit about how other peoples code works or to request help should you encounter any problems with programs that you have written.

Should you need to get in touch with us for any reason our details are as follows: -

Postal

Crownhill Associates Limited.
Old Station Yard,
Station Road,
Wilburton,
Ely,
Cambridgeshire.
CB6 3PZ.

Telephone

(+44) 01353 749990

Fax

(+44) 01353 749991

Email

sales@crownhill.co.uk

Web Sites

<http://www.crownhill.co.uk>

<http://www.protonbasic.co.uk>

Table of Contents.

Proton24 Compiler Overview	12
Identifiers	12
Line Labels	12
Ports and other SFRs	13
PPS_Input (pPin, pFunction)	13
PPS_Output(pPin, pFunction)	14
PPS_Lock()	14
PPS_UnLock()	14
Numeric Representations	15
Quoted String of Characters	15
Standard Variables	16
32-bit and 64-bit Floating Point Maths	19
Floating Point To Integer Rounding	22
Floating Point Exception Flags	23
Aliases	24
Finer points of variable handling	26
Symbols	29
Creating and using Arrays	30
Finer points of array variables	35
Creating and using String variables	36
Procedures	43
Parameters	43
Local Variable and Label Names	44
Return Variable	44
A Typical Flat BASIC Program Layout	48
A Typical Procedural BASIC Program Layout	49
General Format	50
Line Continuation Character '_'	50
Creating and using Code Memory Tables	51
String Comparisons	53
Relational Operators	56
Boolean Logic Operators	57

Math Operators	58
Abs	72
fAbs	73
dAbs	74
Acos	75
dAcos	76
Asin.....	77
dAsin.....	78
Atan	79
dAtan	80
Atan2	81
dAtan2	82
Ceil	83
dCeil.....	84
Cos	85
dCos.....	86
Dcd	87
Dig '?'	87
Exp	88
dExp	89
Floor	90
dFloor.....	91
fRound	92
dRound	93
ISin	94
ICos	95
Isqr.....	96
Log	97
dLog.....	98
Log10.....	99
dLog10.....	100
Modf	101
Modd.....	102
Ncd	103
Pow.....	104

dPow.....	105
Rev '@'.....	106
Sin.....	107
dSin.....	108
Sqr.....	109
dSqr.....	110
Tan.....	111
dTan.....	112
Compiler Commands and Directives	113
Adin.....	117
Asm..EndAsm.....	119
Box.....	120
Branch.....	123
BranchL.....	125
Break.....	126
Bstart.....	128
Bstop.....	129
Brestart.....	129
BusAck.....	129
BusNack.....	129
Busin.....	130
Busout.....	133
Button.....	137
Call.....	139
Cdata.....	140
Circle.....	143
Clear.....	146
ClearBit.....	147
ClearPin.....	148
Cls.....	150
Config.....	152
Continue.....	157
Counter.....	158
cPtr8, cPtr16, cPtr32, cPtr64.....	159
Cread8, Cread16, Cread32, Cread64.....	161

Cursor	163
Dec	165
Declare.....	166
Misc Declares.	166
Adin Declares.	168
Busin - Busout Declares.....	169
Hbusin - Hbusout Declares.....	169
USART1 Declares for Hserin, Hserout, Hrsin and Hrsout.	170
USART2 Declares for use with Hrsin2, Hserin2, Hrsout2 and Hserout2.	171
USART3 Declares for use with Hrsin3, Hserin3, Hrsout3 and Hserout3.	172
USART4 Declares for use with Hrsin4, Hserin4, Hrsout4 and Hserout4.	173
Hpwmm Declares.....	173
Alphanumeric (Hitachi HD44780) LCD Print Declares.	174
Graphic LCD Declares.	176
KS0108 Graphic LCD specific Declares.	176
Toshiba T6963C Graphic LCD specific Declares.	177
ILI9320 Colour Graphic LCD specific Declares.	179
ADS7846 Touch Screen controller Declares.	180
Keypad Declare.....	180
Rsin - Rsout Declares.	180
Serin - Serout Declare.	182
Shin - Shout Declare.	183
Stack Declares.	183
Oscillator Frequency Declare.	184
DelayCs	187
DelayMs	188
DelayUs	189
Device	190
Dig.....	191
Dim.....	192
Creating Code Memory Tables using Dim	196
Creating variables in Y RAM	196
Creating variables in DMA RAM	197
Do...Loop.....	199
DTMFout	201
Edata	202
End	207
Eread	208
Ewrite.....	209
For...Next...Step.....	210
Freqout	212
GetBit	214
GetPin	215
Gosub	216
GoTo.....	217

HbStart.....	218
HbStop.....	219
HbRestart	219
HbusAck	219
HbusNack	219
Hbusin.....	220
Hbusout	223
High.....	227
Hpwm	229
Hrsin, Hrsin2, Hrsin3, Hrsin4	230
Hrsout, Hrsout2, Hrsout3, Hrsout4.....	238
HrsoutLn, Hrsout2Ln, Hrsout3Ln, Hrsout4Ln	244
Hserin, Hserin2, Hserin3, Hserin4	245
Hserout, Hserout2, Hserout3, Hserout4	250
HseroutLn, Hserout2Ln, Hserout3Ln, Hserout4Ln	254
HSerial1_ChangeBaud.....	255
HSerial2_ChangeBaud.....	256
HSerial3_ChangeBaud.....	257
HSerial4_ChangeBaud.....	258
I2Cin.....	259
I2Cout.....	261
If..Then..Elseif..Else..EndIf	264
Include.....	266
Inc.....	268
Inkey	269
Input.....	270
Isr, EndIsr	272
LCDread	276
LCDwrite	278
Len	281
Left\$	283
Line.....	285
LineTo.....	288
LoadBit.....	289
LookDown	290
LookDownL.....	291

LookUp.....	292
LookUpL.....	293
Low.....	294
Mid\$.....	296
On GoTo.....	298
On Gosub.....	300
Output.....	302
Oread.....	303
Owrite.....	307
Pixel.....	309
Plot.....	310
Pop.....	313
Pot.....	315
Print.....	316
Using a KS0108 Graphic LCD.....	321
Using a Toshiba T6963 Graphic LCD.....	324
Using an ILI9320 320x240 pixel Colour Graphic LCD.....	327
Ptr8, Ptr16, Ptr32, Ptr64.....	331
PulseIn.....	334
PulseOut.....	335
Push.....	336
Pwm.....	340
Random.....	341
RCin.....	342
Repeat...Until.....	344
Return.....	345
Right\$.....	346
Rol.....	348
Ror.....	350
Rsin.....	352
Rsout.....	357
RsoutLn.....	362
Seed.....	363
Select..Case..EndSelect.....	364
Servo.....	366
SetBit.....	368
SetPin.....	369

Set	371
Shin	372
Shout	374
Sleep.....	376
Sound	377
Stop	378
Strn.....	379
Str\$.....	380
Swap.....	382
Symbol.....	383
Toggle.....	384
ToLower	385
ToUpper	387
Touch_Active	389
Touch_Read.....	391
Touch_HotSpot	393
Toshiba_Command.....	395
Toshiba_UDG.....	398
UnPlot	400
Val	401
AddressOf.....	403
While...Wend	404
Using the Preprocessor	405
Preprocessor Directives.....	405
Conditional Directives (\$ifdef, \$ifndef, \$if, \$endif, \$else and \$elseif)	408

Proton IDE Overview	412
Menu Bar	413
Main Toolbar	414
Edit Toolbar	415
Code Explorer	417
Results View	418
Editor Options	420
Highlighter Options.....	422
Compile and Program Options	424
Installing a Programmer.....	425
Creating a custom Programmer Entry.....	426
IDE Plugins	428
ASCII Table	429
Hex View	429
Assembler Window	430
Assembler Main Toolbar	431
Assembler Editor Options	432
Serial Communicator.....	433
Serial Communicator Main Toolbar	434
Protected Proton24 Compiler Words	438

Proton24 Compiler Overview

This manual is not intended to give details about individual microcontroller devices, therefore, for further information visit the Microchip™ website at www.microchip.com, and download the multitude of datasheets and application notes available.

Most PIC24® and dsPIC33® devices have analogue comparators and ADCs etc. When these devices first power up, the pin is set to analogue mode, which makes the pin functions work in a strange manner. To change the pins to digital, the appropriate SFRs (Special Function Registers) must be manipulated near the front of your BASIC program, or before any of the pins are accessed. The SFRs in question do have a commonality between devices, however, there are sometimes subtle differences, therefore, always read the datasheet for the device being used.

The compiler attempts to make all pins digital by manipulating the required SFRs before the user's program starts. This is accomplished within each device's ".def" file. However, this is not foolproof and some peripherals may slip through. Users are requested to inform the forum if any extra SFRs are required for a particular device, and these will be added in a later update of the compiler.

All of the microcontroller's pins are set to inputs on power-up. Once again, always read the datasheets to become familiar with the particular device being used.

Devices containing PPS (Peripheral Pin Sharing) have the ability to choose the pins used by certain peripherals. There are dedicated SFRs for PPS that must be manipulated correctly otherwise the peripheral in question will not work. See the ports section of this manual

Identifiers

An identifier is a technical term for a name. Identifiers are used for line labels, variable names, and constant aliases. An identifier is any sequence of letters, digits, and underscores, although it must not start with a digit. Identifiers are not case sensitive, therefore label, LABEL, and Label are all treated as equivalent. Identifiers have a maximum length of 100 characters. Any identifier that breaks the 100 character limit will cause a syntax error message.

Line Labels

In order to mark statements that the program may wish to reference with the **GoTo**, **Call**, or **Gosub** commands, the compiler uses line labels. Unlike many older BASICs, the compiler does not allow or require line numbers and doesn't require that each line be labelled. Instead, any line may start with a line label, which is simply an identifier followed by a colon ':'.
Label:

```
Print "Hello World"  
GoTo Label
```

Ports and other SFRs

All of the microcontroller's SFRs (Special Function Registers), including the ports, can be accessed just like any other variable. This means that they can be read from, written to, or used in expressions directly.

```
PORTB = %0101010101010101    ' Write value to PORTB

Var1 = MyWord * PORTB ' Multiply variable MyWord with contents of PORTB
```

Remember, unlike the 8-bit microcontroller's, PIC24[®] and dsPIC33[®] devices have 16-bit wide ports and SFRs.

One thing that can affect the operation of a port when used for a peripheral is PPS (Peripheral Pin Select). Most of the newer PIC24[®] and dsPIC33[®] devices have PPS which means that there is not a dedicated pin for a specific peripheral. i.e. the USART, and its pins must be designated before the peripheral can be used. The subject of PPS is too detailed for this manual, however, Microchip[™] have several reference manuals that cover the use of PPS. "PIC24F[®] Family Reference Manual - Sect 12 - I/O" being one of them and has the file title "39711b.pdf". It is very important to read the device's datasheet and understand the operation of PPS in order for a peripheral to work correctly.

Within this manual there are several examples that use the line of code:

```
RPOR7 = 3                ' Make PPS Pin RP14 U1TX
```

The above code designates pin RB14 (**PORTB.14**) for use as the TX pin for USART1.

The compiler has helper macros built in for Peripheral Pin Select, these are **PPS_Input**, **PPS_Output**, **PPS_Unlock**, and **PPS_Lock**. The macros and the related defines can be found within each device's **.def** file, located within the compiler's Def directory. Below, is a brief explanation of the macros, but this is not a substitute for reading the device's datasheet.

The PPS (Peripheral Pin Select) feature provides a method of enabling the user's peripheral set selection and their placement on a wide range of I/O pins. By increasing the pinout options available on a particular device, users can better tailor the microcontroller to their application, rather than trimming the application to fit the device.

The PPS feature operates over a fixed subset of digital I/O pins. Users may independently map the input and/or output of any one of many digital peripherals to any one of these I/O pins. PPS is performed in software and generally does not require the device to be reprogrammed. Optional hardware safeguards are included that prevent accidental or spurious changes to the peripheral mapping once it has been established.

Example.

```
PPS_Output(cOut_Pin_RP35, cOut_Fn_U1TX)    ' Map UART1 TX pin to RP35
PPS_Input(cIn_Pin_RPI34, cIn_Fn_U1RX)     ' Map UART1 RX pin to RPI34
```

PPS_Input (pPin, pFunction)

The **PPS_Input** macro assigns a given pin as input by configuring register RPINRx.

Not all devices use the same values for assigning pins to PPS, therefore, the parameters to use within the macros can be found in each device's **.def** file.

PPS_Output(pPin, pFunction)

The **PPS_Output** macro assigns a given pin as output by configuring register RPORx.

Not all devices use the same values for assigning pins to PPS, therefore, the parameters to use within the macros can be found in each device's .def file.

PPS_Lock()

The **PPS_Lock** macro performs the locking sequence for PPS assignment.

Note that this is only required if the *IOL1WAY_OFF* fuse setting is not preset within the device's configs. The compiler defaults to **not** requiring the PPS_Lock macro when manipulating PPS.

PPS_UnLock()

The **PPS_Unlock** macro performs the unlocking sequence for PPS assignment.

Note that this is only required if the *IOL1WAY_OFF* fuse setting is not preset within the device's configs. The compiler defaults to **not** requiring the PPS_Lock macro when manipulating PPS.

Numeric Representations

The compiler recognises several different numeric representations: -

Binary is prefixed by %. i.e. `%01000101`

Hexadecimal is prefixed by \$ or 0x. i.e. `$0A` or `0x0A`

Character byte is surrounded by quotes. i.e. `"a"` represents a value of `97`

Decimal values need no prefix.

Floating point is created by using a decimal point. i.e. `3.14`

Quoted String of Characters

A Quoted String of Characters contains one or more characters (maximum 8192) and is delimited by double quotes. Such as `"Hello World"`

The compiler also supports a subset of C language type formatters within a quoted string of characters. These are: -

<code>\a</code>	Bell (alert) character	<code>\$07</code>
<code>\b</code>	Backspace character	<code>\$08</code>
<code>\f</code>	Form feed character	<code>\$0C</code>
<code>\n</code>	New line character	<code>\$0A</code>
<code>\r</code>	Carriage return character	<code>\$0D</code>
<code>\t</code>	Horizontal tab character	<code>\$09</code>
<code>\v</code>	Vertical tab character	<code>\$0B</code>
<code>\\</code>	Backslash	<code>\$5C</code>
<code>\"</code>	Double quote character	<code>\$22</code>

Example: -

```
Print "\"Hello World\"\\n\\r"
```

Quoted strings of characters are usually treated as a list of individual character values, and are used by commands such as **Print**, **Rsout**, **Busout**, **Ewrite** etc. And of course, **String** variables.

Null Terminated

Null is a term used in computer languages for zero. So a null terminated string is a collection of characters followed by a zero in order to signify the end of characters. For example, the string of characters "Hello", would be stored as: -

```
"H", "e", "l", "l", "o", 0
```

Notice that the terminating null is the value 0 not the character "0".

Standard Variables

Variables are where temporary data is stored in a BASIC program. They are created using the **Dim** keyword. Because X RAM space on microcontrollers can be somewhat limited, choosing the right size variable for a specific task is important. Variables may be **Bits**, **Bytes**, **Words**, **Dwords**, **SBytes**, **SWords**, **SDwords**, **Floats** or **Double**.

Space for each variable is automatically allocated in the microcontroller's X RAM area. The format for creating a variable is as follows: -

Dim Name as Size

Name is any identifier, (excluding keywords). *Size* is **Bit**, **Byte**, **Word**, **Dword**, **SByte**, **SWord**, **SDword** or **Float**. Some examples of creating variables are: -

```
Dim Cat as Bit           ' Create a single bit variable (0 or 1)
Dim Dog as Byte         ' Create an 8-bit unsigned variable (0 to 255)
Dim Rat as Word         ' Create a 16-bit unsigned variable (0 to 65535)
Dim Lrg_Rat as Dword    ' Create a 32-bit unsigned variable (0 to
                        ' 4294967295)

Dim sDog as SByte       ' Create an 8-bit signed variable (-128 to +127)
Dim sRat as SWord       ' Create a 16-bit signed variable (-32768 to +32767)
Dim sLrg_Rat as SDword  ' Create a 32-bit signed variable (-2147483648 to
                        ' +2147483647)

Dim Pointy_Rat as Float ' Create a 32-bit floating point variable
Dim Pointy_Lrg_Rat as Double ' Create a 64-bit floating point variable
```

The number of variables available depends on the amount of RAM on a particular device and the size of the variables within the BASIC program. The compiler will reserve RAM for its own use and may also create additional (System) variables for use when calculating expressions, or more complex command structures.

Intuitive Variable Handling.

The compiler handles its System variables intuitively, in that it only creates those that it requires. Each of the compiler's built in library subroutines i.e. **Print**, **Rsout** etc, may require a certain amount of System RAM as internal variables.

The compiler will increase its System RAM requirements as programs get larger, or more complex structures are used, such as complex expressions, inline commands used in conditions, Boolean logic used etc. However, with the limited RAM space available on some devices, every byte counts.

There are certain reserved words that cannot be used as variable names, these are the system variables used by the compiler.

The following reserved words should not be used as variable names, as the compiler will create these names when required: -

```
PP0, PP0H, PP1, PP1H, PP2, PP2H, PP3, PP3H, PP4, PP4H, PP5, PP5H, PP6, PP6H,
PP7, PP7H, PP8, PP9H, GEN, GENH, GEN2, GEN2H, PRTA1, PRTA1H, PRTA2, PRTA2H,
PINM1, PINM1H, PINM2, PINM2H, BPF, BPFH.
```

However, if a compiler system variable is to be brought into the BASIC program for a specific reason, the reserved variables can be used, but must always be declared as a **Word** type.

RAM space required.

Each type of variable requires differing amounts of RAM memory for its allocation. The list below illustrates this.

- **Double** Requires 8 bytes of RAM.
- **Float** Requires 4 bytes of RAM.
- **Dword** Requires 4 bytes of RAM.
- **SDword** Requires 4 bytes of RAM.
- **Word** Requires 2 bytes of RAM.
- **SWord** Requires 2 bytes of RAM.
- **Byte** Requires 1 byte of RAM.
- **SByte** Requires 1 byte of RAM.
- **Bit** Requires 1 byte of RAM for every 8 **Bit** variables created.

Each type of variable may hold a different minimum and maximum value.

- **Bit** type variables may hold a 0 or a 1. These are created 8 at a time, therefore declaring a single **Bit** type variable in a program will not save RAM space, but it will save code space, because **Bit** type variables produce the most efficient use of code for comparisons etc.
- **Byte** type variables may hold an unsigned value from 0 to 255, and are the usual work horses of most programs. Code produced for **Byte** sized variables is very low compared to signed or unsigned **Word**, **DWord** or **Float** types, and should be chosen if the program requires faster, or more efficient operation.
- **SByte** type variables may hold a 2^{15} complemented signed value from -128 to +127. Code produced for **SByte** sized variables is very low compared to **SWord**, **Float**, or **SDword** types, and should be chosen if the program requires faster, or more efficient operation. However, code produced is usually larger for signed variables than unsigned types.
- **Word** type variables may hold an unsigned value from 0 to 65535, which is usually large enough for most applications. It still uses more memory than an 8-bit byte variable, but not nearly as much as a **Dword** or **SDword** type.
- **SWord** type variables may hold a 2^{15} complemented signed value from -32768 to +32767, which is usually large enough for most applications. **SWord** type variables will use more code space for expressions and comparisons, therefore, only use signed variables when required.
- **Dword** type variables may hold an unsigned value from 0 to 4294967295 making this the largest of the variable family types. This comes at a price however, as **Dword** calculations and comparisons will use more code space within the microcontroller Use this type of variable sparingly, and only when necessary.
- **SDword** type variables may hold a 2^{15} complemented signed value from -2147483648 to +2147483647, also making this the largest of the variable family types. This comes at a price however, as **SDword** expressions and comparisons will use more code space than a regular **Dword** type. Use this type of variable sparingly, and only when necessary.

- **Float** type variables may theoretically hold a value from $-1e37$ to $+1e38$, but because of the 32-bit architecture of the compiler, a maximum and minimum value should be thought of as -2147483646.999 to $+2147483646.999$ making this one of the most versatile of the variable family types. However, more so than **Dword** types, this comes at a price because 32-bit floating point expressions and comparisons will use more code space within the microcontroller. Use this type of variable sparingly, and only when strictly necessary. Smaller floating point values usually offer more accuracy.
- **Double** type variables may hold a value larger than **Float** types, and with some extra accuracy, but because of the 32-bit architecture of the compiler, a maximum and minimum value should be thought of as -2147483646.999 to $+2147483646.999$ making this one of the most versatile of the variable family types. However, more so than **Dword** and **Float** types, this comes at a price because 64-bit floating point expressions and comparisons will use more code space within the microcontroller. Use this type of variable sparingly, and only when strictly necessary. Smaller floating point values usually offer more accuracy.

Notes.

The final RAM usage will also encompass the microcontroller's stack size, therefore, even if the BASIC program only declares 4 **Byte** variables, the final RAM count will be 124. 120 bytes for the default stack size and 4 bytes for variable usage. If handled interrupts are used, the stack size will increase due to context saving and restoring requirements.

See also : [Aliases](#), [Arrays](#), [Dim](#), [Symbol](#), [Floating Point Math](#).

32-bit Floating Point Example Programs.

```
' Multiply two floating point values
Device = 24FJ64GA002
Declare Xtal = 16
Declare Hserial_Baud = 9600      ' USART1 baud rate
Declare Hrsout1_Pin = PORTB.14  ' Select the pin for TX with USART1

Dim MyFloat as Float
Symbol FlNum = 1.234            ' Create a floating point constant value

RPOR7 = 3                      ' Make PPS Pin RP14 U1TX
MyFloat = FlNum * 10
Hrsout Dec MyFloat, 13
Stop

' Add two floating point variables
Device = 24FJ64GA002
Declare Xtal = 16
Declare Hserial_Baud = 9600      ' USART1 baud rate
Declare Hrsout1_Pin = PORTB.14  ' Select the pin for TX with USART1

Dim MyFloat as Float
Dim MyFloat1 as Float
Dim MyFloat2 as Float

RPOR7 = 3                      ' Make PPS Pin RP14 U1TX
MyFloat1 = 1.23
MyFloat2 = 1000.1
MyFloat = MyFloat1 + MyFloat2
HrsoutLn Dec MyFloat
Stop

' A digital volt meter, using the on-board 10-bit ADC
Device = 24FJ64GA002
Declare Xtal = 16
Declare Hserial_Baud = 9600      ' USART1 baud rate
Declare Hrsout1_Pin = PORTB.14  ' Select the pin for TX with USART1

Declare Adin_Tad = cFRC          ' RC OSC chosen
Declare Adin_Delay = 10         ' Allow 10us sample time

Dim wRaw as Word
Dim fVolts as Float
Symbol Quanta = 3.3 / 1024      ' Calculate the quantising value for 10-bits

RPOR7 = 3                      ' Make PPS Pin RP14 U1TX
AD1CON2 = 0                    ' +Vref = AVdd, -Vref = AVss
AD1PCFGbits_PCFG0 = 0         ' Analogue input on AN0
While
    wRaw = Adin 0
    fVolts = wRaw * Quanta
    HrsoutLn Dec2 fVolts, "V"
    DelayMs 300
Wend
```

64-bit Floating Point Example Programs.

```
' Multiply two 64-bit floating point values
Device = 24FJ64GA002
Declare Xtal = 16
Declare Hserial_Baud = 9600      ' USART1 baud rate
Declare Hrsout1_Pin = PORTB.14  ' Select the pin for TX with USART1

Dim MyDouble as Double
Symbol FlNum = 1.234            ' Create a floating point constant value

RPOR7 = 3                       ' Make PPS Pin RP14 U1TX
MyDouble = FlNum * 10
Hrsout Dec MyDouble, 13
Stop

' Add two 64-bit floating point variables
Device = 24FJ64GA002
Declare Xtal = 16
Declare Hserial_Baud = 9600      ' USART1 baud rate
Declare Hrsout1_Pin = PORTB.14  ' Select the pin for TX with USART1

Dim MyDouble as Double
Dim MyDouble 1 as Double
Dim MyDouble 2 as Double

RPOR7 = 3                       ' Make PPS Pin RP14 U1TX
MyDouble1 = 1.23
MyDouble2 = 1000.1
MyDouble = MyDouble1 + MyDouble2
HrsoutLn Dec MyDouble
Stop

' A digital volt meter, using the on-board 10-bit ADC
Device = 24FJ64GA002
Declare Xtal = 16
Declare Hserial_Baud = 9600      ' USART1 baud rate
Declare Hrsout1_Pin = PORTB.14  ' Select the pin for TX with USART1

Declare Adin_Tad = cFRC          ' RC OSC chosen
Declare Adin_Delay = 10         ' Allow 10us sample time

Dim wRaw as Word
Dim fVolts as Double
Symbol Quanta = 3.3 / 1024      ' Calculate the quantising value for 10-bits

RPOR7 = 3                       ' Make PPS Pin RP14 U1TX
AD1CON2 = 0                     ' +Vref = AVdd, -Vref = AVss
AD1PCFGbits_PCFG0 = 0          ' Analogue input on AN0
While
    wRaw = Adin 0
    fVolts = wRaw * Quanta
    HrsoutLn Dec2 fVolts, "V"
    DelayMs 300
Wend
```

Notes.

Any expression that contains a floating point variable or constant will always be calculated as a floating point, even if the expression also contains integer constants or variables. The same applies for Doubles. If an expression has a mix of 32-bit floats and 64-bit doubles, then it will be carried out as 64-bit Double.

If the assignment variable is an integer variable, but the expression is of a floating point nature, then the floating point result will be converted into an integer.

```
Device = 24FJ64GA002
Declare Xtal = 16
Declare Hserial_Baud = 9600      ' USART1 baud rate
Declare Hrsout1_Pin = PORTB.14  ' Select the pin for TX with USART1

Dim MyDword as Dword
Dim MyFloat as Float
Symbol cPI = 3.14

RPOR7 = 3                        ' Make PPS Pin RP14 U1TX
MyFloat = 10
,
' Float calculation with result 13.14, reduced to integer 13
,
MyDword = MyFloat + cPI
HrsoutLn Dec MyDword            ' Display the integer result 13
```

Floating Point To Integer Rounding

Assigning a 32-bit or 64-bit floating point variable to an integer type will be truncated to the lowest value by default. For example:

```
MyFloat = 3.9
MyDword = MyFloat
```

The variable MyDword will hold the value of 3.

Floating Point Exception Flags

The floating point exception flags are accessible from within the BASIC program via the system variable `_FP_FLAGS`.

The exceptions are:

```
_FP_FLAGS.1      ' Floating point overflow
_FP_FLAGS.2      ' Floating point underflow
_FP_FLAGS.3      ' Floating point divide by zero
_FP_FLAGS.5      ' Domain error exception
```

The exception bits can be aliased for more readability within the program:

```
Symbol FpOverflow      = _FP_FLAGS.1  ' Floating point overflow
Symbol FpUnderFlow    = _FP_FLAGS.2  ' Floating point underflow
Symbol FpDiv0         = _FP_FLAGS.3  ' Floating point divide by zero
Symbol FpDomainError  = _FP_FLAGS.5  ' Domain error exception
```

After an exception is detected and handled in the program, the exception bit should be cleared so that new exceptions can be detected, however, exceptions can be ignored because new operations are not affected by old exceptions.

See also : [Dim](#), [Symbol](#), [Aliases](#), [Arrays](#).

Aliases

The **Symbol** directive is the primary method of creating an alias, however **Dim** can be used to create an alias to a variable. This is extremely useful for accessing the separate parts of a variable.

```
Dim Fido as Dog           ' Fido is another name for Dog
Dim Mouse as Rat.LowByte ' Mouse is the first byte (low byte) of word Rat
Dim Tail as Rat.HighByte ' Tail is the second byte(high byte) of word Rat
Dim Flea as Dog.0        ' Flea is bit-0 of Dog, which is aliased to Fido
```

There are modifiers that may also be used with variables. These are **HighByte**, **LowByte**, **Byte0**, **Byte1**, **Byte2**, **Byte3**, **Word0**, **Word1**, **HighSByte**, **LowSByte**, **SByte0**, **SByte1**, **SByte2**, **SByte3**, **SWord0**, and **SWord1**,

Word0, **Word1**, **Byte2**, **Byte3**, **SWord0**, **SWord1**, **SByte2**, and **SByte3** may only be used in conjunction with 32-bit **Dword** or **SDword** type variables.

HighByte and **Byte1** are one and the same thing, when used with a **Word** or **SWord** type variable, they refer to the unsigned High byte of a **Word** or **SWord** type variable: -

```
Dim MyWord as Word           ' Create an unsigned Word variable
Dim MyWord_Hi as MyWord.HighByte
' MyWord_Hi now represents the unsigned high byte of variable MyWord
```

Variable **MyWord_Hi** is now accessed as a **Byte** sized type, but any reference to it actually alters the high byte of **MyWord**.

HighSByte and **SByte1** are one and the same thing, when used with a **Word** or **SWord** type variable, they refer to the signed High byte of a **Word** or **SWord** type variable: -

```
Dim MyWord as SWord          ' Create a signed Word variable
Dim MyWord_Hi as MyWord.SByte1
' MyWord_Hi now represents the signed high byte of variable MyWord
```

Variable **MyWord_Hi** is now accessed as an **SByte** sized type, but any reference to it actually alters the high byte of **MyWord**.

However, if **Byte1** is used in conjunction with a **Dword** type variable, it will extract the second byte. **HighByte** will still extract the high byte of the variable, as will **Byte3**. If **SByte1** is used in conjunction with an **SDword** type variable, it will extract the signed second byte. **HighSByte** will still extract the signed high byte of the variable, as will **SByte3**.

The same is true of **LowByte**, **Byte0**, **LowSByte** and **SByte0**, but they refer to the unsigned or signed Low Byte of a **Word** or **SWord** type variable: -

```
Dim MyWord as Word           ' Create an unsigned Word variable
Dim MyWord_Lo as MyWord.LowByte
' MyWord_Lo now represents the low byte of variable MyWord
```

Variable **MyWord_Lo** is now accessed as a **Byte** sized type, but any reference to it actually alters the low byte of **MyWord**.

The modifier **Byte2** will extract the 3rd unsigned byte from a 32-bit **Dword** or **SDword** type variable as an alias. Likewise **Byte3** will extract the unsigned high byte of a 32-bit variable.

```
Dim Dwd as Dword      ' Create a 32-bit unsigned variable named Dwd
Dim Part1 as Dwd.Byte0 ' Alias unsigned Part1 to the low byte of Dwd
Dim Part2 as Dwd.Byte1 ' Alias unsigned Part2 to the 2nd byte of Dwd
Dim Part3 as Dwd.Byte2 ' Alias unsigned Part3 to the 3rd byte of Dwd
Dim Part4 as Dwd.Byte3 ' Alias unsigned Part3 to the high 4th byte of Dwd
```

The modifier **SByte2** will extract the 3rd signed byte from a 32-bit **Dword** or **SDword** type variable as an alias. Likewise **SByte3** will extract the signed high byte of a 32-bit variable.

```
Dim sDwd as SDword    ' Create a 32-bit signed variable named sDwd
Dim sPart1 as sDwd.SByte0 ' Alias signed Part1 to the low byte of sDwd
Dim sPart2 as sDwd.SByte1 ' Alias signed Part2 to the 2nd byte of sDwd
Dim sPart3 as sDwd.SByte2 ' Alias signed Part3 to the 3rd byte of sDwd
Dim sPart4 as sDwd.SByte3 ' Alias signed Part3 to the 4th byte of sDwd
```

The **Word0** and **Word1** modifiers extract the unsigned low word and high word of a **Dword** or **SDword** type variable, and is used the same as the **Byten** modifiers.

```
Dim Dwd as Dword      ' Create a 32-bit unsigned variable named Dwd
Dim Part1 as Dwd.Word0 ' Alias unsigned Part1 to the low word of Dwd
Dim Part2 as Dwd.Word1 ' Alias unsigned Part2 to the high word of Dwd
```

The **SWord0** and **SWord1** modifiers extract the signed low word and high word of a **Dword** or **SDword** type variable, and is used the same as the **SByten** modifiers.

```
Dim sDwd as SDword    ' Create a 32-bit signed variable named sDwd
Dim sPart1 as sDwd.SWord0 ' Alias Part1 to the low word of sDwd
Dim sPart2 as sDwd.SWord1 ' Alias Part2 to the high word of sDwd
```

Finer points of variable handling.

Word and **SWord** type variables have a low byte and a high byte. The high byte may be accessed by simply adding the letter H to the end of the variable's name. For example: -

```
Dim MyWord as Word
```

Will produce the assembler code: -

```
MyWord: .space 2
.def MyWord
.val MyWord
.scl 2
.size 2
.type 016
.undef
.set MyWordH, n
```

This is only really useful when assembler routines are being implemented, such as: -

```
Mov.b #1,W0
Mov.b WREG, MyWordH      ' Load the high byte of MyWord with 1
```

Dword, **SDWord** and **Float** type variables have a low, mid1, mid2, and high byte. The high byte may be accessed by using **Byte0**, **Byte1**, **Byte2**, or **Byte3**. For example: -

```
Dim MyDword as Dword
```

To access the high byte of variable MyDword, use: -

```
MyDword.Byte3 = 1
```

The same is true of all the alias modifiers such as **SWord0**, **Word0** etc...

Casting a variable from signed to unsigned and vice-versa is also possible using the modifiers. For example:

```
Dim sMyDword as SDword ' Create a 32-bit signed variable

sMyDword.Byte3 = 1      ' Load the unsigned high byte with the value 1
sMyDword.SByte0 = -1   ' Load the signed low byte with the value -1
sMyDword.SWord0 = 128  ' Load signed low and mid1 bytes with 128
```

Notes.

The final RAM usage will also encompass the microcontroller's stack size, therefore, even if the BASIC program only declares 4 **Byte** variables, the final RAM count will be 84. 80 bytes for the default stack size and 4 bytes for variable usage. If handled interrupts are used, the stack size will increase due to context saving and restoring requirements.

RAM locations for variables is allocated automatically within the microcontroller because the PIC24[®] and dsPIC33[®] range of devices have specific requirements concerning RAM addressing. Which are:

- 16-bit variables must be located on a 16-bit RAM address boundary.
- 32-bit and 64-bit variables must be placed on a 16-bit RAM address boundary, but should be placed on a 32-bit RAM address, if possible, for more efficiency with some mnemonics.
- 8-bit variables can be located on an 8-bit, 16-bit or 32-bit RAM address boundary.

Therefore, the order of variable placements is:

- The microcontroller's 16-bit stack is located before all variables are placed.
- The compiler's 16-bit system variables are placed.
- **Word** variables are placed.
- **Dword** variables are placed.
- **Float** variables are placed.
- **Double** variables are placed.
- **Byte** variables are placed.
- **Word Arrays** are placed.
- **Dword Arrays** are placed.
- **Float Arrays** are placed.
- **Byte Arrays** are placed.
- **String** variables are placed.

The logic behind the variable placements is because of the microcontroller's near and far RAM.

The first 8192 bytes of RAM are considered "near" RAM, while space above that is considered "far" RAM. By default, the compiler sets all user variables to near RAM. However, when near RAM space is full, the compiler will place variables in far RAM (above 8192).

The special significance of near versus far to the compiler is that near RAM accesses are encoded in only one mnemonic using direct addressing, while accesses to variables in far RAM require two to three mnemonics using indirect addressing.

Standard variables are used more commonly within a BASIC program, therefore should reside in near RAM for efficiency. Arrays and Strings are generally accessed indirectly anyway, therefore, it is usually of little consequence if they reside in near or far RAM.

The PIC24[®] and dsPIC33[®] range of devices have 16 WREG SFRs (Special Function Registers), each 16-bits wide. These are invaluable assets when the fastest possible speed is required by a program's routines or procedures. However, the compiler needs certain WREG SFRs for its own use, as does the microcontroller itself. Below is a rough list of the compiler's and microcontroller's WREG use.

- **WREG0**, **WREG1**, **WREG2** and **WREG3** are used internally by the compiler for its mathematical expressions, as well as comparisons. These WREGs should be considered as volatile and never used for storage of data for more than a brief length of time.
- **WREG6**, **WREG7** and **WREG8** are sometimes used as parameter storage for the compiler's commands.
- **WREG12** and **WREG13** are used for array indexing.
- **WREG14** is the microcontroller's Frame Pointer. As such, it must not be accessed directly unless the user is fully aware of the ramifications.
- **WREG15** is the microcontroller's Stack Pointer. As such, it must not be accessed directly unless the user is fully aware of the ramifications.

A WREG SFR can be used in a BASIC program just the same as any user defined variable. For example:

```
WREG0 = 12345
```

Note that the WREG SFRs are each 16-bits wide, but they can be sliced by the **.Byte0** and **.Byte1** directives, just as a user variable can be:

```
WREG0.Byte0 = 12  
WREG0.Byte1 = 34
```

Symbols

The **Symbol** directive provides a method for aliasing variables and/or constants. **Symbol** cannot be used to create a variable. Constants declared using **Symbol** do not use any RAM within the microcontroller.

```
Symbol cCat = 123
Symbol cTiger = cCat           ' cTiger now holds the value of cCat
Symbol cMouse = 1
Symbol cTigOuse = cTiger + cMouse ' Add cTiger to cMouse to make cTigOuse
```

Floating point constants may also be created using **Symbol** by simply adding a decimal point to a value.

```
Symbol PI = 3.14 ' Create a floating point constant named PI
Symbol FlNum = 5.0 ' Create a floating point constant holding the value 5
```

Floating point constant can also be created using expressions.

```
' Create a floating point constant holding the result of the expression
Symbol Quanta = 3.3 / 1024
```

If a variable or SFR's name is used in a constant expression then the variable's or SFR's address will be substituted, not the value held in the variable or SFR: -

```
Symbol MyCon = (PORTB + 1) ' MyCon will hold the value 715 (714+1)
```

Symbol is also useful for aliasing Ports and SFRs (Special Function Registers): -

```
Symbol LED = PORTA.1 ' LED now references bit-1 of PORTA
Symbol OSCFAIL = INTCON1.1 ' OSCFAIL now refers to bit-1 of INTCON1 SFR
```

Creating and using Arrays

The Proton24 compiler supports multi part **Byte**, **Word**, **Dword**, **SByte**, **SWord**, **SDword** and **Float** variable arrays. An array is a group of variables of the same size (8-bits, 16-bits or 32-bits wide), sharing a single name, but split into numbered cells, called elements.

An array is defined using the following syntax: -

```
Dim Name[length] as Byte
Dim Name[length] as Word
Dim Name[length] as Dword
Dim Name[length] as SByte
Dim Name[length] as SWord
Dim Name[length] as SDword
Dim Name[length] as Float
```

where *Name* is the variable's given name, and the new argument, [*length*], informs the compiler how many elements you want the array to contain. For example: -

```
Dim MyArray[10] as Byte      ' Create a 10 element unsigned byte array.
Dim MyArray[10] as Word     ' Create a 10 element unsigned word array.
Dim MyArray[10] as Dword    ' Create a 10 element unsigned dword array.
Dim sMyArray[10] as SByte   ' Create a 10 element signed byte array.
Dim sMyArray[10] as SWord   ' Create a 10 element signed word array.
Dim sMyArray[10] as SDword  ' Create a 10 element signed dword array.
Dim fMyArray[10] as Float   ' Create a 10 element floating point array.
```

Arrays may have up to 65535 elements.

Once an array is created, its elements may be accessed numerically. Numbering starts at 0 and ends at n-1. For example: -

```
MyArray[3] = 57
Hrsout "MyArray[3] = ", Dec MyArray[3], 13
```

The above example will access the fourth element in the **Byte** array and display "MyArray[3] = 57" on the serial terminal. The true flexibility of arrays is that the index value itself may be a variable. For example: -

```
Device = 24FJ64GA002
Declare Xtal = 16
Declare Hserial_Baud = 9600      ' USART1 baud rate
Declare Hrsout1_Pin = PORTB.14  ' Select the pin for TX with USART1

Dim MyArray[10] as Byte         ' Create a 10-byte array.
Dim Index as Byte              ' Create a Byte variable.

RPOR7 = 3                      ' Make PPS Pin RP14 U1TX
For Index = 0 to 9             ' Repeat with Index= 0,1,2...9
    MyArray[Index] = Index * 10 ' Write to each element of the array.
Next
For Index = 0 to 9             ' Repeat with Index= 0,1,2...9
    HrsoutLn Dec MyArray[Index] ' Show the contents of each element.
    DelayMs 500                 ' Wait long enough to view the values
Next
```

If the previous program is run, 10 values will be displayed, counting from 0 to 90 i.e. Index * 10.

A word of caution regarding arrays: If you're familiar with interpreted BASICs and have used their arrays, you may have run into the "subscript out of range" error. Subscript is simply another term for the index value. It is considered "out-of range" when it exceeds the maximum value for the size of the array.

For example, in the previous example, MyArray is a 10-element array. Allowable index values are 0 through 9. If your program exceeds this range, the compiler will not respond with an error message. Instead, it will access the next RAM location past the end of the array.

If you are not careful about this, it can cause all sorts of subtle anomalies, as previously loaded variables are overwritten. It's up to the programmer (you!) to prevent this from happening.

Even more flexibility is allowed with arrays because the index value may also be an expression.

```
Device = 24FJ64GA002
Declare Xtal = 16
Declare Hserial_Baud = 9600      ' USART1 baud rate
Declare Hrsout1_Pin = PORTB.14  ' Select the pin for TX with USART1

Dim MyArray[10] as Byte         ' Create a 10-byte array.
Dim Index as Byte               ' Create a Byte variable.
RPOR7 = 3                       ' Make PPS Pin RP14 U1TX
For Index = 0 to 8              ' Repeat with Index= 0,1,2...8
    MyArray[Index + 1] = Index * 10 ' Write to each element of array
Next
For Index = 0 to 8              ' Repeat with Index= 0,1,2...8
    Hrsout Dec MyArray[Index + 1], 13 ' Show the contents of elements
    DelayMs 500                 ' Wait long enough to view the values
Next
```

The expression within the square braces should be kept simple, and arrays are not allowed as part of the expression.

Using Arrays in Expressions.

Of course, arrays are allowed within expressions themselves. For example: -

```
Dim MyArray[10] as Byte ' Create a 10-byte array.
Dim Index as Byte      ' Create a Byte variable.
Dim MyByte as Byte     ' Create another Byte variable
Dim MyResult as Byte   ' Create a variable to hold result of expression
Index = 5               ' And Index now holds the value 5
MyByte = 10            ' Variable MyByte now holds the value 10
MyArray[Index] = 20    ' Load the 6th element of MyArray with value 20
MyResult = (MyByte * MyArray[Index]) / 20 ' Do a simple expression
Hrsout Dec MyResult, 13 ' Display result of expression
```

The previous example will display 10 on the LCD, because the expression reads as: -

$$(10 * 20) / 20$$

MyByte holds a value of 10, MyArray[Index] holds a value of 20, these two variables are multiplied together which will yield 200, then they're divided by the constant 20 to produce a result of 10.

Byte Arrays as Strings

Byte arrays may also be used as simple strings in certain commands, because after all, a string is simply a byte array used to store text.

For this, the **Str** modifier is used.

Some of the commands that support the **Str** modifier are: -

Busout - Busin
Hbusout - Hbusin
Hrsout - Hrsin
Owrite - Oread
Rsout - Rsin
Serout - Serin
Shout - Shin
Print

The **Str** modifier works in two ways, it outputs data from a pre-declared array in commands that send data i.e. **Rsout**, **Print** etc, and loads data into an array, in commands that input information i.e. **Rsin**, **Serin** etc. The following examples illustrate the **Str** modifier in each compatible command.

Using **Str** with the **Busin** and **Busout** commands.

Refer to the sections explaining the **Busin** and **Busout** commands.

Using **Str** with the **Hbusin** and **Hbusout** commands.

Refer to the sections explaining the **Hbusin** and **Hbusout** commands.

Using **Str** with the **Rsin** command.

```
Dim Array1[10] as Byte      ' Create a 10-byte array named Array1
Rsin Str Array1            ' Load 10 bytes of data directly into Array1
```

Using **Str** with the **Rsout** command.

```
Dim Array1[10] as Byte      ' Create a 10-byte array named Array1
Rsout Str Array1           ' Send 10 bytes of data directly from Array1
```

Using **Str** with the **Hrsin** and **Hrsout** commands.

Refer to the sections explaining the **Hrsout** and **Hrsin** commands.

Using **Str** with the **Shout** command.

```
Symbol DTA = PORTA.0      ' Alias the two lines for the Shout command
Symbol CLK = PORTA.1
Dim Array1[10] as Byte    ' Create a 10-byte array named Array1
' Send 10 bytes of data from Array1
Shout DTA, CLK, MsbFirst, [Str Array1]
```

Using **Str** with the **Shin** command.

```
Symbol DTA = PORTA.0      ' Alias the two lines for the Shin command
Symbol CLK = PORTA.1
Dim Array1[10] as Byte    ' Create a 10-byte array named Array1
' Load 10 bytes of data directly into Array1
Shin DTA, CLK, MsbPre, [Str Array1]
```

Using **Str** with the **Print** command.

```
Dim Array1[10] as Byte    ' Create a 10-byte array named Array1
Print Str Array1          ' Send 10 bytes of data directly from Array1
```

Using **Str** with the **Serout** and **Serin** commands.

Refer to the sections explaining the **Serin** and **Serout** commands.

Using **Str** with the **Oread** and **Owrite** commands.

Refer to the sections explaining the **Oread** and **Owrite** commands.

The **Str** modifier has two forms for variable-width and fixed-width data, shown below: -

Str ByteArray ASCII string from ByteArray until byte = 0 (null terminated).

Or array length is reached.

Str ByteArray\n ASCII string consisting of n bytes from ByteArray.

Null terminated means that a zero (null) is placed at the end of the string of ASCII characters to signal that the string has finished.

The example below is the variable-width form of the **Str** modifier: -

```
Dim MyArray[5] as Byte    ' Create a 5 element array
MyArray[0] = "A"          ' Fill the array with ASCII
MyArray[1] = "B"
MyArray[2] = "C"
MyArray[3] = "D"
MyArray[4] = 0            ' Add the null Terminator
Print Str MyArray         ' Display the string
```

The code above displays "ABCD" on the LCD. In this form, the **Str** formatter displays each character contained in the byte array until it finds a character that is equal to 0 (value 0, not ASCII "0"). Note: If the byte array does not end with 0 (null), the compiler will read and

output all RAM register contents until it cycles through all RAM locations for the declared length of the byte array.

For example, the same code as before without a null terminator is: -

```
Dim MyArray[4] as Byte      ' Create a 4 element array
MyArray[0] = "A"           ' Fill the array with ASCII
MyArray[1] = "B"
MyArray[2] = "C"
MyArray[3] = "D"
Print Str MyArray          ' Display the string
```

The code above will display the whole of the array, because the array was declared with only four elements, and each element was filled with an ASCII character i.e. "ABCD".

To specify a fixed-width format for the **Str** modifier, use the form **Str MyArray\n**; where MyArray is the byte array and n is the number of characters to display, or transmit. Changing the **Print** line in the examples above to: -

```
Print Str MyArray \ 2
```

would display "AB" on the LCD.

Str is not only used as a modifier, it is also a command, and is used for initially filling an array with data. The above examples may be re-written as: -

```
Dim MyArray[5] as Byte      ' Create a 5 element array
Str MyArray = "ABCD", 0     ' Fill array with ASCII, and null terminate it
Print Str MyArray          ' Display the string
```

Strings may also be copied into other strings: -

```
Dim String1[5] as Byte      ' Create a 5 element array
Dim String2[5] as Byte      ' Create another 5 element array
Str String1 = "ABCD", 0     ' Fill array with ASCII, and null terminate it
Str String2 = "EFGH", 0     ' Fill other array with ASCII, null terminate it
Str String1 = Str String2   ' Copy String2 into String1
Print Str String1          ' Display the string
```

The above example will display "EFGH", because String1 has been overwritten by String2.

Using the **Str** command with **Busout**, **Hbusout**, **Shout**, and **Owrite** differs from using it with commands **Serout**, **Print**, **Hrsout**, and **Rsout** in that, the latter commands are used more for dealing with text, or ASCII data, therefore these are null terminated.

The **Hbusout**, **Busout**, **Shout**, and **Owrite** commands are not commonly used for sending ASCII data, and are more inclined to send standard 8-bit bytes. Thus, a null terminator would cut short a string of byte data, if one of the values happened to be a 0. So these commands will output data until the length of the array is reached, or a fixed length terminator is used i.e. MyArray\n.

Finer points of array variables.

When an array is created, the compiler creates each of its elements as an independent variable that has the same width and sign as the parent array. For example:

```
Dim MyByteArray[10] as Byte
```

Will also produce 10 separate variables named:

```
MyByteArray_0  
MyByteArray_1  
MyByteArray_2  
MyByteArray_3  
MyByteArray_4  
MyByteArray_5  
MyByteArray_6  
MyByteArray_7  
MyByteArray_8  
MyByteArray_9
```

Notice the underscore after the name of the array, and preceding the element's positional value within the array. Each of these elements is an unsigned **Byte** variable in its own right, and can be accessed collectively or independently. The same principle applies to all array types supported by the compiler.

Note that this differs from Proton for 8-bit devices in that the separation between the array name and the element number is a hash '#' in Proton 8-bit, but this is not allowed in the 16-bit assembler, therefore, they are underscores in Proton24.

Block Array Assigning

One array can be loaded into another array by issuing the names of the arrays but without the square brackets. For example:

```
Dim SourceArray[10] as Byte = 1,2,3,4,5,6,7,8,9,10  
Dim DestArray[10] as Byte
```

```
DestArray = SourceArray ' Copy the contents of SourceArray into DestArray
```

If different type arrays are used as the assignment or the source, truncation or extrapolation will take place. If the assignment array has fewer elements than the source array, only the elements that will fit into the assignment array will be copied.

Creating and using String variables

A string variable is essentially a byte array that is terminated by a null (represented by 0). A string is intended to hold only ASCII characters.

The syntax to create a string is : -

```
Dim String Name as String * String Length
```

String Name can be any valid variable name. See **Dim** .

String Length can be any value up to 8192, allowing up to 8192 characters to be stored.

The line of code below will create a **String** named ST that can hold 20 characters: -

```
Dim MyString as String * 20
```

Two or more strings can be concatenated (linked together) by using the plus (+) operator: -

```
Device = 24FJ64GA002
Declare Xtal = 16
'
' Create three strings capable of holding 20 characters
'
Dim DestString as String * 20
Dim SourceString1 as String * 20
Dim SourceString2 as String * 20

SourceString1 = "Hello " ' Load String SourceString1 with the text Hello
' Load String SourceString2 with the text World
SourceString2 = "World"
' Add both Source Strings together. Place result into String DestString
DestString = SourceString1 + SourceString2
```

The String DestString now contains the text "Hello World".

The Destination String itself can be added to if it is placed as one of the variables in the addition expression. For example, the above code could be written as: -

```
Device = 24FJ64GA002
Declare Xtal = 16

Dim DestString as String * 20 ' Create a String for 20 characters
Dim SourceString as String * 20 ' Create another String for 20 characters

DestString = "Hello " ' Pre-load String DestString with the text Hello
SourceString = "World" ' Load String SourceString with the text World
' Concatenate DestString with SourceString
DestString = DestString + SourceString
Print DestString ' Display the result which is "Hello World"
```

Note that Strings cannot be subtracted, multiplied or divided, and cannot be used as part of a standard expression otherwise a syntax error will be produced.

It's not only other strings that can be added to a string, the functions **Cstr**, **Estr**, **Mid\$**, **Left\$**, **Right\$**, **Str\$**, **ToUpper**, and **ToLower** can also be used as one of variables to concatenate.

A few examples of using these functions are shown below: -

Cstr Example

```
' Use Cstr function to place a code memory string into a RAM String variable

Device 24FJ64GA002
Declare Xtal = 16

Dim DestString as String * 20      ' Create a String for 20 characters
Dim SourceString as String * 20    ' Create another String
Dim CodeStr as Code = "World",0

SourceString = "Hello "           ' Load the string with characters
DestString = SourceString + Cstr CodeStr ' Concatenate the string
Print DestString                  ' Display the result which is "Hello World"
```

The above example is really only for demonstration because if a Label name is placed as one of the parameters in a string concatenation, an automatic (more efficient) **Cstr** operation will be carried out. Therefore the above example should be written as: -

More efficient Example of above code

```
' Place a code memory string into a String variable more efficiently than
' using Cstr

Device 24FJ64GA002
Declare Xtal = 16

Dim DestString as String * 20      ' Create a String for 20 characters
Dim SourceString as String * 20    ' Create another String
Dim CodeStr as Code = "World",0

SourceString = "Hello "           ' Load the string with characters
DestString = SourceString + CodeStr ' Concatenate the string
Print DestString                  ' Display the result which is "Hello World"
```

A null terminated string of characters held in Data (on-board eeprom) memory can also be loaded or concatenated to a string by using the **Estr** function: -

Estr Example

```
' Use the Estr function in order to place a
' Data memory string into a String variable
' Remember to place Edata before the main code
' so it is recognised as a constant value

Device 24F08KL200           ' Choose a device with on-board eeprom
Declare Xtal = 16

Dim DestString as String * 20      ' Create a String for 20 characters
Dim SourceString as String * 20    ' Create another String
Data_Str Edata "World",0          ' Create a string in Data memory

SourceString = "Hello "           ' Load the string with characters
DestString = SourceString + Estr Data_Str ' Concatenate the strings
Print DestString                  ' Display the result which is "Hello World"
```

Converting an integer or floating point value into a string is accomplished by using the **Str\$** function: -

Str\$ Example

```
' Use the Str$ function in order to concatenate
'an integer value into a String variable
Device 24FJ64GA002
Declare Xtal = 16
Dim DestString as String * 30 ' Create a String
Dim SourceString as String * 20 ' Create another String
Dim MyWord as Word ' Create a Word variable

MyWord = 1234 ' Load the Word variable with a value
SourceString = "Value = " ' Load the string with characters
DestString = SourceString + Str$(Dec MyWord) ' Concatenate the string
Print DestString ' Display the result which is "Value = 1234"
```

Left\$ Example

```
' Copy 5 characters from the left of SourceString
' and add to a quoted character string
Device 24FJ64GA002
Declare Xtal = 16
Dim SourceString as String * 20 ' Create a String
Dim DestString as String * 20 ' Create another String

SourceString = "Hello World" ' Load the source string with characters
DestString = Left$(SourceString, 5) + " World"
Print DestString ' Display the result which is "Hello World"
```

Right\$ Example

```
' Copy 5 characters from the right of SourceString
' and add to a quoted character string
Device 24FJ64GA002
Declare Xtal = 16
Dim SourceString as String * 20 ' Create a String
Dim DestString as String * 20 ' Create another String

SourceString = "Hello World" ' Load the source string with characters
DestString = "Hello " + Right$(SourceString, 5)
Print DestString ' Display the result which is "Hello World"
```

Mid\$ Example

```
' Copy 5 characters from position 4 of SourceString
' and add to quoted character strings
Device 24FJ64GA002
Declare Xtal = 16
Dim SourceString as String * 20 ' Create a String
Dim DestString as String * 20 ' Create another String

SourceString = "Hello World" ' Load the source string with characters
DestString = "Hel" + Mid$(SourceString, 4, 5) + "rld"
Print DestString ' Display the result which is "Hello World"
```

Converting a string into uppercase or lowercase is accomplished by the functions **ToUpper** and **ToLower**: -

ToUpper Example

```
' Convert the characters in SourceString to upper case
```

```
Device 24FJ64GA002
Declare Xtal = 16
Dim SourceString as String * 20 ' Create a String
Dim DestString as String * 20   ' Create another String

SourceString = "hello world"    ' Load source with lowercase characters
DestString = ToUpper(SourceString)
Print DestString                ' Display the result which is "HELLO WORLD"
```

ToLower Example

```
' Convert the characters in SourceString to lower case
```

```
Device 24FJ64GA002
Declare Xtal = 16
Dim SourceString as String * 20 ' Create a String
Dim DestString as String * 20   ' Create another String

SourceString = "HELLO WORLD"    ' Load the string with uppercase characters
DestString = ToLower(SourceString)
Print DestString                ' Display the result which is "hello world"
```

Loading a String Indirectly

If the Source String is a signed or unsigned **Byte**, **Word**, **Float** or an **Array** variable, the value contained within the variable is used as a pointer to the start of the Source String's address in RAM.

Example

```
' Copy SourceString into DestString using a pointer to SourceString
```

```
Device 24FJ64GA002
Declare Xtal = 16
Dim SourceString as String * 20 ' Create a String
Dim DestString as String * 20   ' Create another String
,
' Create a Word variable to hold the address of SourceString
,
Dim StringAddr as Word

SourceString = "Hello World"    ' Load the source string with characters
,
' Locate the start address of SourceString in RAM
,
StringAddr = AddressOf(SourceString)
DestString = StringAddr        ' Source string into the destination string
Print DestString                ' Display the result, which will be "Hello"
```

Slicing a String.

Each position within the string can be accessed the same as an unsigned **Byte Array** by using square braces: -

```
Device 24FJ64GA002
Declare xtal = 16
Dim SourceString as String * 20 ' Create a String

SourceString[0] = "H" ' Place letter "H" as first character
SourceString[1] = "e" ' Place the letter "e" as the second character
SourceString[2] = "l" ' Place the letter "l" as the third character
SourceString[3] = "l" ' Place the letter "l" as the fourth character
SourceString[4] = "o" ' Place the letter "o" as the fifth character
SourceString[5] = 0 ' Add a null to terminate the string

Print SourceString ' Display the string, which will be "Hello"
```

The example above demonstrates the ability to place individual characters anywhere in the string. Of course, you wouldn't use the code above in an actual BASIC program.

A string can also be read character by character by using the same method as shown above: -

```
Device 24FJ64GA002
Declare xtal = 16
Dim SourceString as String * 20 ' Create a String
Dim Var1 as Byte

SourceString = "Hello" ' Load the source string with characters
' Copy character 1 from the source string and place it into Var1
Var1 = SourceString[1]
Print Var1 ' Display character extracted from string. Which will be "e"
```

When using the above method of reading and writing to a string variable, the first character in the string is referenced at 0 onwards, just like an unsigned **Byte Array**.

The example below shows a more practical String slicing demonstration.

```
' Display a string's text by examining each character individually
Device 24FJ64GA002
Declare xtal = 16
Dim SourceString as String * 20 ' Create a String
Dim Charpos as Byte ' Holds the position within the string

SourceString = "Hello World" ' Load the source string with characters
Charpos = 0 ' Start at position 0 within the string
Repeat ' Create a loop
' Display the character extracted from the string
Print SourceString[Charpos]
Inc Charpos ' Move to the next position within the string
' Keep looping until the end of the string is found
Until Charpos = Len(SourceString)
```

Notes.

A word of caution regarding Strings: If you're familiar with interpreted BASICs and have used their String variables, you may have run into the "subscript out of range" error. This error occurs when the amount of characters placed in the string exceeds its maximum size.

For example, in the examples above, most of the strings are capable of holding 20 characters. If your program exceeds this range by trying to place 21 characters into a string only created for 20 characters, the compiler will not respond with an error message. Instead, it will access the next RAM location past the end of the String.

If you are not careful about this, it can cause all sorts of subtle anomalies as previously loaded variables are overwritten. It's up to the programmer (you!) to prevent this from happening by ensuring that the **String** in question is large enough to accommodate all the characters required, but not too large that it uses up too much precious RAM.

The compiler will help by giving a reminder message when appropriate, but this can be ignored if you are confident that the **String** is large enough.

See also : **Creating and using code memory strings,**
 Creating and using code memory strings,
 Len, Left\$, Mid\$, Right\$
 String Comparisons, Str\$, ToLower, ToUpper, AddressOf.

Procedures

A procedure is essentially a subroutine in a wrapper that can be optionally passed parameter variables and optionally return a variable. The code within the procedure block is self contained, including local variables, symbols and labels whose names are local to the procedure's block and cannot be accessed by the main program or another procedure, even though the names may be the same within different procedures.

The Proton24 compiler has a rudimentary procedure mechanism that allows procedures to be constructed along with their local variables and, moreover, the procedure will not be included into the program unless it is called by the main program or from within another procedure. A procedure also has the ability to return a variable for use within an expression or comparison etc. This means that libraries of procedures can be created and only the ones called will actually be used.

A procedure is created by the keyword **Proc** and ended by the keyword **EndProc**

A simple procedure block is shown below:

```
Proc MyProc(pBytein as Byte)
  HrsoutLn Dec pBytein
EndProc
```

To use the above procedure, give its name and any associated parameters:

```
MyProc(123)
```

Parameters

A procedure may have up to 10 parameters. Each parameter must be given a unique name and a variable type. The parameter name must consist of more than one character. The types supported as parameters are:

Bit, Byte, SByte, Word, SWord, Dword, SDword, Float, Double, and String.

A parameter can be passed by value or by reference. By value will copy the contents into the parameter variable, while by reference will copy the address of the original variable into the parameter variable. By default, a parameter is passed by value. In order to pass a parameter by reference, so that it can be accessed by one of the **PtrX** commands, the parameter name must be preceded by the text **ByRef**. For clarification, the text **ByValue** may precede a parameter name to illustrate that the variable is passed by value. For example:

```
Proc MyProc(ByRef pWordin as Word, ByVal pDwordin as Dword)
  HrsoutLn Dec pWordin, " : ", Dec pDwordin
EndProc
```

The syntax for creating parameters is the same as when they are created using **Dim**. String or Array variables must be given lengths. For example, to create a 10 character **String** parameter use:

```
Proc MyProc(pMyString as String * 10)
```

To create a 10 element unsigned **Word** array parameter, use:

```
Proc MyProc(pMyArray[10] as Word)
```

A parameter can also be aliased to an SFR (Special Function Register). For example:

```
Proc MyProc(pMyWord as WREG0)
```

As with standard variables, the aliased parameter can also be casted to a type that has fewer bytes. For example, a **Word** variable can be casted to a **Byte** type, or a **Dword** can be casted to a **Word** or **Byte** type etc...

```
Proc MyProc(pMyByte as WREG2.Byte0)
```

Local Variable and Label Names

Any label, constant or variable created within a procedure is local to that procedure only. Meaning that it is only visible within the procedure, even if the name is the same as other variables created in other procedures, or global constants or variables. A local variable is created exactly the same as global variables. i.e. using **Dim**:

```
Proc MyProc(pMyByte as Byte)
  Dim MyLocal as Byte      ' Create a local byte variable
  MyLocal = pMyByte       ' Load the local variable with parameter variable
EndProc
```

Note that a local variable's name must consist of more than 1 character.

Return Variable

A procedure can return a variable of any type, making it useful for inclusion within expressions. The variable type to return is added to the end of the procedure's template. For example:

```
Proc MyProc(), SByte
  Result = 10
EndProc
```

All variable types are allowed as return parameters and follow the same syntax rules as **Dim**. Note that a return name is not required, only a type. For example:

```
Proc MyProc(), [12] as Byte      ' Procedure returns a 12 element byte array
Proc MyProc(), [12] as Word     ' Procedure returns a 12 element word array
Proc MyProc(), [12] as Dword   ' Procedure returns a 12 element dword array
Proc MyProc(), [12] as Float   ' Procedure returns a 12 element float array
Proc MyProc(), String * 12     ' Procedure returns a 12 character string
```

In order to return a value, the text "**Result**" is used. Internally, the text **Result** will be mapped to the procedure's return variable. For example:

```
Proc MyProc(pBytein as Byte), Byte
  Result = pBytein ' Transfer the parameter directly to the return variable
EndProc
```

The **Result** variable is mapped internally to a variable of the type given as the return parameter, therefore it is possible to use it the same as any other local variable, and upon return from the procedure, its value will be passed. For example:

```
Proc MyProc(pBytein as Byte), Byte
  Result = pBytein      ' Transfer the parameter to the return variable
  Result = Result + 1   ' Add one to it
EndProc
```

Returning early from a procedure is the same as returning from a subroutine. i.e. using the **Return** keyword.

```
Proc MyProc(pBytein as Byte), Byte
    Result = pBytein          ' Transfer the parameter to the return variable
    If pBytein = 0 Then Return ' Perform a test and return early if required
    Result = Result + 1       ' Otherwise... Add one to it
EndProc
```

A return parameter can also be aliased to an SFR (Special Function Register). For example:

```
Proc MyProc(), WREG0
```

As with standard variables, the aliased return parameter can also be casted to a type that has fewer bytes. For example, a **Word** variable can be casted to a **Byte** type, or a **Dword** can be casted to a **Word** or **Byte** type etc...

```
Proc MyProc(), WREG2.Byte0
```

Below is an example procedure that mimics the compiler's 16-bit **Dig** command.

```
Device = 24EP128MC202
Declare Xtal = 140.03
Declare Hserial_Baud = 9600          ' UART1 baud rate
Declare Hrsout1_Pin = PORTB.11      ' Select pin to be used for USART1 TX

Dim MyWord As Word = 12345
'-----
' Emulate the 16-bit Dig command's operation
' Input      : pWordin holds the value to extract from
'            : pDigit holds which digit to extract (1 To 5)
' Output     : Result holds the extracted value
' Notes     : None
'
Proc DoDig16(pWordin As Word, pDigit As Byte), Byte
Dim DigitLoop As Byte

pWordin = Abs(pWordin)
If pDigit > 0 Then
    For DigitLoop = (pDigit - 1) To 0 Step -1
        pWordin = pWordin / 10
    Next
EndIf
Result = pWordin // 10
EndProc
'-----
Main:
' Setup the Oscillator to operate the device at 140.03MHz
' Fosc = (7.37 * 76) / (2 * 2) = 140.03MHz
PLL_Setup(76, 2, 2, $0300)
RPOR4.Byte1 = 1          ' Make PPS Pin RB11 U1TX

HRSOut Dec DoDig16(MyWord, 0)
HRSOut Dec DoDig16(MyWord, 1)
HRSOut Dec DoDig16(MyWord, 2)
HRSOut Dec DoDig16(MyWord, 3)
HRSOutLn Dec DoDig16(MyWord, 4)
```

```
-----  
' Configure for internal 7.37MHz oscillator with PLL  
' OSC pins are general purpose I/O  
,  
    Config FGS = GWRP_OFF, GCP_OFF  
    Config FOSCSEL = FNOSC_FRCPLL, IESO_ON, PWMLOCK_OFF  
    Config FOSC = POSCMD_NONE, OSCIOFNC_ON, IOL1WAY_OFF, FCKSM_CSDCMD  
    Config FWDT = WDTPR_PS256, WINDIS_OFF, PLLKEN_ON, FWDTEN_OFF  
    Config FPOR = ALTI2C1_ON, ALTI2C2_OFF  
    Config FICD = ICS_PGD1, JTAGEN_OFF
```

Notes

The compiler's implementation of procedures is not as thorough as a true procedural language such as C or Pascal because they have had to be added to an already flat language. However, they are still a powerful feature of the language when used appropriately. Procedures are not supported in every instance of the compiler and if one is not supported within a particular command, a syntax error will be produced. In which case, an intermediate variable will need to be created to hold the procedure's return result:

```
MyTemp = MyProc()
```

The compiler does not re-cycle RAM for parameters or local variables.

A parameter that is passed **ByRef** can only ever be a **Byte**, **Word** or **Dword** type, because it will hold the address of the variable passed to it and not its value. This is then used by either **Ptr8**, **Ptr16**, **Ptr32** and **Ptr64** in order to manipulate the address indirectly. An example of this mechanism is shown below:

```
' Demonstrate a procedure for finding the length of a word array  
' given a particular terminator value  
,  
    Device = 24FJ64GA002  
    Declare Xtal = 16  
,  
' USART1 declares  
,  
    Declare Hserial_Baud = 9600      ' USART1 baud rate  
    Declare Hrsout1_Pin = PORTB.14  ' Select the pin for TX with USART1  
  
    Dim MyLength As Word  
    Dim MyArray[20] As Word = 1,2,3,4,5,6,7,8,9,10,11,12,13,14,15,16,17,0
```

```
-----  
' Find the length of a word array with a user defined terminator  
' Input      : pArrayIn holds the address of the word array  
'           : pTerminator holds the terminator value  
' Output     : Returns the length of the word array upto the terminator  
' Notes      : Uses indirect addressing using ByRef and Ptr16  
,  
Proc LengthOf(ByRef pInAddress As Word, pTerminator As Word), Word  
    Result = 0      ' Clear the result of the procedure  
    While           ' Create an infinite loop  
    ,  
    ' Increment up the array and exit the loop when the terminator is found  
    ,  
    If Ptr16(pInAddress++) = pTerminator Then Break
```

```
    Inc Result          ' Increment the count
  Wend
EndProc
-----
Main:
  RPOR7 = 3            ' Make PPS Pin RP14 U1TX
,
' Find the length of a null terminated word array
,
  MyLength = LengthOf(MyArray, 0)
  HRSOutLn Dec MyLength    ' Display the result on a serial terminal
```

See Also: [Ptr8](#), [Ptr16](#), [Ptr32](#), [Ptr64](#)

A Typical Flat BASIC Program Layout

The compiler is very flexible, and will allow most types of constant, declaration, or variable to be placed anywhere within the BASIC program. However, it may not produce the correct results, or an unexpected syntax error may occur due to a variable or declare being created after it is supposed to be used.

The recommended layout for a program is shown below.

```
Device                                ' Always required
,
Xtal declare                          ' Always required
,
General declares
,
Includes
,
Constants and/or Variables
,
GoTo Main                             ' Jump over the subroutines (if any)
,
Subroutines go here
,
Main:
  Main Program code goes here
```

For example:

```
Device = 24FJ64GA002
-----
Declare Xtal = 32
Declare Hserial_Baud = 9600
-----
' Load an include file (if required)
Include "MyInclude.inc"
-----
' Create Variables
Dim MyWord as Word                    ' Create a Word size variable
-----
' Define Constants and/or aliases
Symbol MyConst = 10                  ' Create a constant
-----
GoTo Main                             ' Jump over the subroutine/s (if any)
-----
' Simple Subroutine
AddIt:
  MyWord = MyWord + MyConst          ' Add the constant to the variable
  Return                              ' Return from the subroutine
-----
' Main Program Code
Main:
  RPOR7 = 3                          ' Make PPS Pin RP14 U1TX
  MyWord = 10                         ' Pre-load the variable
  GoSub AddIt                          ' Call the subroutine
  HrsoutLn Dec MyWord                 ' Display the result on the serial terminal
```

Of course, it depends on what is within the include file as to where it should be placed within the program, but the above outline will usually suffice. Any include file that requires placing within a certain position within the code should be documented to state this fact.

A Typical Procedural BASIC Program Layout

The compiler is very flexible, and will allow most types of constant, declaration, or variable to be placed anywhere within the BASIC program. However, it may not produce the correct results, or an unexpected syntax error may occur due to a variable or declare being created after it is supposed to be used.

The recommended layout for a program is shown below.

```
Device                                ' Always required
,
Xtal declare                          ' Always required
,
General declares
,
Includes
,
Constants and/or Variables
,
Procedures go here
,
Main:
Main Program code goes here
```

For example:

```
Device = 24FJ64GA002
-----
Declare Xtal = 32
Declare Hserial_Baud = 9600
-----
' Load an include file (if required)
Include "MyInclude.inc"
-----
' Create Variables
Dim MyWord as Word                    ' Create a Word size variable
-----
' Define Constants and/or aliases
Symbol MyConst = 10                  ' Create a constant
-----
' Simple Procedure
Proc AddIt(pMyWord1 as Word, pMyWord2 as Word), Word
Result = pMyWord1 + pMyWord2        ' Add the two variables as the result
EndProc
-----
' Main Program Code
Main:
RPOR7 = 3                            ' Make PPS Pin RP14 U1TX
MyWord = 10                          ' Pre-load the variable
MyWord = AddIt(MyWord, MyConst)      ' Call the procedure
HrsoutLn Dec MyWord                  ' Display the result on the serial terminal
```

Of course, it depends on what is within the include file as to where it should be placed within the program, but the above outline will usually suffice. Any include file that requires placing within a certain position within the code should be documented to state this fact.

General Format

The compiler is not case sensitive, except when processing string constants such as "hello".

Multiple instructions and labels can be combined on the same line by separating them with colons ':':

The examples below show the same program as separate lines and as a single-line: -

Multiple-line version: -

```
Low PORTB           ' Make all pins on PORTB outputs
For MyByte = 0 to 100 ' Count from 0 to 100
  PORTB = MyByte    ' Make PORTB = MyByte
Next                ' Continue counting until 100 is reached
```

Single-line version: -

```
Low PORTB: For MyByte = 0 to 100 : PORTB = MyByte: Next
```

Line Continuation Character '_'

Lines that are too long to display. i.e. greater than 1000 characters, may be split using the continuation character '_'. This will direct the continuation of a command to the next line. Its use is only permitted after a comma delimiter: -

```
Var1 = LookUp Var2,[1,2,3,_,
                    4,5,6,7,8]
```

OR

```
Print At 1,1,_,_
"Hello World",_
Dec Var1,_,_
Hex Var2
```

Creating and using Code Memory Tables

All 24-bit core devices have the ability to read their own flash memory. And although writing to this memory too many times is unhealthy for the device, reading this memory is both fast, and harmless. Which offers a form of data storage and retrieval, the **Dim as Code** directive proves this, as it uses the mechanism of reading and storing in the microcontroller's flash memory.

```
Dim MyCode as Code = As Dword 1, 2, 3, 4, 5
```

or

```
Dim MyCode as PSV = As Word 100, 200, 300, 400
```

Both of the above lines of code will create a data table in the device's code memory, however, the **PSV** directive will ensure that the **AddressOf** function returns the PSV address of the table, instead of its actual code memory address. This is used mainly for DSP operations.

The data produced by the **Code** or **PSV** directives follows the same casting rules as the **Cdata** directive, in that the table's data can be given a size that each element will occupy.

```
Dim CodeString As Code = "Hello World", 0
```

The above line will create, in code memory, the values that make up the ASCII text "Hello World", at address CodeString. Note the null terminator after the ASCII text.

To display, or transmit this string of characters, the following command structure could be used:

```
Hrsout CodeString
```

The label that declared the address where the list of code memory values resided now becomes the string's name.

Note the null terminators after the ASCII text in the table data. Without these, the microcontroller will continue to transmit data until it reaches a 0 value within code.

The term 'virtual string' relates to the fact that a string formed in code memory cannot (rather should not) be written too, but only read from.

Using the **Cstr** modifier it is also possible to use constants, variables and expressions that hold the address of the code memory data (a pointer). For example, the program below uses a **Word** size variable to hold 2 pointers (address of a label, variable, or array) to 2 individual null terminated text strings formed in code memory.

Example

```
Device 24FJ64GA002
Declare Xtal = 16

Dim Address as Word           ' Address holding variable
,
' Create the text to display
,
Dim CodeString1 as Code = "Hello ", 0
Dim CodeString2 as Code = "World", 0

DelayMs 100                   ' Wait for things to stabilise
Cls                            ' Clear the LCD

Address = AddressOf(CodeString1) ' Point address to CodeString1
Print Cstr Address             ' Display CodeString1
Address = AddressOf(CodeString2) ' Point Address to CodeString2
Print Cstr Address             ' Display CodeString2
```

String Comparisons

Just like any other variable type, **String** variables can be used within comparisons such as **If-Then**, **Repeat-Until**, and **While-Wend**. In fact, it's an essential element of any programming language.

Equal (=) or Not Equal (<>) comparisons are the only type that apply to Strings, because one **String** can only ever be equal or not equal to another **String**. It would be unusual (unless your using the C language) to compare if one **String** was greater or less than another.

So a valid comparison could look something like the lines of code below: -

```
If String1 = String2 Then
  Hrsout "Equal\r"
Else
  Hrsout "Not Equal\r"
EndIf
```

But as you've found out if you read the *Creating Strings* section, there is more than one type of **String** in a PIC24[®] and dsPIC33[®] microcontroller. There is a RAM **String** variable, a code memory string, and a quoted character string.

Note that pointers to **String** variables are not allowed in comparisons, and a syntax error will be produced if attempted.

Starting with the simplest of string comparisons, where one string variable is compared to another string variable. The line of code would look similar to either of the two lines above.

Example 1

```
' Simple string variable comparison
Device = 24FJ64GA002
Declare Xtal = 16

Dim String1 as String * 20      ' Create a String
Dim String2 as String * 20      ' Create another String

Cls
String1 = "EGGS"                ' Pre-load String String1 with the text EGGS
String2 = "BACON"               ' Load String String2 with the text BACON

If String1 = String2 Then       ' Is String1 equal to String2?
  Print At 1,1, "Equal"         ' Yes. So display Equal on line 1 of the LCD
Else                             ' Otherwise
  Print At 1,1, "Not Equal"     ' Display Not Equal on line 1 of the LCD
EndIf

String2 = "EGGS"                ' Now make the strings the same as each other
If String1 = String2 Then       ' Is String1 equal to String2?
  Print At 2,1, "Equal"         ' Yes. So display Equal on line 2 of the LCD
Else                             ' Otherwise
  Print At 2,1, "Not Equal"     ' Display Not Equal on line 2 of the LCD
EndIf
```

The example above will display not Equal on line one of the LCD because String1 contains the text "EGGS" while String2 contains the text "BACON", so they are clearly not equal.

Line two of the LCD will show Equal because String2 is then loaded with the text "EGGS" which is the same as String1, therefore the comparison is equal.

A similar example to the previous one uses a quoted character string instead of one of the **String** variables.

Example 2

' String variable to Quoted character string comparison

```
Device = 24FJ64GA002
Declare Xtal = 16

Dim String1 as String * 20      ' Create a String

Cls
String1 = "EGGS"                ' Pre-load String String1 with the text EGGS

If String1 = "BACON" Then      ' Is String1 equal to "BACON"?
    Print At 1,1, "Equal"      ' Yes. So display Equal on line 1 of the LCD
Else                            ' Otherwise...
    Print At 1,1, "Not Equal"  ' Display Not Equal on line 1 of the LCD
EndIf

If String1 = "EGGS" Then      ' Is String1 equal to "EGGS"?
    Print At 2,1, "Equal"      ' Yes. So display Equal on line 2 of the LCD
Else                            ' Otherwise...
    Print At 2,1, "Not Equal"  ' Display Not Equal on line 2 of the LCD
EndIf
```

The example above produces exactly the same results as example1 because the first comparison is clearly not equal, while the second comparison is equal.

Example 3

' Use a string comparison in a Repeat-Until loop

```
Device = 24FJ64GA002
Declare Xtal = 16

Dim SourceString as String * 20 ' Create a String
Dim DestString as String * 20  ' Create another String
Dim Charpos as Byte            ' Character position within the strings

RPOR7 = 3                      ' Make PPS Pin RP14 U1TX
Clear DestString                ' Fill DestString with nulls
SourceString = "Hello"         ' Load String SourceString with the text Hello
Repeat                          ' Create a loop
    ' Copy SourceString into DestString one character at a time
    DestString[Charpos] = SourceString[Charpos]
    Inc Charpos                  ' Move to the next character in the strings
    ' Stop when DestString is equal to the text "Hello"
Until DestString = "Hello"
HrsoutLn DestString            ' Display DestString
```

Example 4

```
' Compare a string variable to a string held in code memory
Device = 24FJ64GA002
Declare Xtal = 16

Dim String1 as String * 20      ' Create a String
Dim CodeString as Code = "EGGS", 0

Cls
String1 = "BACON"              ' Pre-load String String1 with the text BACON
If CodeString= "BACON" Then   ' Is CodeString equal to "BACON" ?
    Print At 1,1, " equal "   ' Yes. So display equal on line 1 of the LCD
Else                           ' Otherwise...
    Print At 1,1, "not equal" ' Display not equal on line 1 of the LCD
EndIf

String1 = "EGGS"              ' Pre-load String String1 with the text EGGS
If String1 = CodeString Then  ' Is String1 equal to CodeString ?
    Print At 2,1, " equal "   ' Yes. So display equal on line 2 of the LCD
Else                           ' Otherwise...
    Print At 2,1, "not equal " ' Display not equal on line 2 of the LCD
EndIf
```

Example 5

```
' String comparisons using Select-Case
Device = 24FJ64GA002
Declare Xtal = 16

Dim String1 as String * 20      ' Create a String for 20 characters

RPOR7 = 3                       ' Make PPS Pin RP14 U1TX
String1 = "EGGS"                ' Pre-load String String1 with the text EGGS
Select String1                  ' Start comparing the string
    Case "EGGS"                 ' Is String1 equal to EGGS?
        HrsoutLn "Found EGGS"
    Case "BACON"                ' Is String1 equal to BACON?
        HrsoutLn "Found BACON"
    Case "COFFEE"               ' Is String1 equal to COFFEE?
        HrsoutLn "Found COFFEE"
    Case Else                   ' Default to...
        HrsoutLn "No Match"    ' Displaying no match
EndSelect
```

See also : [Creating and using Strings](#)
[Creating and using code memory strings](#)
[If-Then-Else-EndIf, Repeat-Until](#)
[Select-Case, While-Wend .](#)

Relational Operators

Relational operators are used to compare two values. The result can be used to make a decision regarding program flow.

The list below shows the valid relational operands accepted by the compiler:

Operator	Relation	Expression Type
=	Equality	X = Y
==	Equality	X == Y (Same as above Equality)
<>	Inequality	X <> Y
<	Less than	X < Y
>	Greater than	X > Y
<=	Less than or Equal to	X <= Y
>=	Greater than or Equal to	X >= Y

See also : **If-Then-Else-EndIf, Repeat-Until, Select-Case, While-Wend.**

Boolean Logic Operators

The operators **and** and **or** join the results of two conditions to produce a single true/false result. **And** and **or** work the same as they do in everyday speech. Run the example below once with **and** (as shown) and again, substituting **or** for **and**: -

```
Device = 24FJ64GA002
Declare Xtal = 16
Dim MyByte1 as Byte
Dim MyByte2 as Byte
RPOR7 = 3 ' Make PPS Pin RP14 U1TX

MyByte1 = 5
MyByte2 = 9
If MyByte1 = 5 And MyByte2 = 10 Then GoTo Res_True
Stop
Res_True:
HrsoutLn "Result is True."
```

The condition "Var1 = 5 **and** Var2 = 10" is not true. Although Var1 is 5, Var2 is not 10. **and** works just as it does in plain English, both conditions must be true for the statement to be true. **or** also works in a familiar way; if one or the other or both conditions are true, then the statement is true.

Parenthesis (or rather the lack of it!).

Every compiler has its quirky rules, and the Proton24 compiler is no exception. One of its quirks means that parenthesis is not supported in a Boolean condition, or indeed with any of the **If-Then-Else-EndIf**, **While-Wend**, and **Repeat-Until** conditions. Parenthesis in an expression within a condition is allowed however. So, for example, the expression: -

```
If (Var1 + 3) = 10 Then do something. Is allowed.
but: -
If ((Var1 + 3) = 10) Then do something. Is not allowed.
```

The Boolean operands do have a precedence within a condition. The **and** operator has the highest priority, then the **or**, then the **xor**. This means that a condition such as: -

```
If Var1 = 2 and Var2 = 3 or Var3 = 4 Then do something
```

Will compare Var1 and Var2 to see if the **and** condition is true. It will then see if the **or** condition is true, based on the result of the **and** condition.

Then always required.

The Proton24 compiler relies heavily on the **Then** part. Therefore, if the **Then** part of a condition is left out of the code listing, a *Syntax Error* will be produced.

Math Operators

The Proton24 compiler performs all math operations in full hierarchal order. Which means that there is precedence to the operands. For example, multiplies and divides are performed before adds and subtracts. To ensure the operations are carried out in the correct order use parenthesis to group the operations: -

$$A = ((B - C) * (D + E)) / F$$

All math operations are signed or unsigned depending on the variable type used, and performed with 16, or 32-bit or floating point precision, again, depending on the variable types and constant values used within the expression.

The operators supported are: -

Standard operators

Addition '+'	Adds variables and/or constants.
Subtraction '-'	Subtracts variables and/or constants.
Multiply '**'	Multiplies variables and/or constants.
Multiply High '***'	Returns the high 16 bits of an unsigned 16-bit integer multiply.
Multiply Middle '**'	Returns the middle 16 bits of an unsigned 16-bit integer multiply.
Divide '/'	Divides variables and/or constants.
Remainder '//'	Returns the remainder after dividing one integer value by another.

Logical operators

Bitwise and '&'	Returns the logical And of two values.
Bitwise or ' '	Returns the logical Or of two values.
Bitwise xor '^'	Returns the logical Xor of two values.
Bitwise Shift Left '<<'	Shifts the bits of a value left a specified number of places.
Bitwise Shift Right '>>'	Shifts the bits of a value right a specified number of places.
Bitwise Complement '~'	Reverses the bits in a variable.

Proton24 operators

Abs	Returns the absolute value of a signed value.
Ceil	Returns the ceiling of a 32-bit floating point value.
Dcd	2 ⁿ -power decoder of a four-bit integer value.
Dig '?'	Returns the specified decimal digit of a positive integer value.
Exp	Returns the exponential function of a 32-bit floating point value.
Floor	Returns the floor of a 32-bit floating point value.
fAbs	Returns the absolute value of a 32-bit or 64-bit floating point value.
ISqr	Returns the integer Square Root of an integer value.
Modf	Split a 32-bit floating point value into its fractional and whole parts.
Ncd	Priority encoder of a 16-bit integer value.
Pow	Computes a 32-bit floating point variable to the power of another.
Rev '@'	Reverses the order of the lowest bits in an integer value.
Sqr	Returns the Square Root of a 32-bit floating point value.
dCeil	Returns the ceiling of a 64-bit floating point value.
dExp	Returns the exponential function of a 64-bit floating point value.
dFloor	Returns the floor of a 64-bit floating point value.
Modd	Split a 64-bit floating point value into its fractional and whole parts.
dPow	Computes a 64-bit floating point variable to the power of another.
dSqr	Returns the Square Root of a 64-bit floating point value.

Trigonometry functions

Acos	Returns the Arc Cosine of a 32-bit floating point value in radians.
Asin	Returns the Arc Sine of a 32-bit floating point value in radians.
Atan	Returns the Arc Tangent of a 32-bit floating point value in radians.
Cos	Returns the Cosine of a 32-bit floating point value in radians.
ISin	Returns the integer Sine of an integer value in radians.
ICos	Returns the integer Cosine of an integer value in radians.
Log	Returns the Natural Log of a 32-bit floating point value.
Log10	Returns the Log of a 32-bit floating point value.
Sin	Returns the Sine of a 32-bit floating point value in radians.
Tan	Returns the Tangent of a 32-bit floating point value in radians.
dAcos	Returns the Arc Cosine of a 64-bit floating point value in radians.
dAsin	Returns the Arc Sine of a 64-bit floating point value in radians.
dAtan	Returns the Arc Tangent of a 64-bit floating point value in radians.
dCos.	Returns the Cosine of a 64-bit floating point value in radians.
dLog	Returns the Natural Log of a 64-bit floating point value.
dLog10	Returns the Log of a 64-bit floating point value.
dSin	Returns the Sine of a 64-bit floating point value in radians.
dTan	Returns the Tangent of a 64-bit floating point value in radians.

Add '+'

Syntax

Assignment Variable = Variable + Variable

Overview

Adds variables and/or constants, returning an unsigned or signed 8, 16, 32-bit or floating point result.

Operands

Assignment Variable can be any valid variable type.

Variable can be a constant, variable or expression.

Addition works exactly as you would expect with signed and unsigned integers as well as floating point.

```
Device = 24FJ64GA002
Declare Xtal = 16

Dim MyWord1 as Word
Dim MyWord2 as Word

MyWord1 = 1575
MyWord2 = 976
MyWord1 = MyWord1 + MyWord2      ' Add the numbers.
HrsoutLn Dec MyWord1             ' Display the result

' 32-bit addition
Device = 24FJ64GA002
Declare Xtal = 16
Dim MyWord as Word
Dim MyDword as Dword

MyWord = 1575
MyDword = 9763647
MyDword = MyDword + MyWord      ' Add the numbers.
HrsoutLn Dec MyDword           ' Display the result
```

Subtract '-'

Syntax

Assignment Variable = Variable - Variable

Overview

Subtracts variables and/or constants, returning an unsigned or signed 8, 16, 32-bit or floating point result.

Operands

Assignment Variable can be any valid variable type.

Variable can be a constant, variable or expression.

Subtract works exactly as you would expect with signed and unsigned integers as well as floating point.

```
Device = 24FJ64GA002
Declare Xtal = 16
Dim MyWord1 as Word
Dim MyWord2 as Word

MyWord1 = 1000
MyWord2 = 999
MyWord1 = MyWord1 - MyWord2 ' Subtract the values.
HrsoutLn Dec MyWord1      ' Display the result
```

```
' 32-bit subtraction
Device = 24FJ64GA002
Declare Xtal = 16
Dim MyWord as Word
Dim MyDword as Dword

MyWord = 1575
MyDword = 9763647
MyDword = MyDword - MyWord ' Subtract the values.
HrsoutLn Dec MyDword      ' Display the result
```

```
' 32-bit signed subtraction
Device = 24FJ64GA002
Declare Xtal = 16
Dim MyDword1 as SDword
Dim MyDword2 as SDword

MyDword1 = 1575
MyDword2 = 9763647
MyDword1 = MyDword1 - MyDword2 ' Subtract the values.
HrsoutLn Sdec MyDword1      ' Display the result
```

Multiply '*'

Syntax

*Assignment Variable = Variable * Variable*

Overview

Multiplies variables and/or constants, returning an unsigned or signed 8, 16, 32-bit or floating point result.

Operands

Assignment Variable can be any valid variable type.

Variable can be a constant, variable or expression.

Multiply works exactly as you would expect with signed or unsigned integers from -2147483648 to +2147483647, or 0 to 4294967295, as well as floating point.

```
Device = 24FJ64GA002
Declare Xtal = 16
Dim MyWord1 as Word
Dim MyWord2 as Word

MyWord1 = 1000
MyWord2 = 19
MyWord1 = MyWord 1 * MyWord2      ' Multiply MyWord1 by MyWrd2.
HrsoutLn Dec MyWord1              ' Display the result

' 32-bit multiplication
Device = 24FJ64GA002
Declare Xtal = 16
Dim MyWord as Word
Dim MyDword as Dword

MyWord = 100
MyDword = 10000
MyDword = MyDword * MyWord        ' Multiply the numbers.
HrsoutLn Dec MyDword              ' Display the result
```

Multiply High '**'

Syntax

*Assignment Variable = Variable ** Variable*

Overview

Multiplies 8 or 16-bit unsigned variables and/or constants, returning the high 16 bits of the result.

Operands

Assignment Variable can be any valid variable type.

Variable can be a constant, variable or expression.

When multiplying two 16-bit values, the result can be as large as 32 bits. Since the largest variable supported by the compiler is 16-bits, the highest 16 bits of a 32-bit multiplication result are normally lost. The ** (double-star) operator produces these upper 16 bits.

For example, suppose 65000 (\$FDE8) is multiplied by itself. The result is 4,225,000,000 or \$FBD46240. The * (star, or normal multiplication) instruction would return the lower 16 bits, \$6240. The ** instruction returns \$FBD4.

```
Device = 24FJ64GA002
Declare Xtal = 16
Dim MyWord1 as Word
Dim MyWord2 as Word

MyWord1 = $FDE8
MyWord2 = MyWord1 ** MyWord1      ' Multiply $FDE8 by itself
HrsoutLn Hex MyWord2              ' Return high 16 bits.
```

Notes.

This operator enables compatibility with BASIC STAMP code, and melab's compiler code, but is rather obsolete considering the 32-bit capabilities of the Proton24 compiler.

Multiply Middle */

Syntax

*Assignment Variable = Variable */ Variable*

Overview

Multiplies unsigned variables and/or constants, returning the middle 16 bits of the 32-bit result.

Operands

Assignment Variable can be any valid variable type.

Variable can be a constant, variable or expression.

The Multiply Middle operator (*/) has the effect of multiplying a value by a whole number and a fraction. The whole number is the upper byte of the multiplier (0 to 255 whole units) and the fraction is the lower byte of the multiplier (0 to 255 units of 1/256 each). The */ operator allows a workaround for the compiler's integer-only math.

Suppose we are required to multiply a value by 1.5. The whole number, and therefore the upper byte of the multiplier, would be 1, and the lower byte (fractional part) would be 128, since $128/256 = 0.5$. It may be clearer to express the */ multiplier in Hex as \$0180, since hex keeps the contents of the upper and lower bytes separate. Here's an example: -

```
Device = 24FJ64GA002
Declare Xtal = 16
Dim MyWord1 as Word

MyWord1 = 100
MyWord1 = MyWord1 */ $0180      ' Multiply by 1.5 [1 + (128/256)]
HrsoutLn Dec MyWord1           ' Display result (150).
```

To calculate constants for use with the */ instruction, put the whole number portion in the upper byte, then use the following formula for the value of the lower byte: -

$$\text{int}(\text{fraction} * 256)$$

For example, take Pi (3.14159). The upper byte would be \$03 (the whole number), and the lower would be $\text{int}(0.14159 * 256) = 36$ (\$24). So the constant Pi for use with */ would be \$0324. This isn't a perfect match for Pi, but the error is only about 0.1%.

Notes.

This operator enables compatibility with BASIC STAMP code, and, to some extent, melab's compiler code, but is rather obsolete considering the 32-bit capabilities of the Proton24 compiler.

Divide '/'

Syntax

Assignment Variable = Variable / Variable

Overview

Divides variables and/or constants, returning an unsigned or signed 8, 16, 32-bit or floating point result.

Operands

Assignment Variable can be any valid variable type.

Variable can be a constant, variable or expression.

The Divide operator (/) works exactly as you would expect with signed or unsigned integers from -2147483648 to +2147483647 as well as floating point.

```
Device = 24FJ64GA002
Declare Xtal = 16
Dim MyWord1 as Word
Dim MyWord2 as Word

MyWord1 = 1000
MyWord2 = 5
MyWord1 = MyWord1 / MyWord2 ' Divide the numbers.
HrsoutLn Dec MyWord1       ' Display the result (200).
```

```
' 32-bit division
Device = 24FJ64GA002
Declare Xtal = 16
Dim MyWord as Word
Dim MyDword as Dword

MyWord = 100
MyDword = 10000
MyDword = MyDword / MyWord ' Divide the numbers.
HrsoutLn Dec MyDword      ' Display the result
```

Note

The PIC24[®] and dsPIC33[®] range of devices have an exception mechanism built into their hardware. One of these mechanisms is a trap of a division by zero on any of its instructions. The compiler attempts to avoid this state, however, it cannot guarantee that an exception will not occur, and because it is a compiled language, it cannot always give an error message for such an event.

If the BASIC code seems to reset at a particular place within the code, make sure it is not a division by 0. If a suspected division by zero will occur, wrap the division within a condition. For example:

```
If MyVar2 <> 0 Then
  DestVar = MyVar1 / MyVar2
EndIF
```

Remainder '//'

Syntax

Assignment Variable = Variable // Variable

Overview

Return the remainder left after dividing one unsigned or signed value by another.

Operands

Assignment Variable can be any valid variable type.

Variable can be a constant, variable or expression.

Some division problems don't have a whole-number result; they return a whole number and a fraction. For example, $1000/6 = 166.667$. Integer math doesn't allow the fractional portion of the result, so $1000/6 = 166$. However, 166 is an approximate answer, because $166*6 = 996$. The division operation left a remainder of 4. The // returns the remainder of a given division operation. Numbers that divide evenly, such as $1000/5$, produce a remainder of 0: -

```
Device = 24FJ64GA002
Declare Xtal = 16
Dim MyWord1 as Word
Dim MyWord2 as Word

MyWord1 = 1000
MyWord2 = 6
MyWord1 = MyWord1 // MyWord2      ' Get remainder of MyWord1 / MyWord2.
HrsoutLn Dec MyWord1              ' Display the result (4).

' 32-bit modulus
Device = 24FJ64GA002
Declare Xtal = 16
Dim MyWord as Word
Dim MyDword as Dword

MyWord = 100
MyDword = 99999
MyDword = MyDword // MyWord      ' Mod the numbers.
HrsoutLn Dec MyDword             ' Display the result
```

The modulus operator does not operate with floating point values or variables. Use **fMod** for that operation.

Note

The PIC24[®] and dsPIC33[®] range of devices have an exception mechanism built into their hardware. One of these mechanisms is a trap of a division by zero on any of its instructions. The compiler attempts to avoid this state, however, it cannot guarantee that an exception will not occur, and because it is a compiled language, it cannot always give an error message for such an event.

If the BASIC code seems to reset at a particular place within the code, make sure it is not a division by 0. If a suspected division by zero will occur, wrap the modulus within a condition. For example:

```
If MyVar2 <> 0 Then
    DestVar = MyVar1 // MyVar2
EndIF
```

Logical and '&'

The And operator (&) returns the bitwise and of two integer values. Each bit of the values is subject to the following logic: -

0 and 0 = 0
0 and 1 = 0
1 and 0 = 0
1 and 1 = 1

The result returned by & will contain 1s in only those bit positions in which both input values contain 1s: -

```
Device = 24FJ64GA002
Declare Xtal = 16
Dim MyByte1 as Byte
Dim MyByte2 as Byte
Dim MyResult as Byte
MyByte1 = %00001111
MyByte2 = %10101101
MyResult = MyByte1 & MyByte2
Hrsout Bin MyResult, 13      ' Display and result (%00001101)
```

or

```
Hrsout Bin (%00001111 & %10101101) , 13      ' Display and result (%00001101)
```

Bitwise operations are not permissible with floating point values or variables.

Logical or '|'

The Or operator (|) returns the bitwise or of two integer values. Each bit of the values is subject to the following logic: -

0 or 0 = 0
0 or 1 = 1
1 or 0 = 1
1 or 1 = 1

The result returned by | will contain 1s in any bit positions in which one or the other (or both) input values contain 1s: -

```
Device = 24FJ64GA002
Declare Xtal = 16
Dim MyByte1 as Byte
Dim MyByte2 as Byte
Dim MyResult as Byte
MyByte1 = %00001111
MyByte2 = %10101001
MyResult = MyByte1 | MyByte2
Hrsout Bin MyResult, 13      ' Display or result (%10101111)
```

or

```
Hrsout Bin (%00001111 | %10101001) , 13      ' Display or result (%10101111)
```

Bitwise operations are not permissible with floating point values or variables.

Logical Xor '^'

The Xor operator (^) returns the bitwise xor of two integer values. Each bit of the values is subject to the following logic: -

```
0 xor 0 = 0
0 xor 1 = 1
1 xor 0 = 1
1 xor 1 = 0
```

The result returned by ^ will contain 1s in any bit positions in which one or the other (but not both) input values contain 1s: -

```
Device = 24FJ64GA002
Declare Xtal = 16
Declare Hserial_Baud = 9600      ' USART1 baud rate
Declare Hrsout1_Pin = PORTB.14  ' Select the pin for TX with USART1

Dim MyByte1 as Byte
Dim MyByte2 as Byte
Dim MyResult as Byte

RPOR7 = 3                        ' Make PPS Pin RP14 U1TX

MyByte1 = %00001111
MyByte2 = %10101001
MyResult = MyByte1 ^ MyByte2
Hrsout Bin MyResult, 13         ' Display xor result (%10100110)
```

Or

```
Hrsout Bin (%00001111 ^ %10101001) , 13 ' Display xor result (%10100110)
```

Bitwise operations are not permissible with floating point values or variables.

Bitwise Shift Left '<<'

Shifts the bits of an integer value to the left a specified number of places. Bits shifted off the left end of a number are lost; bits shifted into the right end of the number are 0s. Shifting the bits of a value left n number of times also has the effect of multiplying that number by two to the n th power.

For example $100 \ll 3$ (shift the bits of the decimal number 100 left three places) is equivalent to $100 * 2^3$.

```
Device = 24FJ64GA002
Declare Xtal = 16
Declare Hserial_Baud = 9600      ' USART1 baud rate
Declare Hrsout1_Pin = PORTB.14  ' Select the pin for TX with USART1

Dim MyWord as Word
Dim Loop as Byte

RPOR7 = 3                        ' Make PPS Pin RP14 U1TX

MyWord = %1111111111111111
For Loop = 1 to 16              ' Repeat with loop = 1 to 16.
    HrsoutLn Bin MyWord << Loop ' Shift MyWord left Loop places.
Next
```

Bitwise operations are not permissible with floating point values or variables. All bit shifts are unsigned, regardless of the variable type used.

Bitwise Shift Right '>>'

Shifts the bits of an integer value to the right a specified number of places. Bits shifted off the right end of a number are lost; bits shifted into the left end of the number are 0s. Shifting the bits of a value right n number of times also has the effect of dividing that number by two to the n th power.

For example $100 \gg 3$ (shift the bits of the decimal number 100 right three places) is equivalent to $100 / 2^3$.

```
Device = 24FJ64GA002
Declare Xtal = 16
Declare Hserial_Baud = 9600      ' USART1 baud rate
Declare Hrsout1_Pin = PORTB.14  ' Select the pin for TX with USART1

Dim MyWord as Word
Dim Loop as Byte

RPOR7 = 3                        ' Make PPS Pin RP14 U1TX

MyWord = %1111111111111111
For Loop = 1 to 16                ' Repeat with loop = 1 to 16.
    HrsoutLn Bin MyWord >> Loop  ' Shift MyWord right Loop places.
Next
```

Complement '~'

The Complement operator (~) inverts the bits of an integer value. Each bit that contains a 1 is changed to 0 and each bit containing 0 is changed to 1. This process is also known as a "bit-wise not".

```
Device = 24FJ64GA002
Declare Xtal = 16
Declare Hserial_Baud = 9600      ' USART1 baud rate
Declare Hrsout1_Pin = PORTB.14  ' Select the pin for TX with USART1

Dim MyWord1 as Word
Dim MyWord2 as Word

RPOR7 = 3                        ' Make PPS Pin RP14 U1TX

MyWord2 = %1111000011110000
MyWord1 = ~MyWord2              ' Complement MyWord2.
HrsoutLn Bin16 MyWord1         ' Display the result
```

Complementing can be carried out with all variable types except **Floats**. Attempting to complement a floating point variable will produce a syntax error. All bit shifts are unsigned, regardless of the variable type used.

Abs

Syntax

Assignment Variable = **Abs**(*Variable*)

Overview

Return the absolute value of a constant, variable or expression.

Operands

Assignment Variable can be any valid variable type.

Variable can be a constant, variable or expression.

32-bit Example

```
Device = 24FJ64GA002
Declare Xtal = 16

Dim MyDword1 as Dword      ' Create an unsigned Dword variable
Dim MyDword2 as Dword      ' Create an unsigned Dword variable

MyDword1 = -1234567        ' Load MyDword1 with value -1234567
MyDword2 = Abs(MyDword1)   ' Extract the absolute value from MyDword1
Hrsout Dec MyDword2, 13    ' Display the result, which is 1234567
```

32-bit Floating Point example

```
Device = 24FJ64GA002
Declare Xtal = 16

Dim MyFloat1 as Float      ' Create a Float variable
Dim MyFloat2 as Float      ' Create a Float variable

RPOR7 = 3                  ' Make PPS Pin RP14 U1TX

MyFloat1 = -12345          ' Load MyFloat1 with value -12345
MyFloat2 = Abs(MyFloat1)   ' Extract the absolute value from MyFloat1
Hrsout Dec MyFloat2, 13    ' Display the result, which is 12345
```

64-bit Floating Point example

```
Device = 24FJ64GA002
Declare Xtal = 16
Declare Hserial_Baud = 9600 ' USART1 baud rate
Declare Hrsout1_Pin = PORTB.14 ' Select the pin for TX with USART1

Dim MyDouble1 as Double    ' Create a Double variable
Dim MyDouble2 as Double    ' Create a Double variable

RPOR7 = 3                  ' Make PPS Pin RP14 U1TX

MyDouble1 = -12345         ' Load MyDouble1 with value -12345
MyDouble2 = Abs(MyDouble1) ' Extract the absolute value from MyDouble1
Hrsout Dec MyDouble2, 13   ' Display the result, which is 12345
```

Note.

When implementing trigonometry, or other built in, functions within an expression, always wrap them in parenthesis, otherwise the parser may consider the extra operands as part of the trigonometry parameter and produce an incorrect result. For example:

```
MyAssignment = (Abs(MyVar1)) + (ISin(MyVar2))
```

fAbs

Syntax

Assignment Variable = **fAbs**(*Variable*)

Overview

Return the absolute value of a constant, variable or expression as 32-bit floating point.

Operands

Assignment Variable can be any valid variable type.

Variable can be a constant, variable or expression.

Example

```
Device = 24FJ64GA002
Declare Xtal = 16
Declare Hserial_Baud = 9600      ' USART1 baud rate
Declare Hrsout1_Pin = PORTB.14  ' Select the pin for TX with USART1

Dim MyFloat as Float           ' Create a Float variable
Dim Floatout as Float          ' Create a Float variable

RPOR7 = 3                      ' Make PPS Pin RP14 U1TX

MyFloat = -3.14                 ' Load MyFloat with value -3.14
Floatout = fAbs(MyFloat)       ' Extract the absolute value from MyFloat
Hrsout Dec Floatout, 13        ' Display the result, which is 3.14
```

Note.

When implementing trigonometry, or other built in, functions within an expression, always wrap them in parenthesis, otherwise the parser may consider the extra operands as part of the trigonometry parameter and produce an incorrect result. For example:

```
MyAssignment = (fAbs(MyVar1)) + (Sin(MyVar2))
```

dAbs

Syntax

Assignment Variable = **dAbs**(*Variable*)

Overview

Return the absolute value of a constant, variable or expression as 64-bit floating point.

Operands

Assignment Variable can be any valid variable type.

Variable can be a constant, variable or expression.

Example

```
Device = 24FJ64GA002
Declare Xtal = 16
Declare Hserial_Baud = 9600      ' USART1 baud rate
Declare Hrsout1_Pin = PORTB.14  ' Select the pin for TX with USART1

Dim MyDouble as Double          ' Create a Double variable
Dim Doubleout as Double         ' Create a Double variable

RPOR7 = 3                       ' Make PPS Pin RP14 U1TX

MyDouble = -3.14                 ' Load My Double with value -3.14
Doubleout = dAbs(MyDouble)      ' Extract the absolute value from My Double
Hrsout Dec Doubleout, 13        ' Display the result, which is 3.14
```

Note.

When implementing trigonometry, or other built in, functions within an expression, always wrap them in parenthesis, otherwise the parser may consider the extra operands as part of the trigonometry parameter and produce an incorrect result. For example:

```
MyAssignment = (dAbs(MyVar1)) + (dSin(MyVar2))
```

Acos

Syntax

Assignment Variable = **Acos**(Variable)

Overview

Deduce the Arc Cosine of a 32-bit floating point value

Operands

Assignment Variable can be any valid variable type.

Variable can be a constant, variable or expression that requires the Arc Cosine (Inverse Cosine) extracted. The value expected and returned by the floating point **Acos** is in radians. The value must be in the range of -1 to +1

Example

```
Device = 24FJ64GA002
Declare Xtal = 16
Declare Hserial_Baud = 9600      ' USART1 baud rate
Declare Hrsout1_Pin = PORTB.14  ' Select the pin for TX with USART1

Dim Floatin as Float           ' Holds the value to Acos
Dim Floatout as Float         ' Holds the result of the Acos

RPOR7 = 3                      ' Make PPS Pin RP14 U1TX

Floatin = 0.8                  ' Load the variable
Floatout = Acos(Floatin)      ' Extract the Acos of the value
Hrsout Dec Floatout, 13       ' Display the result
```

Notes.

Floating point trigonometry is rather memory hungry, so do not be surprised if a large chunk of the microcontroller's code memory is used with a single operator. This also means that floating point trigonometry is comparatively slow to operate.

When implementing trigonometry, or other built in, functions within an expression, always wrap them in parenthesis, otherwise the parser may consider the extra operands as part of the trigonometry parameter and produce an incorrect result. For example:

```
MyAssignment = (Acos(MyVar1)) + (Sin(MyVar2))
```

dAcos

Syntax

Assignment Variable = **dAcos**(Variable)

Overview

Deduce the Arc Cosine of a 64-bit floating point value

Operands

Assignment Variable can be any valid variable type.

Variable can be a constant, variable or expression that requires the Arc Cosine (Inverse Cosine) extracted. The value expected and returned by the 64-bit floating point **dAcos** is in radians. The value must be in the range of -1 to +1

Example

```
Device = 24FJ64GA002
Declare Xtal = 16
Declare Hserial_Baud = 9600      ' USART1 baud rate
Declare Hrsout1_Pin = PORTB.14  ' Select the pin for TX with USART1

Dim Doublein as Double          ' Holds the value to Acos
Dim Doubleout as Double         ' Holds the result of the Acos

RPOR7 = 3                       ' Make PPS Pin RP14 U1TX

Doublein = 0.8                  ' Load the variable
Doubleout = dAcos(Doublein)      ' Extract the Acos of the value
Hrsout Dec Doubleout, 13        ' Display the result
```

Notes.

64-bit floating point trigonometry is very memory hungry, so do not be surprised if a large chunk of the microcontroller's code memory is used with a single operator. This also means that floating point trigonometry is comparatively slow to operate.

When implementing trigonometry, or other built in, functions within an expression, always wrap them in parenthesis, otherwise the parser may consider the extra operands as part of the trigonometry parameter and produce an incorrect result. For example:

```
MyAssignment = (dAcos(MyVar1)) + (dSin(MyVar2))
```

Asin

Syntax

Assignment Variable = **Asin**(*Variable*)

Overview

Deduce the Arc Sine of a 32-bit floating point value

Operands

Assignment Variable can be any valid variable type.

Variable can be a constant, variable or expression that requires the Arc Sine (Inverse Sine) extracted. The value expected and returned by **Asin** is in radians. The value must be in the range of -1 to +1

Example

```
Device = 24FJ64GA002
Declare Xtal = 16
Declare Hserial_Baud = 9600      ' USART1 baud rate
Declare Hrsout1_Pin = PORTB.14  ' Select the pin for TX with USART1

Dim Floatin as Float           ' Holds the value to Asin
Dim Floatout as Float          ' Holds the result of the Asin

RPOR7 = 3                      ' Make PPS Pin RP14 U1TX

Floatin = 0.8                  ' Load the variable
Floatout = Asin(Floatin)      ' Extract the Asin of the value
Hrsout Dec Floatout, 13       ' Display the result
```

Notes.

Floating point trigonometry is rather memory hungry, so do not be surprised if a large chunk of the microcontroller's code memory is used with a single operator. This also means that floating point trigonometry is comparatively slow to operate compared to integer maths.

When implementing trigonometry, or other built in, functions within an expression, always wrap them in parenthesis, otherwise the parser may consider the extra operands as part of the trigonometry parameter and produce an incorrect result. For example:

```
MyAssignment = (Asin(MyVar1)) + (Sin(MyVar2))
```

dAsin

Syntax

Assignment Variable = **dAsin**(Variable)

Overview

Deduce the Arc Sine of a 64-bit floating point value

Operands

Assignment Variable can be any valid variable type.

Variable can be a constant, variable or expression that requires the Arc Sine (Inverse Sine) extracted. The value expected and returned by **dAsin** is in radians. The value must be in the range of -1 to +1

Example

```
Device = 24FJ64GA002
Declare Xtal = 16
Declare Hserial_Baud = 9600      ' USART1 baud rate
Declare Hrsout1_Pin = PORTB.14  ' Select the pin for TX with USART1

Dim Doublein as Double          ' Holds the value to Asin
Dim Doubleout as Double         ' Holds the result of the Asin

RPOR7 = 3                       ' Make PPS Pin RP14 U1TX

Doublein = 0.8                   ' Load the variable
Doubleout = dAsin(Doublein)      ' Extract the Asin of the value
Hrsout Dec Doubleout, 13        ' Display the result
```

Notes.

64-bit floating point trigonometry is very memory hungry, so do not be surprised if a large chunk of the microcontroller's code memory is used with a single operator. This also means that floating point trigonometry is comparatively slow to operate compared to integer maths.

The compiler uses the stack as temporary storage when performing 64-bit floating point library routines, therefore, it may be required to increase the stack size from the default 120 words to 200 words using the **Stack_Size** declare. If the program resets with a stack underflow/overflow exception when running, the stack size is insufficient and requires increasing.

When implementing trigonometry, or other built in, functions within an expression, always wrap them in parenthesis, otherwise the parser may consider the extra operands as part of the trigonometry parameter and produce an incorrect result. For example:

```
MyAssignment = (dAsin(MyVar1)) + (dSin(MyVar2))
```

Atan

Syntax

Assignment Variable = **Atan**(Variable)

Overview

Deduce the arc tangent of a 32-bit floating point value.

Operands

Assignment Variable can be any valid variable type.

Variable can be a constant, variable or expression that requires the arc tangent (Inverse Tangent) extracted. The value expected and returned by the floating point **Atan** is in radians.

Example

```
Device = 24FJ64GA002
Declare Xtal = 16
Declare Hserial_Baud = 9600      ' USART1 baud rate
Declare Hrsout1_Pin = PORTB.14  ' Select the pin for TX with USART1

Dim Floatin as Float           ' Holds the value to Atan
Dim Floatout as Float         ' Holds the result of the Atan

RPOR7 = 3                      ' Make PPS Pin RP14 U1TX

Floatin = 1                    ' Load the variable
Floatout = Atan(Floatin)      ' Extract the Atan of the value
Hrsout Dec Floatout, 13       ' Display the result
```

Notes.

Floating point trigonometry is rather memory hungry, so do not be surprised if a large chunk of the microcontroller's code memory is used with a single operator. This also means that floating point trigonometry is comparatively slow to operate.

When implementing trigonometry, or other built in, functions within an expression, always wrap them in parenthesis, otherwise the parser may consider the extra operands as part of the trigonometry parameter and produce an incorrect result. For example:

```
MyAssignment = (dAtan(MyVar1)) + (dsin(MyVar2))
```

dAtan

Syntax

Assignment Variable = **dAtan**(*Variable*)

Overview

Deduce the arc tangent of a 64-bit floating point value.

Operands

Assignment Variable can be any valid variable type.

Variable can be a constant, variable or expression that requires the arc tangent (Inverse Tangent) extracted. The value expected and returned by the floating point **Atan** is in radians.

Example

```
Device = 24FJ64GA002
Declare Xtal = 16
Declare Hserial_Baud = 9600      ' USART1 baud rate
Declare Hrsout1_Pin = PORTB.14  ' Select the pin for TX with USART1

Dim Doublein as Double          ' Holds the value to Atan
Dim Doubleout as Double         ' Holds the result of the Atan

RPOR7 = 3                       ' Make PPS Pin RP14 U1TX

Doublein = 1                    ' Load the variable
Doubleout = dAtan(Doublein)      ' Extract the Atan of the value
Hrsout Dec Doubleout, 13        ' Display the result
```

Notes.

64-bit floating point trigonometry is very memory hungry, so do not be surprised if a large chunk of the microcontroller's code memory is used with a single operator. This also means that floating point trigonometry is comparatively slow to operate.

The compiler uses the stack as temporary storage when performing 64-bit floating point library routines, therefore, it may be required to increase the stack size from the default 120 words to 200 words using the **Stack_Size** declare. If the program resets with a stack underflow/overflow exception when running, the stack size is insufficient and requires increasing.

When implementing trigonometry, or other built in, functions within an expression, always wrap them in parenthesis, otherwise the parser may consider the extra operands as part of the trigonometry parameter and produce an incorrect result. For example:

```
MyAssignment = (dAtan(MyVar1)) + (dCos(MyVar2))
```

Atan2

Syntax

Assignment Variable = **Atan2**(yVariable, xVariable)

Overview

Deduce the arc tangent of 32-bit floating point y/x.

Operands

Assignment Variable can be any valid variable type.

y Variable can be a constant, variable or expression that requires the arc tangent (Inverse Tangent) extracted. The value expected and returned by the floating point **Atan2** is in radians.

x Variable can be a constant, variable or expression that requires the arc tangent (Inverse Tangent) extracted. The value expected and returned by the floating point **Atan2** is in radians.

Example

```
Device = 24FJ64GA002
Declare Xtal = 16
Declare Hserial_Baud = 9600      ' USART1 baud rate
Declare Hrsout1_Pin = PORTB.14  ' Select the pin for TX with USART1

Dim Floatin1 as Float
Dim Floatin2 as Float

Dim Floatout as Float           ' Holds the result of Atan2

RPOR7 = 3                      ' Make PPS Pin RP14 U1TX

Floatin1 = 3
Floatin2 = 3.4

Floatout = Atan2(Floatin1, Floatin2) ' Extract the Atan2 of the values
Hrsout Dec Floatout, 13          ' Display the result
```

Notes.

Floating point trigonometry is rather memory hungry, so do not be surprised if a large chunk of the microcontroller's code memory is used with a single operator. This also means that floating point trigonometry is comparatively slow to operate.

When implementing trigonometry, or other built in, functions within an expression, always wrap them in parenthesis, otherwise the parser may consider the extra operands as part of the trigonometry parameter and produce an incorrect result. For example:

```
MyAssignment = (Atan2(MyVar1, MyVar2)) + (Tan(MyVar3))
```

dAtan2

Syntax

Assignment Variable = **dAtan2**(*yVariable*, *xVariable*)

Overview

Deduce the arc tangent of 64-bit floating point y/x.

Operands

Assignment Variable can be any valid variable type.

y Variable can be a constant, variable or expression that requires the arc tangent (Inverse Tangent) extracted. The value expected and returned by the 64-bit floating point **dAtan2** is in radians.

x Variable can be a constant, variable or expression that requires the arc tangent (Inverse Tangent) extracted. The value expected and returned by the 64-bit floating point **dAtan2** is in radians.

Example

```
Device = 24FJ64GA002
Declare Xtal = 16
Declare Hserial_Baud = 9600      ' USART1 baud rate
Declare Hrsout1_Pin = PORTB.14  ' Select the pin for TX with USART1

Dim Doublein1 as Double
Dim Doublein2 as Double

Dim Doubleout as Double        ' Holds the result of Atan2

RPOR7 = 3                      ' Make PPS Pin RP14 U1TX

Doublein1 = 3
Doublein2 = 3.4

Doubleout = dAtan2(Doublein1, Doublein2) ' Perfrom the Atan of the values
Hrsout Dec Doubleout, 13        ' Display the result
```

Notes.

64-bit floating point trigonometry is very memory hungry, so do not be surprised if a large chunk of the microcontroller's code memory is used with a single operator. This also means that floating point trigonometry is comparatively slow to operate.

The compiler uses the stack as temporary storage when performing 64-bit floating point library routines, therefore, it may be required to increase the stack size from the default 120 words to 200 words using the **Stack_Size** declare. If the program resets with a stack underflow/overflow exception when running, the stack size is insufficient and requires increasing.

When implementing trigonometry, or other built in, functions within an expression, always wrap them in parenthesis, otherwise the parser may consider the extra operands as part of the trigonometry parameter and produce an incorrect result. For example:

```
MyAssignment = (dAtan2(MyVar1, MyVar2)) + (dsin(MyVar3))
```

Ceil

Syntax

Assignment Variable = **Ceil**(*Variable*)

Overview

Deduce the ceil of a 32-bit floating point value. Returns the smallest whole value greater than or equal to *Variable*.

Operands

Assignment Variable can be any valid variable type.

Variable can be a floating point constant, variable or expression.

Example

```
Device = 24FJ64GA002
Declare Xtal = 16
Declare Hserial_Baud = 9600      ' USART1 baud rate
Declare Hrsout1_Pin = PORTB.14  ' Select the pin for TX with USART1

Dim Floatin as Float           ' Holds the value to Ceil
Dim Floatout as Float          ' Holds the result of the Ceil

RPOR7 = 3                      ' Make PPS Pin RP14 U1TX

Floatin = 3.8                  ' Load the variable
Floatout = Ceil(Floatin)      ' Extract the ceil value
Hrsout Dec Floatout, 13       ' Display the result (4.0)
```

Note.

When implementing trigonometry, or other built in, functions within an expression, always wrap them in parenthesis, otherwise the parser may consider the extra operands as part of the trigonometry parameter and produce an incorrect result. For example:

```
MyAssignment = (Ceil(MyVar1)) + (Sin(MyVar2))
```

dCeil

Syntax

Assignment Variable = **dCeil**(*Variable*)

Overview

Deduce the ceil of a 64-bit floating point value. Returns the smallest whole value greater than or equal to *Variable*.

Operands

Assignment Variable can be any valid variable type.

Variable can be a floating point constant, variable or expression.

Example

```
Device = 24FJ64GA002
Declare Xtal = 16
Declare Hserial_Baud = 9600      ' USART1 baud rate
Declare Hrsout1_Pin = PORTB.14  ' Select the pin for TX with USART1

Dim Doublein as Double          ' Holds the value to Ceil
Dim Doubleout as Double         ' Holds the result of the Ceil

RPOR7 = 3                       ' Make PPS Pin RP14 U1TX

Doublein = 3.8                  ' Load the variable
Doubleout = dCeil(Doublein)      ' Extract the ceil value
Hrsout Dec Doubleout, 13        ' Display the result (4.0)
```

Note.

When implementing trigonometry, or other built in, functions within an expression, always wrap them in parenthesis, otherwise the parser may consider the extra operands as part of the trigonometry parameter and produce an incorrect result. For example:

```
MyAssignment = (dCeil(MyVar1)) + MyVar2
```

Cos

Syntax

Assignment Variable = **Cos**(Variable)

Overview

Deduce the Cosine of a 32-bit floating point value

Operands

Assignment Variable can be any valid variable type.

Variable can be a constant, variable or expression that requires the Cosine extracted. The value expected and returned by **Cos** is in radians.

Example

```
Device = 24FJ64GA002
Declare Xtal = 16
Declare Hserial_Baud = 9600      ' USART1 baud rate
Declare Hrsout1_Pin = PORTB.14  ' Select the pin for TX with USART1

Dim Floatin as Float           ' Holds the value to Cos with
Dim Floatout as Float          ' Holds the result of the Cos

RPOR7 = 3                      ' Make PPS Pin RP14 U1TX

Floatin = 123                  ' Load the variable
Floatout = Cos(Floatin)        ' Extract the Cosine of the value
Hrsout Dec Floatout, 13        ' Display the result
```

Notes.

Floating point trigonometry is rather memory hungry, so do not be surprised if a large chunk of the microcontroller's code memory is used with a single operator. This also means that floating point trigonometry is comparatively slow to operate.

When implementing trigonometry, or other built in, functions within an expression, always wrap them in parenthesis, otherwise the parser may consider the extra operands as part of the trigonometry parameter and produce an incorrect result. For example:

```
MyAssignment = (Cos(MyVar1)) + MyVar2
```

dCos

Syntax

Assignment Variable = **dCos**(*Variable*)

Overview

Deduce the Cosine of a 64-bit floating point value

Operands

Assignment Variable can be any valid variable type.

Variable can be a constant, variable or expression that requires the Cosine extracted. The value expected and returned by **dCos** is in radians.

Example

```
Device = 24FJ64GA002
Declare Xtal = 16
Declare Hserial_Baud = 9600      ' USART1 baud rate
Declare Hrsout1_Pin = PORTB.14  ' Select the pin for TX with USART1

Dim Doublein as Double          ' Holds the value to Cos with
Dim Doubleout as Double         ' Holds the result of the Cos

RPOR7 = 3                       ' Make PPS Pin RP14 U1TX

Doublein = 123                  ' Load the variable
Doubleout = dCos(Doublein)      ' Extract the Cosine of the value
Hrsout Dec Doubleout, 13       ' Display the result
```

Notes.

64-bit floating point trigonometry is very memory hungry, so do not be surprised if a large chunk of the microcontroller's code memory is used with a single operator. This also means that floating point trigonometry is comparatively slow to operate.

The compiler uses the stack as temporary storage when performing 64-bit floating point library routines, therefore, it may be required to increase the stack size from the default 120 words to 200 words using the **Stack_Size** declare. If the program resets with a stack underflow/overflow exception when running, the stack size is insufficient and requires increasing.

When implementing trigonometry, or other built in, functions within an expression, always wrap them in parenthesis, otherwise the parser may consider the extra operands as part of the trigonometry parameter and produce an incorrect result. For example:

```
MyAssignment = (dCos(MyVar1)) + MyVar2
```

Dcd

2 n -power decoder of a four-bit value. **Dcd** accepts a value from 0 to 15, and returns a 16-bit number with that bit number set to 1. For example: -

```
Device = 24FJ64GA002
Declare Xtal = 16
Declare Hserial_Baud = 9600      ' USART1 baud rate
Declare Hrsout1_Pin = PORTB.14  ' Select the pin for TX with USART1

Dim MyWord1 as Word

RPOR7 = 3                        ' Make PPS Pin RP14 UITX

MyWord1= Dcd 12                  ' Set bit 12.
HrsoutLn Bin16 MyWord1          ' Display result (%0001000000000000)
```

Dcd does not (as yet) support **Double**, **Float** or **Dword** type variables. Therefore the highest value obtainable is 65535.

Dig '?'

In this form, the ? operator is compatible with the BASIC Stamp, and the melab's PICBASIC Pro compiler. ? returns the specified decimal digit of a 16-bit positive value. Digits are numbered from 0 (the rightmost digit) to 4 (the leftmost digit of a 16- bit number; 0 to 65535). Example: -

```
Device = 24FJ64GA002
Declare Xtal = 16
Declare Hserial_Baud = 9600      ' USART1 baud rate
Declare Hrsout1_Pin = PORTB.14  ' Select the pin for TX with USART1

Dim Loop as Byte
Dim MyWord1 as Word

RPOR7 = 3                        ' Make PPS Pin RP14 UITX

MyWord1= 9742
Hrsout MyWord1 ? 2, 13          ' Display digit 2 (7)
For Loop = 0 to 4
    HrsoutLn MyWord1 ? Loop     ' Display digits 0 through 4 of 9742.
Next
```

Note

Dig does not support **Double**, **Float** or **Dword** type variables.

Exp

Syntax

Assignment Variable = **Exp**(*Variable*)

Overview

Deduce the exponential function of a 32-bit floating point value. This is e to the power of *value* where e is the base of natural logarithms. **Exp** 1 is 2.7182818.

Operands

Assignment Variable can be any valid variable type.

Variable can be a constant, variable or expression.

Example

```
Device = 24FJ64GA002
Declare Xtal = 16
Declare Hserial_Baud = 9600      ' USART1 baud rate
Declare Hrsout1_Pin = PORTB.14  ' Select the pin for TX with USART1

Dim Floatin as Float           ' Holds the value to Exp with
Dim Floatout as Float         ' Holds the result of the Exp

RPOR7 = 3                      ' Make PPS Pin RP14 U1TX

Floatin = 1                    ' Load the variable
Floatout = Exp(Floatin)       ' Extract the Exp of the value
HrsoutLn Dec Floatout         ' Display the result
```

Notes.

Floating point trigonometry is rather memory hungry, so do not be surprised if a large chunk of the microcontroller's code memory is used with a single operator. This also means that floating point trigonometry is comparatively slow to operate.

When implementing trigonometry, or other built in, functions within an expression, always wrap them in parenthesis, otherwise the parser may consider the extra operands as part of the trigonometry parameter and produce an incorrect result. For example:

```
MyAssignment = (Exp(MyVar1)) + MyVar2
```

dExp

Syntax

Assignment Variable = **dExp**(*Variable*)

Overview

Deduce the exponential function of a 64-bit floating point value. This is e to the power of *value* where e is the base of natural logarithms. **dExp** 1 is 2.7182818.

Operands

Assignment Variable can be any valid variable type.

Variable can be a constant, variable or expression.

Example

```
Device = 24FJ64GA002
Declare Xtal = 16
Declare Hserial_Baud = 9600      ' USART1 baud rate
Declare Hrsout1_Pin = PORTB.14  ' Select the pin for TX with USART1

Dim Doublein as Double          ' Holds the value to Exp with
Dim Doubleout as Double         ' Holds the result of the Exp

RPOR7 = 3                       ' Make PPS Pin RP14 U1TX

Doublein = 1                    ' Load the variable
Doubleout = dExp(Doublein)       ' Extract the Exp of the value
HrsoutLn Dec Doubleout, 13      ' Display the result
```

Notes.

64-bit floating point trigonometry is very memory hungry, so do not be surprised if a large chunk of the microcontroller's code memory is used with a single operator. This also means that floating point trigonometry is comparatively slow to operate.

The compiler uses the stack as temporary storage when performing 64-bit floating point library routines, therefore, it may be required to increase the stack size from the default 120 words to 200 words using the **Stack_Size** declare. If the program resets with a stack underflow/overflow exception when running, the stack size is insufficient and requires increasing.

When implementing trigonometry, or other built in, functions within an expression, always wrap them in parenthesis, otherwise the parser may consider the extra operands as part of the trigonometry parameter and produce an incorrect result. For example:

```
MyAssignment = (dExp(MyVar1)) + MyVar2
```

Floor

Syntax

Assignment Variable = **Floor**(*Variable*)

Overview

Deduce the floor of a 32-bit floating point value. Returns the largest whole value less than or equal to *Variable*.

Operands

Assignment Variable can be any valid variable type.

Variable can be a floating point constant, variable or expression.

Example

```
Device = 24FJ64GA002
Declare Xtal = 16
Declare Hserial_Baud = 9600      ' USART1 baud rate
Declare Hrsout1_Pin = PORTB.14  ' Select the pin for TX with USART1

Dim Floatin as Float           ' Holds the value to Asin
Dim Floatout as Float          ' Holds the result of the Asin

RPOR7 = 3                      ' Make PPS Pin RP14 U1TX

Floatin = 3.8                  ' Load the variable
Floatout = Floor(Floatin)      ' Extract the floor value
HrsoutLn Dec Floatout          ' Display the result (3.0)
```

Note.

When implementing trigonometry, or other built in, functions within an expression, always wrap them in parenthesis, otherwise the parser may consider the extra operands as part of the trigonometry parameter and produce an incorrect result. For example:

```
MyAssignment = (Floor(MyVar1)) + MyVar2
```

dFloor

Syntax

Assignment Variable = **dFloor**(*Variable*)

Overview

Deduce the floor of a 64-bit floating point value. Returns the largest whole value less than or equal to *Variable*.

Operands

Assignment Variable can be any valid variable type.

Variable can be a floating point constant, variable or expression.

Example

```
Device = 24FJ64GA002
Declare Xtal = 16
Declare Hserial_Baud = 9600      ' USART1 baud rate
Declare Hrsout1_Pin = PORTB.14  ' Select the pin for TX with USART1

Dim Doublein as Double          ' Holds the value to Asin
Dim Doubleout as Double         ' Holds the result of the Asin

RPOR7 = 3                       ' Make PPS Pin RP14 U1TX

Doublein = 3.8                  ' Load the variable
Doubleout = dFloor(Doublein)     ' Extract the floor value
HrsoutLn Dec Doubleout          ' Display the result (3.0)
```

Notes.

The compiler uses the stack as temporary storage when performing 64-bit floating point library routines, therefore, it may be required to increase the stack size from the default 120 words to 200 words using the **Stack_Size** declare. If the program resets with a stack underflow/overflow exception when running, the stack size is insufficient and requires increasing.

When implementing trigonometry, or other built in, functions within an expression, always wrap them in parenthesis, otherwise the parser may consider the extra operands as part of the trigonometry parameter and produce an incorrect result. For example:

```
MyAssignment = (dFloor(MyVar1)) + MyVar2
```

fRound

Syntax

Assignment Variable = **fRound**(*Variable*)

Overview

Round a 32-bit floating point value, variable or expression to the nearest whole number.

Operands

Assignment Variable can be any valid variable type.

Variable can be a constant, variable or expression.

Example 1

```
Device = 24FJ64GA002
Declare Xtal = 16
Declare Hserial_Baud = 9600 ' USART1 baud rate
Declare Hrsout1_Pin = PORTB.14 ' Select the pin for TX with USART1

Dim Floatin as Float ' Holds the value to round
Dim Dwordout as Dword ' Holds the result of fRound

RPOR7 = 3 ' Make PPS Pin RP14 U1TX

Floatin = 1.9 ' Load the variable
Dwordout = fRound(Floatin) ' Round to the nearest whole value
HrsoutLn Dec Dwordout ' Display the integer result (which is 2)
```

Example 2

```
Device = 24FJ64GA002
Declare Xtal = 16
Declare Hserial_Baud = 9600 ' USART1 baud rate
Declare Hrsout1_Pin = PORTB.14 ' Select the pin for TX with USART1

Dim Floatin as Float ' Holds the value to round
Dim Dwordout as Dword ' Holds the result of fRound

RPOR7 = 3 ' Make PPS Pin RP14 U1TX

Floatin = 1.2 ' Load the variable
Dwordout = fRound(Floatin) ' Round to the nearest whole value
HrsoutLn Dec Dwordout ' Display the integer result (which is 1)
```

Notes.

Floating point routines are rather memory hungry, so do not be surprised if a large chunk of the microcontroller's code memory is used with a single operator. This also means that floating point trigonometry is comparatively slow to operate.

When implementing trigonometry, or other built in, functions within an expression, always wrap them in parenthesis, otherwise the parser may consider the extra operands as part of the trigonometry parameter and produce an incorrect result. For example:

```
MyAssignment = (fRound(MyVar1)) + MyVar2
```

dRound

Syntax

Assignment Variable = **dRound**(*Variable*)

Overview

Round a 64-bit floating point value, variable or expression to the nearest whole number.

Operands

Assignment Variable can be any valid variable type.

Variable can be a constant, variable or expression.

Example 1

```
Device = 24FJ64GA002
Declare Xtal = 16
Declare Hserial_Baud = 9600 ' USART1 baud rate
Declare Hrsout1_Pin = PORTB.14 ' Select the pin for TX with USART1

Dim Doublein as Double ' Holds the value to round
Dim Dwordout as Dword ' Holds the result of dRound

RPOR7 = 3 ' Make PPS Pin RP14 U1TX

Doublein = 1.9 ' Load the variable
Dwordout = dRound(Doublein) ' Round to the nearest whole value
HrsoutLn Dec Dwordout ' Display the integer result (which is 2)
```

Example 2

```
Device = 24FJ64GA002
Declare Xtal = 16
Declare Hserial_Baud = 9600 ' USART1 baud rate
Declare Hrsout1_Pin = PORTB.14 ' Select the pin for TX with USART1

Dim Doublein as Double ' Holds the value to round
Dim Dwordout as Dword ' Holds the result of dRound

RPOR7 = 3 ' Make PPS Pin RP14 U1TX

Doublein = 1.2 ' Load the variable
Dwordout = dRound(Doublein) ' Round to the nearest whole value
Hrsout Dec Dwordout, 13 ' Display the integer result (which is 1)
```

Notes.

64-bit floating point routines are very memory hungry, so do not be surprised if a large chunk of the microcontroller's code memory is used with a single operator. This also means that floating point trigonometry is comparatively slow to operate.

The compiler uses the stack as temporary storage when performing 64-bit floating point library routines, therefore, it may be required to increase the stack size from the default 120 words to 200 words using the **Stack_Size** declare. If the program resets with a stack underflow/overflow exception when running, the stack size is insufficient and requires increasing.

Note.

When implementing trigonometry, or other built in, functions within an expression, always wrap them in parenthesis, otherwise the parser may consider the extra operands as part of the trigonometry parameter and produce an incorrect result. For example:

```
MyAssignment = (dRound(MyVar1)) + MyVar2
```

ISin

Syntax

Assignment Variable = **ISin**(*Variable*)

Overview

Deduce the integer Sine of an integer value

Operands

Assignment Variable can be any valid variable type.

Variable can be a constant, variable or expression that requires the Sine extracted. The value expected and returned by **ISin** is in decimal radians (0 to 255).

Example

```
Device = 24FJ64GA002
Declare Xtal = 16
Declare Hserial_Baud = 9600      ' USART1 baud rate
Declare Hrsout1_Pin = PORTB.14  ' Select the pin for TX with USART1

Dim ByteIn as Byte              ' Holds the value to Sin
Dim ByteOut as Byte             ' Holds the result of the Sin

RPOR7 = 3                       ' Make PPS Pin RP14 U1TX

ByteIn = 123                    ' Load the variable
ByteOut = ISin(ByteIn)          ' Extract the integer Sin of the value
HrsoutLn Dec ByteOut            ' Display the result
```

Note.

When implementing trigonometry, or other built in, functions within an expression, always wrap them in parenthesis, otherwise the parser may consider the extra operands as part of the trigonometry parameter and produce an incorrect result. For example:

```
MyAssignment = (ISin(MyVar1)) + MyVar2
```

ICos

Syntax

Assignment Variable = **ICos**(*Variable*)

Overview

Deduce the integer Cosine of an integer value

Operands

Assignment Variable can be any valid variable type.

Variable can be a constant, variable or expression that requires the Cosine extracted. The value expected and returned by **ICos** is in decimal radians (0 to 255).

Example

```
Device = 24FJ64GA002
Declare Xtal = 16
Declare Hserial_Baud = 9600      ' USART1 baud rate
Declare Hrsout1_Pin = PORTB.14  ' Select the pin for TX with USART1

Dim ByteIn as Byte              ' Holds the value to Cos
Dim ByteOut as Byte             ' Holds the result of the Cos

RPOR7 = 3                       ' Make PPS Pin RP14 U1TX
ByteIn = 123                    ' Load the variable
ByteOut = ICos(ByteIn)          ' Extract the integer Cosine of the value
HrsoutLn Dec ByteOut           ' Display the result
```

Note.

When implementing trigonometry, or other built in, functions within an expression, always wrap them in parenthesis, otherwise the parser may consider the extra operands as part of the trigonometry parameter and produce an incorrect result. For example:

```
MyAssignment = (ICos(MyVar1)) + MyVar2
```

Isqr

Syntax

Assignment Variable = **ISqr**(*Variable*)

Overview

Deduce the integer Square Root of an integer value

Operands

Assignment Variable can be any valid variable type.

Variable can be a constant, variable or expression that requires the Square Root extracted.

Example

```
Device = 24FJ64GA002
Declare Xtal = 16
Declare Hserial_Baud = 9600      ' USART1 baud rate
Declare Hrsout1_Pin = PORTB.14  ' Select the pin for TX with USART1

Dim ByteIn as Byte              ' Holds the value to Cos
Dim ByteOut as Byte             ' Holds the result of the Cos

RPOR7 = 3                       ' Make PPS Pin RP14 UITX

ByteIn = 123                    ' Load the variable
ByteOut = ISqr(ByteIn)          ' Extract the integer square root of the value
HrsoutLn Dec ByteOut            ' Display the result
```

Note.

When implementing trigonometry, or other built in, functions within an expression, always wrap them in parenthesis, otherwise the parser may consider the extra operands as part of the trigonometry parameter and produce an incorrect result. For example:

```
MyAssignment = (ISqr(MyVar1)) + MyVar2
```

Log

Syntax

Assignment Variable = **Log**(Variable)

Overview

Deduce the Natural Logarithm a 32-bit floating point value

Operands

Assignment Variable can be any valid variable type.

Variable can be a constant, variable or expression that requires the natural logarithm extracted.

Example

```
Device = 24FJ64GA002
Declare Xtal = 16
Declare Hserial_Baud = 9600      ' USART1 baud rate
Declare Hrsout1_Pin = PORTB.14  ' Select the pin for TX with USART1

Dim Floatin as Float           ' Holds the value to Log with
Dim Floatout as Float          ' Holds the result of the Log

RPOR7 = 3                      ' Make PPS Pin RP14 U1TX

Floatin = 1                    ' Load the variable
Floatout = Log(Floatin)        ' Extract the Log of the value
HrsoutLn Dec Floatout          ' Display the result
```

Notes.

Floating point trigonometry is rather memory hungry, so do not be surprised if a large chunk of the microcontroller's code memory is used with a single operator. This also means that floating point trigonometry is comparatively slow to operate.

When implementing trigonometry, or other built in, functions within an expression, always wrap them in parenthesis, otherwise the parser may consider the extra operands as part of the trigonometry parameter and produce an incorrect result. For example:

```
MyAssignment = (Log(MyVar1)) + MyVar2
```

dLog

Syntax

Assignment Variable = **dLog**(*Variable*)

Overview

Deduce the Natural Logarithm a 64-bit floating point value

Operands

Assignment Variable can be any valid variable type.

Variable can be a constant, variable or expression that requires the natural logarithm extracted.

Example

```
Device = 24FJ64GA002
Declare Xtal = 16
Declare Hserial_Baud = 9600      ' USART1 baud rate
Declare Hrsout1_Pin = PORTB.14  ' Select the pin for TX with USART1

Dim Doublein as Double         ' Holds the value to Log with
Dim Doubleout as Double        ' Holds the result of the Log

RPOR7 = 3                      ' Make PPS Pin RP14 U1TX

Doublein = 1                   ' Load the variable
Doubleout = dLog(Doublein)      ' Extract the Log of the value
HrsoutLn Dec Doubleout         ' Display the result
```

Notes.

64-bit floating point trigonometry is very memory hungry, so do not be surprised if a large chunk of the microcontroller's code memory is used with a single operator. This also means that floating point trigonometry is comparatively slow to operate.

The compiler uses the stack as temporary storage when performing 64-bit floating point library routines, therefore, it may be required to increase the stack size from the default 120 words to 200 words using the **Stack_Size** declare. If the program resets with a stack underflow/overflow exception when running, the stack size is insufficient and requires increasing.

When implementing trigonometry, or other built in, functions within an expression, always wrap them in parenthesis, otherwise the parser may consider the extra operands as part of the trigonometry parameter and produce an incorrect result. For example:

```
MyAssignment = (dLog(MyVar1)) + MyVar2
```

Log10

Syntax

Assignment Variable = **Log10**(*Variable*)

Overview

Deduce the Logarithm a 32-bit floating point value

Operands

Assignment Variable can be any valid variable type.

Variable can be a constant, variable or expression that requires the Logarithm extracted.

Example

```
Device = 24FJ64GA002
Declare Xtal = 16
Declare Hserial_Baud = 9600      ' USART1 baud rate
Declare Hrsout1_Pin = PORTB.14  ' Select the pin for TX with USART1

Dim Floatin as Float           ' Holds the value to Log10 with
Dim Floatout as Float          ' Holds the result of the Log10

RPOR7 = 3                      ' Make PPS Pin RP14 U1TX

Floatin = 1                    ' Load the variable
Floatout = Log10(Floatin)      ' Extract the Log10 of the value
HrsoutLn Dec Floatout         ' Display the result
```

Notes.

Floating point trigonometry is rather memory hungry, so do not be surprised if a large chunk of the microcontroller's code memory is used with a single operator. This also means that floating point trigonometry is comparatively slow to operate.

When implementing trigonometry, or other built in, functions within an expression, always wrap them in parenthesis, otherwise the parser may consider the extra operands as part of the trigonometry parameter and produce an incorrect result. For example:

```
MyAssignment = (Log10(MyVar1)) + MyVar2
```

dLog10

Syntax

Assignment Variable =dL(Variable)

Overview

Deduce the Logarithm a 64-bit floating point value

Operands

Assignment Variable can be any valid variable type.

Variable can be a constant, variable or expression that requires the Logarithm extracted.

Example

```
Device = 24FJ64GA002
Declare Xtal = 16
Declare Hserial_Baud = 9600      ' USART1 baud rate
Declare Hrsout1_Pin = PORTB.14  ' Select the pin for TX with USART1

Dim Doublein as Double          ' Holds the value to Log10 with
Dim Doubleout as Double         ' Holds the result of the Log10

RPOR7 = 3                       ' Make PPS Pin RP14 U1TX

Doublein = 1                     ' Load the variable
Doubleout = dLog10(Doublein)     ' Extract the Log10 of the value
HrsoutLn Dec Doubleout          ' Display the result
```

Notes.

64-bit floating point trigonometry is rather memory hungry, so do not be surprised if a large chunk of the microcontroller's code memory is used with a single operator. This also means that floating point trigonometry is comparatively slow to operate.

The compiler uses the stack as temporary storage when performing 64-bit floating point library routines, therefore, it may be required to increase the stack size from the default 120 words to 200 words using the **Stack_Size** declare. If the program resets with a stack underflow/overflow exception when running, the stack size is insufficient and requires increasing.

When implementing trigonometry, or other built in, functions within an expression, always wrap them in parenthesis, otherwise the parser may consider the extra operands as part of the trigonometry parameter and produce an incorrect result. For example:

```
MyAssignment = (dLog10(MyVar1)) + MyVar2
```

Modf

Syntax

Assignment Variable = **Modf** (*pVariable*, *pWhole*)

Overview

Split a 32-bit floating point value into fractional and whole parts.

Operands

Assignment Variable can be any valid variable type.

pVariable can be a floating point constant, variable or expression that will be split.

pWhole must be a 32-bit floating point variable that will hold the whole part of the split value.

Example

```
Device = 24FJ64GA002
Declare Xtal = 16
Declare Hserial_Baud = 9600           ' USART1 baud rate
Declare Hrsout1_Pin = PORTB.14       ' Select the pin for TX with USART1

Dim Floatin as Float
Dim Whole as Float                   ' Holds the whole part of the value
Dim Fraction as Float               ' Holds the fractional part of the value
Dim MyDword as Dword

RPOR7 = 3                            ' Make PPS Pin RP14 U1TX
Floatin = 3.14

Fraction = Modf(Floatin, Whole)      ' Split the value
MyDword = Whole                       ' Convert the whole part to an integer
HrsoutLn "Whole = " Dec MyDword
HrsoutLn "Fraction = ", Dec Fraction
```

Note.

When implementing trigonometry, or other built in, functions within an expression, always wrap them in parenthesis, otherwise the parser may consider the extra operands as part of the trigonometry parameter and produce an incorrect result. For example:

```
MyAssignment = (Modf(MyVar1)) + MyVar2
```

Modd

Syntax

Assignment Variable = **Modd** (*pVariable*, *pWhole*)

Overview

Split a 64-bit floating point value into fractional and whole parts.

Operands

Assignment Variable can be any valid variable type.

pVariable can be a floating point constant, variable or expression that will be split.

pWhole must be a 64-bit floating point variable that will hold the whole part of the split value.

Example

```
Device = 24FJ64GA002
Declare Xtal = 16
Declare Hserial_Baud = 9600           ' USART1 baud rate
Declare Hrsout1_Pin = PORTB.14       ' Select the pin for TX with USART1

Dim Doublein as Double
Dim Whole as Double                   ' Holds the whole part of the value
Dim Fraction as Double                ' Holds the fractional part of the value
Dim MyDword as Dword

RPOR7 = 3                             ' Make PPS Pin RP14 U1TX

Doublein = 3.14

Fraction = Modd(Doublein, Whole)       ' Split the value
MyDword = Whole                        ' Convert the whole part to an integer
HrsoutLn "Whole = " Dec MyDword
HrsoutLn "Fraction = ", Dec Fraction
```

Notes.

The compiler uses the stack as temporary storage when performing 64-bit floating point library routines, therefore, it may be required to increase the stack size from the default 120 words to 200 words using the **Stack_Size** declare. If the program resets with a stack underflow/overflow exception when running, the stack size is insufficient and requires increasing.

When implementing trigonometry, or other built in, functions within an expression, always wrap them in parenthesis, otherwise the parser may consider the extra operands as part of the trigonometry parameter and produce an incorrect result. For example:

```
MyAssignment = (Modd(MyVar1)) + MyVar2
```

Ncd

Priority encoder of a 16-bit or 32-bit value. Ncd takes a value, finds the highest bit containing a 1 and returns the bit position plus one (1 through 32). If no bit is set, the input value is 0. Ncd returns 0. Ncd is a fast way to get an answer to the question "what is the largest power of two that this value is greater than or equal to?" The answer that Ncd returns will be that power, plus one. Example: -

```
Device = 24FJ64GA002
Declare Xtal = 16
Declare Hserial_Baud = 9600      ' USART1 baud rate
Declare Hrsout1_Pin = PORTB.14  ' Select the pin for TX with USART1

Dim MyWord as Word
Dim MyResult as Word

RPOR7 = 3                        ' Make PPS Pin RP14 U1TX

MyWord= %00001101               ' Highest bit set is bit-3.
MyResult = Ncd MyWord
HrsoutLn Dec MyResult           ' Display the Ncd of MyWord1(4).
```

Ncd does not support **Float** or **Double** type variables.

Pow

Syntax

Assignment Variable = **Pow** (*Variable*, *Pow Variable*)

Overview

Computes 32-bit Floating point *Variable* to the power of *Pow Variable*.

Operands

Assignment Variable can be any valid variable type.

Variable can be a constant, variable or expression.

Pow Variable can be a constant, variable or expression.

Example

```
Device = 24FJ64GA002
Declare Xtal = 16
Declare Hserial_Baud = 9600      ' USART1 baud rate
Declare Hrsout1_Pin = PORTB.14  ' Select the pin for TX with USART1

Dim PowOf as Float
Dim Floatin as Float            ' Holds the value to Pow with
Dim Floatout as Float          ' Holds the result of the Pow

RPOR7 = 3                       ' Make PPS Pin RP14 U1TX

PowOf= 10
Floatin = 2                      ' Load the variable
Floatout = Pow(Floatin,PowOf)    ' Extract the Pow of the value
HrsoutLn Dec Floatout           ' Display the result
```

Notes.

Floating point trigonometry is rather memory hungry, so do not be surprised if a large chunk of the microcontroller's code memory is used with a single operator. This also means that floating point trigonometry is comparatively slow to operate.

Note.

When implementing trigonometry, or other built in, functions within an expression, always wrap them in parenthesis, otherwise the parser may consider the extra operands as part of the trigonometry parameter and produce an incorrect result. For example:

```
MyAssignment = (Pow(MyVar1)) + MyVar2
```

dPow

Syntax

Assignment Variable = **dPow** (*Variable*, *Pow Variable*)

Overview

Computes 64-bit Floating point *Variable* to the power of *Pow Variable*.

Operands

Assignment Variable can be any valid variable type.

Variable can be a constant, variable or expression.

Pow Variable can be a constant, variable or expression.

Example

```
Device = 24FJ64GA002
Declare Xtal = 16
Declare Hserial_Baud = 9600      ' USART1 baud rate
Declare Hrsout1_Pin = PORTB.14  ' Select the pin for TX with USART1

Dim PowOf as Double
Dim Doublein as Double          ' Holds the value to Pow with
Dim Doubleout as Double         ' Holds the result of the Pow

RPOR7 = 3                       ' Make PPS Pin RP14 U1TX

PowOf= 10
Doublein = 2                    ' Load the variable
Doubleout = Pow(Doublein,PowOf)  ' Extract the Pow of the value
HrsoutLn Dec Doubleout         ' Display the result
```

Notes.

64-bit floating point trigonometry is rather memory hungry, so do not be surprised if a large chunk of the microcontroller's code memory is used with a single operator. This also means that floating point trigonometry is comparatively slow to operate.

The compiler uses the stack as temporary storage when performing 64-bit floating point library routines, therefore, it may be required to increase the stack size from the default 120 words to 200 words using the **Stack_Size** declare. If the program resets with a stack underflow/overflow exception when running, the stack size is insufficient and requires increasing.

When implementing trigonometry, or other built in, functions within an expression, always wrap them in parenthesis, otherwise the parser may consider the extra operands as part of the trigonometry parameter and produce an incorrect result. For example:

```
MyAssignment = (dPow(MyVar1)) + MyVar2
```

Rev '@'

Reverses the order of the lowest bits in an integer value. The number of bits to be reversed is from 1 to 32. Its syntax is: -

```
Var1 = %10101100 @ 4 ' Sets Var1 to %10100011
```

OR

```
Dim MyDword as Dword  
' Sets MyDword to %10101010000000001111111110100011  
MyDword = %10101010000000001111111110101100 @ 4
```

Sin

Syntax

Assignment Variable = **Sin**(Variable)

Overview

Deduce the Sine of a 32-bit floating point value

Operands

Assignment Variable can be any valid variable type.

Variable can be a constant, variable or expression that requires the Sine extracted. The value expected and returned by **Sin** is in radians.

Example

```
Device = 24FJ64GA002
Declare Xtal = 16
Declare Hserial_Baud = 9600      ' USART1 baud rate
Declare Hrsout1_Pin = PORTB.14  ' Select the pin for TX with USART1

Dim Floatin as Float           ' Holds the value to Sin
Dim Floatout as Float         ' Holds the result of the Sin

RPOR7 = 3                      ' Make PPS Pin RP14 U1TX

Floatin = 123                  ' Load the variable
Floatout = Sin(Floatin)       ' Extract the Sin of the value
HrsoutLn Dec Floatout         ' Display the result
```

Notes.

Floating point trigonometry is rather memory hungry, so do not be surprised if a large chunk of the microcontroller's code memory is used with a single operator. This also means that floating point trigonometry is comparatively slow to operate.

When implementing trigonometry, or other built in, functions within an expression, always wrap them in parenthesis, otherwise the parser may consider the extra operands as part of the trigonometry parameter and produce an incorrect result. For example:

```
MyAssignment = (Sin(MyVar1)) + MyVar2
```

dSin

Syntax

Assignment Variable = **dSin**(*Variable*)

Overview

Deduce the Sine of a 64-bit floating point value

Operands

Assignment Variable can be any valid variable type.

Variable can be a constant, variable or expression that requires the Sine extracted. The value expected and returned by **dSin** is in radians.

Example

```
Device = 24FJ64GA002
Declare Xtal = 16
Declare Hserial_Baud = 9600      ' USART1 baud rate
Declare Hrsout1_Pin = PORTB.14  ' Select the pin for TX with USART1

Dim Doublein as Double          ' Holds the value to Sin
Dim Doubleout as Double         ' Holds the result of the Sin

RPOR7 = 3                       ' Make PPS Pin RP14 U1TX

Doublein = 123                  ' Load the variable
Doubleout = dSin(Doublein)      ' Extract the Sin of the value
HrsoutLn Dec Doubleout         ' Display the result
```

Notes.

64-bit floating point trigonometry is rather memory hungry, so do not be surprised if a large chunk of the microcontroller's code memory is used with a single operator. This also means that floating point trigonometry is comparatively slow to operate.

The compiler uses the stack as temporary storage when performing 64-bit floating point library routines, therefore, it may be required to increase the stack size from the default 120 words to 200 words using the **Stack_Size** declare. If the program resets with a stack underflow/overflow exception when running, the stack size is insufficient and requires increasing.

When implementing trigonometry, or other built in, functions within an expression, always wrap them in parenthesis, otherwise the parser may consider the extra operands as part of the trigonometry parameter and produce an incorrect result. For example:

```
MyAssignment = (dSin(MyVar1)) + MyVar2
```

Sqr

Syntax

Assignment Variable = **Sqr**(*Variable*)

Overview

Deduce the Square Root of a 32-bit floating point value

Operands

Assignment Variable can be any valid variable type.

Variable can be a constant, variable or expression that requires the Square Root extracted.

Example

```
Device = 24FJ64GA002
Declare Xtal = 16
Declare Hserial_Baud = 9600      ' USART1 baud rate
Declare Hrsout1_Pin = PORTB.14  ' Select the pin for TX with USART1

Dim Floatin as Float           ' Holds the value to Sqr
Dim Floatout as Float          ' Holds the result of the Sqr

RPOR7 = 3                      ' Make PPS Pin RP14 U1TX

Floatin = 600                  ' Load the variable
Floatout = Sqr(Floatin)        ' Extract the Sqr of the value
HrsoutLn Dec Floatout          ' Display the result
```

Notes.

Floating point trigonometry is rather memory hungry, so do not be surprised if a large chunk of the microcontroller's code memory is used with a single operator. This also means that floating point trigonometry is comparatively slow to operate.

When implementing trigonometry, or other built in, functions within an expression, always wrap them in parenthesis, otherwise the parser may consider the extra operands as part of the trigonometry parameter and produce an incorrect result. For example:

```
MyAssignment = (Sqr(MyVar1)) + MyVar2
```

dSqr

Syntax

Assignment Variable = **dSqr**(*Variable*)

Overview

Deduce the Square Root of a 64-bit floating point value

Operands

Assignment Variable can be any valid variable type.

Variable can be a constant, variable or expression that requires the Square Root extracted.

Example

```
Device = 24FJ64GA002
Declare Xtal = 16
Declare Hserial_Baud = 9600      ' USART1 baud rate
Declare Hrsout1_Pin = PORTB.14  ' Select the pin for TX with USART1

Dim Doublein as Double          ' Holds the value to Sqr
Dim Doubleout as Double         ' Holds the result of the Sqr

RPOR7 = 3                       ' Make PPS Pin RP14 U1TX

Doublein = 600                  ' Load the variable
Doubleout = dSqr(Doublein)       ' Extract the Sqr of the value
HrsoutLn Dec Doubleout         ' Display the result
```

Notes.

Floating point trigonometry is rather memory hungry, so do not be surprised if a large chunk of the microcontroller's code memory is used with a single operator. This also means that floating point trigonometry is comparatively slow to operate.

The compiler uses the stack as temporary storage when performing 64-bit floating point library routines, therefore, it may be required to increase the stack size from the default 120 words to 200 words using the **Stack_Size** declare. If the program resets with a stack underflow/overflow exception when running, the stack size is insufficient and requires increasing.

When implementing trigonometry, or other built in, functions within an expression, always wrap them in parenthesis, otherwise the parser may consider the extra operands as part of the trigonometry parameter and produce an incorrect result. For example:

```
MyAssignment = (dSqr(MyVar1)) + MyVar2
```

Tan

Syntax

Assignment Variable = **Tan**(*Variable*)

Overview

Deduce the Tangent of a 32-bit floating point value

Operands

Assignment Variable can be any valid variable type.

Variable can be a constant, variable or expression that requires the Tangent extracted. The value expected and returned by the floating point **Tan** is in radians.

Example

```
Device = 24FJ64GA002
Declare Xtal = 16
Declare Hserial_Baud = 9600      ' USART1 baud rate
Declare Hrsout1_Pin = PORTB.14  ' Select the pin for TX with USART1

Dim Floatin as Float           ' Holds the value to Tan
Dim Floatout as Float          ' Holds the result of the Tan

RPOR7 = 3                      ' Make PPS Pin RP14 U1TX

Floatin = 1                    ' Load the variable
Floatout = Tan(Floatin)        ' Extract the Tan of the value
HrsoutLn Dec Floatout          ' Display the result
```

Notes.

Floating point trigonometry is rather memory hungry, so do not be surprised if a large chunk of the microcontroller's code memory is used with a single operator. This also means that floating point trigonometry is comparatively slow to operate.

When implementing trigonometry, or other built in, functions within an expression, always wrap them in parenthesis, otherwise the parser may consider the extra operands as part of the trigonometry parameter and produce an incorrect result. For example:

```
MyAssignment = (Tan(MyVar1)) + MyVar2
```

dTan

Syntax

Assignment Variable = **dTan**(*Variable*)

Overview

Deduce the Tangent of a 64-bit floating point value

Operands

Assignment Variable can be any valid variable type.

Variable can be a constant, variable or expression that requires the Tangent extracted. The value expected and returned by the floating point **dTan** is in radians.

Example

```
Device = 24FJ64GA002
Declare Xtal = 16
Declare Hserial_Baud = 9600      ' USART1 baud rate
Declare Hrsout1_Pin = PORTB.14  ' Select the pin for TX with USART1

Dim Doublein as Double          ' Holds the value to Tan
Dim Doubleout as Double         ' Holds the result of the Tan

RPOR7 = 3                       ' Make PPS Pin RP14 U1TX

Doublein = 1                    ' Load the variable
Doubleout = dTan(Doublein)      ' Extract the Tan of the value
HrsoutLn Dec Doubleout        ' Display the result
```

Notes.

64-bit floating point trigonometry is very memory hungry, so do not be surprised if a large chunk of the microcontroller's code memory is used with a single operator. This also means that floating point trigonometry is comparatively slow to operate.

The compiler uses the stack as temporary storage when performing 64-bit floating point library routines, therefore, it may be required to increase the stack size from the default 120 words to 200 words using the **Stack_Size** declare. If the program resets with a stack underflow/overflow exception when running, the stack size is insufficient and requires increasing.

When implementing trigonometry, or other built in, functions within an expression, always wrap them in parenthesis, otherwise the parser may consider the extra operands as part of the trigonometry parameter and produce an incorrect result. For example:

```
MyAssignment = (dTan(MyVar1)) + MyVar2
```

Compiler Commands and Directives

Peripheral and Interfacing Commands

Adin	Read the on-board analogue to digital converter.
Bstart	Send a Start condition to the I ² C bus.
Bstop	Send a Stop condition to the I ² C bus.
Brestart	Send a Restart condition to the I ² C bus.
BusAck	Send an Acknowledge condition to the I ² C bus.
BusNack	Send an Not Acknowledge condition to the I ² C bus.
Busin	Read bytes from an I ² C device using a bit-bashed interface.
Busout	Write bytes to an I ² C device using a bit-bashed interface.
Button	Detect and debounce a key press.
ClearPin	Pull a pin low using a variable as the pin number.
Counter	Count the number of pulses occurring on a pin.
DTMFout	Produce a DTMF Touch Tone note.
Freqout	Generate one or two tones, of differing or the same frequencies.
GetPin	Read a pin from a port using a variable as the index
HbStart	Send a Start condition to the I ² C bus using the MSSP peripheral.
HbStop	Send a Stop condition to the I ² C bus using the MSSP peripheral.
HbRestart	Send a Restart condition to the I ² C bus using the MSSP peripheral.
HbusAck	Send an Ack condition to the I ² C bus using the MSSP peripheral.
HbusNack	Send a Not Ack condition to the I ² C bus using the MSSP peripheral.
Hbusin	Read from an I ² C device using the MSSP peripheral.
Hbusout	Write to an I ² C device using the MSSP peripheral.
High	Make a pin or port output high.
Hpwm	Generate a PWM signal using one of the the CCP peripherals.
I2Cin	Read bytes from an I ² C device with user definable SDA\SCL lines.
I2Cout	Write bytes to an I ² C device with user definable SDA\SCL lines.
Inkey	Scan a matrix keypad.
Input	Make pin an input.
Low	Make a pin or port output low.
Output	Make a pin an output.
Oread	Receive data from a device using the Dallas 1-wire protocol.
Owrite	Send data to a device using the Dallas 1-wire protocol.
Pot	Read a potentiometer on specified pin.
PulseIn	Measure the pulse width on a pin.
PulseOut	Generate a pulse from a pin.
Pwm	Output a Pulse Width Modulated pulse train to pin.
RCin	Measure a pulse width on a pin.
Servo	Control a servo motor.
SetPin	Set a pin high using a variable as the pin number.
Shin	Synchronous serial input.
Shout	Synchronous serial output.
Sound	Generate a tone or white-noise on a specified pin.
Toggle	Reverse the state of a port's bit.
Touch_Active	Detect if the touch screen is being touched.
Touch_Read	Read the X and Y coordinates from the touch screen
Touch_HotSpot	Detect a touch within a user defined window on the touch screen

LCD Commands

Box	Draw a square on a graphic LCD.
Circle	Draw a circle on a graphic LCD.
Cls	Clear an LCD.
Cursor	Position the cursor on the LCD.
LCDread	Read a single byte from a Graphic LCD.
LCDwrite	Write bytes to a Graphic LCD.
Line	Draw a line in any direction on a graphic LCD.
LineTo	Draw a straight line in any direction on a graphic LCD, starting from the previous Line command's end position.
Pixel	Read a single pixel from a Graphic LCD.
Plot	Set a single pixel on a Graphic LCD.
Print	Display characters on an LCD.
Toshiba_Command	Send a command to a Toshiba T6963 graphic LCD.
Toshiba_UDG	Create User Defined Graphics for Toshiba T6963 graphic LCD.
UnPlot	Clear a single pixel on a Graphic LCD.

Async Serial Commands

Hrsin	Receive data from the serial port on devices that contain a USART.
Hrsout	Transmit data from the serial port on devices that contain a USART.
HrsoutLn	Transmit data from the serial port on devices that contain a USART and transmit a terminator value or values.
Hserin	Receive data from the serial port on devices that contain a USART.
Hserout	Transmit data from the serial port on devices that contain a USART.
HseroutLn	Transmit data from the serial port on devices that contain a USART and transmit a terminator value or values.
Hrsin2	Same as Hrsin but using a 2nd USART if available.
Hrsout2	Same as Hrsout but using a 2nd USART if available.
Hrsout2Ln	Same as HrsoutLn but using a 2nd USART if available.
Hserin2	Same as Hserin but using a 2nd USART if available.
Hserout2	Same as Hserout but using a 2nd USART if available.
Hserout2Ln	Same as HseroutLn but using a 2nd USART if available.
Hrsin3	Same as Hrsin but using a 3rd USART if available.
Hrsout3	Same as Hrsout but using a 3rd USART if available.
Hrsout3Ln	Same as HrsoutLn but using a 3rd USART if available.
Hserin3	Same as Hserin but using a 3rd USART if available.
Hserout3	Same as Hserout but using a 3rd USART if available.
Hserout3Ln	Same as HseroutLn but using a 3rd USART if available.
Hrsin4	Same as Hrsin but using a 4th USART if available.
Hrsout4	Same as Hrsout but using a 4th USART if available.
Hrsout4Ln	Same as HrsoutLn but using a 4th USART if available.
Hserin4	Same as Hserin but using a 4th USART if available.
Hserout4	Same as Hserout but using a 4th USART if available.
Hserout4Ln	Same as HseroutLn but using a 4th USART if available.
Rsin	Asynchronous serial input from a fixed pin and baud rate.
Rout	Asynchronous serial output to a fixed pin and baud rate.
RoutLn	Asynchronous serial output to a fixed pin and baud rate, and transmit a terminator value or values.
Serin	Receive asynchronous serial data (i.e. RS232 data).
Serout	Transmit asynchronous serial data (i.e. RS232 data).

Comparison and Loop Commands

Branch	Computed GoTo (equiv. to On..GoTo).
BranchL	Branch out of page (long Branch).
Break	Exit a loop prematurely.
Continue	Cause the next iteration of the enclosing loop to begin.
Do...Loop	Execute a block of instructions until a condition is true.
For...to...Next...Step	Repeatedly execute statements.
If..Then..Elseif..Else..EndIf	Conditionally execute statements.
On Gosub	Call a Subroutine based on an Index value.
On GoTo	Jump to an address in code memory based on an Index value. (Primarily for smaller devices)
On GotoL	Jump to an address in code memory based on an Index value. (Primarily for larger devices)
Repeat...Until	Execute a block of instructions until a condition is true.
Select..Case..EndSelect	Conditionally run blocks of code.
While...Wend	Execute statements while condition is true.

General BASIC Commands

Call	Call an assembly language subroutine.
Clear	Place a variable or bit in a low state, or clear all RAM area.
ClearBit	Clear a bit of a port or variable, using a variable index.
Dec	Decrement a variable.
DelayMs	Delay (1 millisecond resolution).
DelayUs	Delay (1 microsecond resolution).
DelayCs	Delay (1 clock cycle resolution).
Dig	Return the value of a decimal digit.
GetBit	Examine a bit of a port or variable, using a variable index.
Gosub	Call a BASIC subroutine at a specified label.
GoTo	Continue execution at a specified label.
Inc	Increment a variable.
LoadBit	Set or Clear a bit of a port or variable, using a variable index.
Ptr8, Ptr16, Ptr32, Ptr64	Indirectly read or write RAM using a variable to hold the address.
Random	Generate a pseudo-random number.
Return	Continue at the statement following the last Gosub .
Rol	Bitwise rotate a variable left with or without the microcontroller's Carry flag.
Ror	Bitwise rotate a variable right with or without the microcontroller's Carry flag.
Seed	Seed the random number generator, to obtain a more random result.
Set	Place a variable or bit in a high state.
SetBit	Set a bit of a port or variable, using a variable index.
Stop	Stop program execution.
Swap	Exchange the values of two variables.
End	Stop execution of the BASIC program.

RAM String Variable Commands

Left\$	Extract n amount of characters from the left of a String.
Mid\$	Extract characters from a String beginning at n characters from the left.
Right\$	Extract n amount of characters from the right of a String.
Str	Load a Byte array with values.
Strn	Create a null terminated byte array.
Str\$	Convert the contents of a variable to a null terminated String.
ToLower	Convert the characters in a String to lower case.
ToUpper	Convert the characters in a String to upper case.
Val	Convert a null terminated String to an integer value.

Non-Volatile Data Commands

cPtr8, cPtr16, cPtr32, cPtr64	Indirectly read flash memory using a variable as the address.
Cdata	Place information into flash memory. For access by CreadX .
Cread8, Cread16, Cread32, Cread64	Read a value from a code memory table.
Edata	Define initial contents of on-board eeprom.
Eread	Read a value from on-board eeprom.
Ewrite	Write a value to on-board eeprom.
LookDown	Search a constant lookdown table for a value.
LookDownL	Search constant or variable lookdown table for a value.
LookUp	Fetch a constant value from a lookup table.
LookUpL	Fetch a constant or variable value from lookup table.

Directives

AddressOf	Locate the address of a variable or label.
Asm-EndAsm	Insert assembly language code section.
Config	Set or Reset programming fuse configurations.
Declare	Adjust library routine parameters.
Device	Choose the type of PIC24 [®] or dsPIC33 [®] microcontroller to compile for.
Dim	Create a variable.
Include	Load a BASIC file into the source code.
ISR_Start...ISR_End	Define an interrupt handler block of code.
Symbol	Create an alias to a constant, port, pin, or register.

Adin

Syntax

Assignment Variable = **Adin** ANx pin number

Overview

Read the value from the on-board Analogue to Digital Converter.

Parameters

Assignment Variable is a user defined variable that holds the result of the ADC.

ANx pin number can be a constant, variable or expression. It holds the ADC number from MUXA of the device in use.

Example

```
' Read the value from AN0 of the ADC and serially transmit the result.
Device = 24FJ64GA002
Declare Xtal = 32

Declare Adin_Tad = cFRC          ' RC oscillator chosen
Declare Adin_Stime = 10         ' Allow 10us sample time

Declare Hserial_Baud = 9600     ' USART1 baud rate
Declare Hrsout1_Pin = PORTB.14 ' Pin to be used for TX with USART1

Dim ADC_Result as Word         ' Create a word variable

CLKDIV = 0                     ' CPU peripheral clock ratio set to 1:1
Write_OSCCONH(%00010000)      ' Enable PLL
RPOR7 = 3                      ' Make PPS Pin RP14 U1TX
AD1CON2 = 0                    ' AVdd, AVss, MUXA only
AD1PCFGbits_PCFG0 = 0         ' Analogue input on pin AN0

Do                               ' Create an infinite loop
  ADC_Result = Adin 0          ' Place the conversion into variable ADC_Result
  HrsoutLn Dec ADC_Result     ' Transmit the decimal ASCII result
  DelayMs 100                 ' Wait for 100 milliseconds
Loop                             ' Do it forever
'
' For internal oscillator with PLL
'
Config Config1 = JTAGEN_OFF, GCP_OFF, GWRP_OFF, BKBUG_OFF, COE_OFF, _
                ICS_PGx1, FWDTEN_OFF, WINDIS_OFF, FWPSA_PR128, WDTPOST_PS256
Config Config2 = IOL1WAY_OFF, COE_OFF, IESO_OFF, FNOSC_FRCPLL, _
                FCKSM_CSDCMD, OSCIOFNC_ON, POSCMOD_NONE
```

Adin Declares

There are two **Declare** directives for use with **Adin**. These are: -

Declare Adin_Tad c1_FOSC, c2_FOSC, c4_FOSC, c8_FOSC, c16_FOSC, c32_FOSC, c64_FOSC, or cFRC.

Sets the ADC's clock source.

All compatible devices have multiple options for the clock source used by the ADC peripheral. c1_FOSC, c2_FOSC, c4_FOSC, c8_FOSC, c16_FOSC, c32_FOSC, and c64_FOSC are ratios of the external oscillator, while FRC is the device's internal RC oscillator.

Care must be used when issuing this **Declare**, as the wrong type of clock source may result in poor accuracy, or no conversion at all. If in doubt use FRC which will produce a slight reduction in accuracy and conversion speed, but is guaranteed to work first time, every time. FRC is the default setting if the **Declare** is not issued in the BASIC listing.

Declare Adin_Stime 0 to 65535 microseconds (us).

Allows the internal capacitors to fully charge before a sample is taken. This may be a value from 0 to 65535 microseconds (us).

A value too small may result in a reduction of resolution. While too large a value will result in poor conversion speeds without any extra resolution being attained.

A typical value for **Adin_Stime** is 2 to 100. This allows adequate charge time without losing too much conversion speed. But experimentation will produce the right value for your particular requirement. The default value if the **Declare** is not used in the BASIC listing is 50.

Notes.

Before the **Adin** command may be used, the appropriate pin must be configured as an analogue input. Refer to the datasheet of the specific device being used for more information on the SFRs involved.

If multiple conversions are being implemented, then a small delay should be used after the **Adin** command. This allows the ADC's internal capacitors to discharge fully: -

```
Do                               ' Create an infinite loop
  MyWord = Adin 0                 ' Place the conversion into variable MyWord
  DelayUs 4                       ' Wait for 4us
Loop                              ' Read the ADC forever
```

See also : Rcin, Pot.

Asm..EndAsm

Syntax

Asm

assembler mnemonics

EndAsm

or

@ *assembler mnemonic*

Overview

Incorporate in-line assembler in the BASIC code. The mnemonics are passed directly to the assembler without the compiler interfering in any way. This allows a great deal of flexibility that cannot always be achieved using BASIC commands alone.

The compiler also allows simple assembler mnemonics to be used within the BASIC program without wrapping them in **Asm-EndAsm**.

Box

Syntax

Box *Pixel Colour, Xpos Start, Ypos Start, Size*

Overview

Draw a square on a graphic LCD.

Parameters

Pixel Colour may be a constant or variable that determines if the square will set or clear the pixels. A value of 1 will set the pixels and draw a square, while a value of 0 will clear any pixels and erase a square. If using a colour graphic LCD, this parameter holds the 16-bit colour of the pixel.

Xpos Start may be a constant or variable that holds the X position for the centre of the square. Can be a value from 0 to 65535.

Ypos Start may be a constant or variable that holds the Y position for the centre of the square. Can be a value from 0 to 65535.

Size may be a constant or variable that holds the size of the square (in pixels). Can be a value from 0 to 65535.

KS0108 graphic LCD example

```
' Draw a square at position 63,32 with a size of 20 pixels
' on a KS0108 graphic LCD
Device = 24FJ64GA002
Declare Xtal = 32

Declare LCD_Type = KS0108           ' Setup for a KS0108 graphic LCD
Declare LCD_DTPort = PORTB.Byte0    ' Use the first 8-bits of PORTB
Declare LCD_CS1Pin = PORTB.8
Declare LCD_CS2Pin = PORTB.9
Declare LCD_ENPin = PORTB.10
Declare LCD_RSPin = PORTB.11
Declare LCD_RWPin = PORTB.12

Dim Xpos as Byte
Dim Ypos as Byte
Dim Size as Byte
Dim SetClr as Byte
CLKDIV = 0                          ' CPU peripheral clock ratio set to 1:1
Write_OSCCONH(%00010000)           ' Enable PLL

DelayMs 100                          ' Wait for things to stabilise
Cls                                    ' Clear the LCD
Xpos = 63
Ypos = 32
Size = 20
SetClr = 1
Box SetClr, Xpos, Ypos, Radius
,
' Config fuses for internal oscillator with PLL
,
Config Config1 = JTAGEN_OFF, GCP_OFF, GWRP_OFF, BKBUG_OFF, COE_OFF, _
                ICS_PGx1, FWDTEN_OFF, WINDIS_OFF, FWPSA_PR128, WDTPOST_PS256
Config Config2 = IOL1WAY_OFF, COE_OFF, IESO_OFF, FNOSC_FRCPLL, _
                FCKSM_CSDCMD, OSCIOFNC_ON, POSCMOD_NONE
```

ILI9320 colour graphic LCD example

```
' Demonstrate the box command with a colour LCD
,
Device = 24EP128MC202
Declare Xtal = 140.03
,
' Setup the Pins used by the ILI9320 graphic LCD
,
Declare LCD_DTPort = PORTB.Byte0      ' Use the first 8-bits of PORTB
Declare LCD_CSPin = PORTB.8          ' Connect to the LCD's CS pin
Declare LCD_RDPin = PORTB.9          ' Connect to the LCD's RD pin
Declare LCD_RSPin = PORTB.10         ' Connect to the LCD's RS pin
Declare LCD_WRPin = PORTA.3          ' Connect to the LCD's WR pin

Include "ILI9320.inc"                ' Load the ILI9320 routines into the program

Dim wRadius As Word                  ' Create a variable for the circle's radius

-----
Main:
' Configure the internal Oscillator to operate the device at 140.03MHz
,
PLL_Setup(76, 2, 2, $0300)

Cls clYellow                          ' Clear the LCD with the colour yellow
For wRadius = 0 To 319
    Box clBrightCyan, 120, 160, wRadius ' Draw a series of squares
Next
-----
' Configure for internal 7.37MHz oscillator with PLL
' OSC pins are general purpose I/O
,
Config FGS = GWRP_OFF, GCP_OFF
Config FOSCSEL = FNOSC_FRCPLL, IESO_ON, PWMLOCK_OFF
Config FOSC = POSCMD_NONE, OSCIOFNC_ON, IOL1WAY_OFF, FCKSM_CSDCMD
Config FWDT = WDTPOST_PS256, WINDIS_OFF, PLLKEN_ON, FWDTEN_OFF
Config FPOR = ALTI2C1_ON, ALTI2C2_OFF
Config FICD = ICS_PGD1, JTAGEN_OFF
```

Notes.

Because of the aspect ratio of the pixels on the KS0108 graphic LCD (approx 1.5 times higher than wide) the circle will appear elongated.

With an ILI9320 colour graphic LCD, the colour is a 16-bit value formatted in RGB565, where the upper 5-bits represent the red content, the middle 6-bits represent the green content, and the lower 5-bits represent the blue content. As illustrated below:

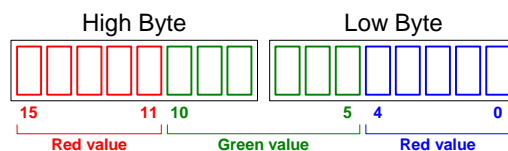

For convenience, there are several colours defined within the ILI9320.inc file. These are:

```
clBlack  
clBrightBlue  
clBrightGreen  
clBrightCyan  
clBrightRed  
clBrightMagenta  
clBrightYellow  
clBlue  
clGreen  
clCyan  
clRed  
clMagenta  
clBrown  
clLightGray  
clDarkGray  
clLightBlue  
clLightGreen  
clLightCyan  
clLightRed  
clLightMagenta  
clYellow  
clWhite
```

More constant values for colours can be added by the user if required.

See Also : **Circle, Line, LineTo, Plot, UnPlot.**

Branch

Syntax

Branch *Index*, [*Label1* {...*Labeln* }]

Overview

Cause the program to jump to different locations based on a variable index, where the destination is within 32768 bytes from the source.

Parameters

Index is a constant, variable, or expression, that specifies the address to branch to.

Label1,...**Labeln** are valid labels that specify where to branch to. A maximum of 65536 labels may be placed between the square brackets.

Example

```
Device = 24FJ64GA002
Declare Xtal = 32

Dim Index as Byte

CLKDIV = 0           ' CPU peripheral clock ratio set to 1:1
Write_OSCCONH(%00010000) ' Enable PLL

Start:
  Index = 2           ' Assign Index a value of 2
  Branch Index,[Lab_0, Lab_1, Lab_2] ' Jump to Lab_2 because Index = 2
Lab_0:
  Index = 2           ' Index now equals 2
  GoTo Start
Lab_1:
  Index = 0           ' Index now equals 0
  GoTo Start
Lab_2:
  Index = 1           ' Index now equals 1
  GoTo Start
,
' Config fuses for internal oscillator with PLL
,
Config Config1 = JTAGEN_OFF, GCP_OFF, GWRP_OFF, BKBUG_OFF, COE_OFF, _
                ICS_PGx1, FWDTEN_OFF, WINDIS_OFF, FWPSA_PR128, WDTPOST_PS256
Config Config2 = IOL1WAY_OFF, COE_OFF, IESO_OFF, FNOSC_FRCPLL, _
                FCKSM_CSDCMD, OSCIOFNC_ON, POSCMOD_NONE
```

The above example we first assign the index variable a value of 2, then we define our labels. Since the first position is considered 0 and the variable index equals 2 the **Branch** command will cause the program to jump to the third label in the brackets [Lab_2].

Notes.

Branch operates the same as On x GoTo. It's useful when you want to organise a structure such as: -

```
If Var1 = 0 Then GoTo Lab_0 ' Var1 =0: go to label "Lab_0"
If Var1 = 1 Then GoTo Lab_1 ' Var1 =1: go to label "Lab_1"
If Var1 = 2 Then GoTo Lab_2 ' Var1 =2: go to label "Lab_2"
```

You can use **Branch** to organise this into a single statement: -

```
Branch Var1, [Lab_0, Lab_1, Lab_2]
```

This works exactly the same as the above **If...Then** example. If the value is not in range (in this case if Var1 is greater than 2), **Branch** does nothing. The program continues with the next instruction..

The **Branch** command is primarily for use with devices that have less code memory. If larger devices are used and you suspect that the branch label will be over the 32768 boundary, use the **BranchL** command instead.

BranchL

Syntax

BranchL *Index*, [*Label1* {...*Labeln*}]

Overview

Cause the program to jump to different locations based on a variable index.

Parameters

Index is a constant, variable, or expression, that specifies the address to branch to.

Label1,...**Labeln** are valid labels that specify where to branch to. A maximum of 65536 labels may be placed between the square brackets.

Example

```
Device = 24FJ64GA002
Declare Xtal = 32

Dim Index as Byte

CLKDIV = 0           ' CPU peripheral clock ratio set to 1:1
Write_OSCCONH(%00010000) ' Enable PLL

Start:
  Index = 2           ' Assign Index a value of 2
  ' Jump to label 2 (Label_2) because Index = 2
  BranchL Index,[Label_0, Label_1, Label_2]
Label_0:
  Index = 2           ' Index now equals 2
  GoTo Start
Label_1:
  Index = 0           ' Index now equals 0
  GoTo Start
Label_2:
  Index = 1           ' Index now equals 1
  GoTo Start
'
' Config fuses for internal oscillator with PLL
'
Config Config1 = JTAGEN_OFF, GCP_OFF, GWRP_OFF, BKBUG_OFF, COE_OFF, _
                ICS_PGx1, FWDTEN_OFF, WINDIS_OFF, FWPSA_PR128, WDTPOST_PS256
Config Config2 = IOL1WAY_OFF, COE_OFF, IESO_OFF, FNOSC_FRCPLL, _
                FCKSM_CSDCMD, OSCIOFNC_ON, POSCMOD_NONE
```

The above example we first assign the index variable a value of 2, then we define our labels. Since the first position is considered 0 and the variable index equals 2 the **BranchL** command will cause the program to jump to the third label in the brackets [Label_2].

See also : [Branch](#)

Break

Syntax Break

Overview

Exit a **For...Next**, **While...Wend** or **Repeat...Until** loop prematurely.

Example 1

```
' Break out of a For-Next loop when the count reaches 10

Device = 24FJ64GA002
Declare Xtal = 32
Declare Hserial_Baud = 9600      ' USART1 baud rate
Declare Hrsout1_Pin = PORTB.14  ' Select the pin for TX with USART1

Dim MyByte as Byte

CLKDIV = 0                        ' CPU peripheral clock ratio set to 1:1
Write_OSCCONH(%00010000)        ' Enable PLL
RPOR7 = 3                        ' Make PPS Pin RP14 U1TX
For MyByte = 0 to 39
    HrsoutLn Dec MyByte          ' Display revolutions on the serial terminal
    If MyByte = 10 Then Break   ' Break out of the loop when MyByte = 10
    DelayMs 200                 ' Delay so we can see what's happening
Next                             ' Close the For-Next loop
HrsoutLn "Exited At ", Dec MyByte ' Display value when loop was broken
,
' Config fuses for internal oscillator with PLL
,

Config Config1 = JTAGEN_OFF, GCP_OFF, GWRP_OFF, BKBUG_OFF, COE_OFF, _
                ICS_PGx1, FWDTEN_OFF, WINDIS_OFF, FWPSA_PR128, WDTPOST_PS256
Config Config2 = IOL1WAY_OFF, COE_OFF, IESO_OFF, FNOSC_FRCPLL, _
                FCKSM_CSDCMD, OSCIOFNC_ON, POSCMOD_NONE
```

Example 2

```
' Break out of a Repeat-Until loop when the count reaches 10

Device = 24FJ64GA002
Declare Xtal = 32
Declare Hserial_Baud = 9600      ' USART1 baud rate
Declare Hrsout1_Pin = PORTB.14  ' Select the pin for TX with USART1

Dim MyByte as Byte

CLKDIV = 0                        ' CPU peripheral clock ratio set to 1:1
Write_OSCCONH(%00010000)        ' Enable PLL
RPOR7 = 3                        ' Make PPS Pin RP14 U1TX
MyByte = 0
Repeat
    HrsoutLn Dec MyByte          ' Display revolutions on the serial terminal
    If MyByte = 10 Then Break   ' Break out of the loop when MyByte = 10
    DelayMs 200                 ' Delay so we can see what's happening
    Inc MyByte
Until MyByte > 39               ' Close the loop after 40 revolutions
HrsoutLn "Exited At ", Dec MyByte ' Display value when loop was broken
,
' Config fuses for internal oscillator with PLL
,

Config Config1 = JTAGEN_OFF, GCP_OFF, GWRP_OFF, BKBUG_OFF, COE_OFF, _
                ICS_PGx1, FWDTEN_OFF, WINDIS_OFF, FWPSA_PR128, WDTPOST_PS256
Config Config2 = IOL1WAY_OFF, COE_OFF, IESO_OFF, FNOSC_FRCPLL, _
                FCKSM_CSDCMD, OSCIOFNC_ON, POSCMOD_NONE
```

Example 3

```
' Break out of a While-Wend loop when the count reaches 10

Device = 24FJ64GA002
Declare Xtal = 32
Declare Hserial_Baud = 9600 ' USART1 baud rate
Declare Hrsout1_Pin = PORTB.14 ' Select the pin for TX with USART1

Dim MyByte as Byte

CLKDIV = 0 ' CPU peripheral clock ratio set to 1:1
Write_OSCCONH(%00010000) ' Enable PLL
RPOR7 = 3 ' Make PPS Pin RP14 U1TX

MyByte = 0
While MyByte < 40 ' Create a loop of 40 iterations
    HrsoutLn Dec MyByte ' Display iterations on the serial terminal
    If MyByte = 10 Then Break ' Break out of the loop when MyByte = 10
    DelayMs 200 ' Delay so we can see what's happening
    Inc MyByte
Wend ' Close the loop
HrsoutLn "Exited At ", Dec MyByte ' Display value when loop was broken
'
' Config fuses for internal oscillator with PLL
'
Config Config1 = JTAGEN_OFF, GCP_OFF, GWRP_OFF, BKBUG_OFF, COE_OFF, _
                ICS_PGx1, FWDTEN_OFF, WINDIS_OFF, FWPSA_PR128, WDTPOST_PS256
Config Config2 = IOLLWAY_OFF, COE_OFF, IESO_OFF, FNOSC_FRCPLL, _
                FCKSM_CSDCMD, OSCIOFNC_ON, POSCMOD_NONE
```

Notes.

The **Break** command is similar to a **GoTo** but operates internally. When the **Break** command is encountered, the compiler will force a jump to the loop's internal exit label.

If the **Break** command is used outside of a **For...Next**, **Repeat...Until**, **While...Wend** or **Do...Loop** condition, an error will be produced.

See also : **Continue**, **For...Next**, **While...Wend**, **Repeat...Until**, **Do...Loop**.

Bstart

Syntax

Bstart

Overview

Send a **Start** condition to the I²C bus.

Notes.

Because of the subtleties involved in interfacing to some I²C devices, the compiler's standard **Busin**, and **Busout** commands were found lacking somewhat. Therefore, individual pieces of the I²C protocol may be used in association with the new structure of **Busin**, and **Busout**. See relevant sections for more information.

Example

```
' Interface to a 24LC32 serial eeprom
Device = 24FJ64GA002
Declare Xtal = 8
Declare Hserial_Baud = 9600      ' USART1 baud rate
Declare Hrsout1_Pin = PORTB.14   ' Select the pin for TX with USART1
Declare SCL_Pin = PORTB.3        ' Select the pin for I2C SCL
Declare SDA_Pin = PORTB.4        ' Select the pin for I2C SDA

Dim Loop as Byte
Dim MyString as String * 20
RPOR7 = 3                        ' Make PPS Pin RP14 U1TX
,
' Transmit bytes to the I2C bus
,
  Bstart                          ' Send a Start condition
  Busout %10100000                ' Target an eeprom, and send a Write command
  Busout 0                         ' Send the High Byte of the address
  Busout 0                         ' Send the Low Byte of the address
  For Loop = 48 to 57              ' Create a loop containing ASCII 0 to 9
    Busout Loop                   ' Send the value of Loop to the eeprom
  Next                             ' Close the loop
  Bstop                           ' Send a Stop condition
  DelayMs 5                       ' Wait for data to be entered into eeprom matrix
,
' Receive bytes from the I2C bus
,
  Clear MyString                  ' Clear the string before we start
  Bstart                          ' Send a Start condition
  Busout %10100000                ' Target an eeprom, and send a Write command
  Busout 0                         ' Send the High Byte of the address
  Busout 0                         ' Send the Low Byte of the address
  Brestart                         ' Send a Restart condition
  Busout %10100001                ' Target an eeprom, and send a Read command
  For Loop = 0 to 9               ' Create a loop
    MyString[Loop] = Busin        ' Load a string with bytes received
    If Loop = 9 Then Bstop : Else : BusAck ' Ack or Stop ?
  Next                             ' Close the loop
  Hrsout MyString , 13           ' Display the String
```

See also: **Bstop, Brestart, BusAck, Busin, Busout, HbStart, HbRestart, HbusAck, Hbusin, Hbusout.**

Bstop

Syntax
Bstop

Overview

Send a **Stop** condition to the I²C bus.

Brestart

Syntax
Brestart

Overview

Send a **Restart** condition to the I²C bus.

BusAck

Syntax
BusAck

Overview

Send an **Acknowledge** condition to the I²C bus.

BusNack

Syntax
BusNack

Overview

Send a **Not Acknowledge** condition to the I²C bus.

See also: **Bstop, Bstart, Brestart, Busin, Busout, HbStart, HbRestart, HbusAck, Hbusin, Hbusout.**

Busin

Syntax

Assignment Variable = **Busin** *Control*, { *Address* }

or

Variable = **Busin**

or

Busin *Control*, { *Address* }, [*Variable* {, *Variable*...}]

or

Busin *Variable*

Overview

Receives a value from the I²C bus, and places it into *variable/s*. If versions *two* or *four* (see above) are used, then No Acknowledge, or Stop is sent after the data. Versions *one* and *three* first send the *control* and optional *address* out of the clock pin (SCL), and data pin (SDA).

Parameters

Assignment Variable is a user defined variable or constant.

Control may be a constant value or a **Byte** sized variable expression.

Address may be a constant value or a variable expression.

The four variations of the **Busin** command may be used in the same BASIC program. The *second* and *fourth* types are useful for simply receiving a single byte from the bus, and must be used in conjunction with one of the low level commands. i.e. **Bstart**, **Brestart**, **BusAck**, or **Bstop**. The *first*, and *third* types may be used to receive several values and designate each to a separate variable, or variable type.

The **Busin** command is a software implementation (bit-bashed) and operates as an I²C master, without using the microcontroller's MSSP peripheral, and may be used to interface with any device that complies with the 2-wire I²C protocol.

The most significant 7-bits of *control* byte contain the control code and the slave address of the device being interfaced with. Bit-0 is the flag that indicates whether a read or write command is being implemented.

For example, if we were interfacing to an external eeprom such as the 24LC32, the control code would be %10100001 or \$A1. The most significant 4-bits (1010) are the eeprom's unique slave address. Bits 1 to 3 reflect the three address pins of the eeprom. And bit-0 is set to signify that we wish to read from the eeprom. Note that this bit is automatically set by the **Busin** command, regardless of its initial setting.

Example

```
' Receive a byte from the I2C bus and place it into variable MyByte.
Device = 24FJ64GA002
Declare Xtal = 8
Declare SCL_Pin = PORTB.3      ' Select the pin for I2C SCL
Declare SDA_Pin = PORTB.4      ' Select the pin for I2C SDA

Dim Loop as Byte
Dim MyString as String * 20
Dim MyByte as Byte             ' We'll only read 8-bits
Dim Address as Word            ' 16-bit address required
Symbol Control %10100001      ' Target an eeprom

Address = 20                    ' Read the value at address 20
MyByte = Busin Control, Address ' Read the byte from the eeprom
```

or

```
Busin Control, Address, [ MyByte ] ' Read the byte from the eeprom
```

Address, is an optional parameter that may be an 8-bit or 16-bit value. If a variable is used in this position, the size of *address* is dictated by the size of the variable used (**Byte**, **Word**, or **Dword**). In the case of the previous eeprom interfacing, the 24LC32 eeprom requires a 16-bit address. While the smaller types require an 8-bit address. Make sure you assign the right size address for the device interfaced with, or you may not achieve the results you intended.

The value received from the bus depends on the size of the variables used, except for variation three, which only receives a **Byte** (8-bits). For example: -

```
Dim MyWord as Word             ' Create a Word size variable
MyWord = Busin Control, Address
```

Will receive a 16-bit value from the bus. While: -

```
Dim MyByte as Byte            ' Create a Byte size variable
MyByte = Busin Control, Address
```

Will receive an 8-bit value from the bus.

Using the *third* variation of the **Busin** command allows differing variable assignments. For example: -

```
Dim MyByte as Byte
Dim MyWord as Word
Busin Control, Address, [MyByte, MyWord]
```

Will receive two values from the bus, the first being an 8-bit value dictated by the size of variable *Var1* which has been declared as a byte. And a 16-bit value, this time dictated by the size of the variable *MyWord* which has been declared as a word. Of course, **Bit** type variables may also be used, but in most cases these are not of any practical use as they still take up a byte within the eeprom.

The *second* and *fourth* variations allow all the subtleties of the I²C protocol to be exploited, as each operation may be broken down into its constituent parts. It is advisable to refer to the datasheet of the device being interfaced to fully understand its requirements. See section on **Bstart**, **Brestart**, **BusAck**, or **Bstop**, for example code.

Declares

See **Busout** for declare explanations.

Notes.

When the **Busout** command is used, the appropriate SDA and SCL Port and Pin are automatically setup as inputs, and outputs.

Because the I²C protocol calls for an *open-collector* interface, pull-up resistors are required on both the SDA and SCL lines. Values of 1K Ω to 4.7K Ω will suffice.

You may imagine that it's limiting having a fixed set of pins for the I²C interface, but you should remember that several different devices may be attached to a single bus, each having a unique slave address. Which means there is usually no need to use up more than two pins on the microcontroller in order to interface to many devices.

Str modifier with Busin

Using the **Str** modifier allows variations *three* and *four* of the **Busin** command to transfer the bytes received from the I²C bus directly into a byte array. If the amount of received characters is not enough to fill the entire array, then a formatter may be placed after the array's name, which will only receive characters until the specified length is reached. An example of each is shown below: -

```
Device = 24FJ64GA002
Declare Xtal = 8
Declare SCL_Pin = PORTB.3      ' Select the pin for I2C SCL
Declare SDA_Pin = PORTB.4      ' Select the pin for I2C SDA

Dim Array[10] as Byte          ' Create an array of 10 bytes
Dim Address as Byte            ' Create a word sized variable
Busin %10100000, Address, [Str Array] ' Load data into all the array
,
' Load data into only the first 5 elements of the array
,
Busin %10100000, Address, [Str Array\5]
Bstart                          ' Send a Start condition
Busout %10100000                 ' Target an eeprom, and send a WRITE command
Busout 0                          ' Send the HighByte of the address
Busout 0                          ' Send the LowByte of the address
Brestart                          ' Send a Restart condition
Busout %10100001                 ' Target an eeprom, and send a Read command
Busin Str Array                  ' Load all the array with bytes received
Bstop                            ' Send a Stop condition
```

An alternative ending to the above example is: -

```
Busin Str Array\5              ' Load data into only the first 5 elements of the array
Bstop                          ' Send a Stop condition
```

See also : **BusAck**, **Bstart**, **Brestart**, **Bstop**, **Busout**, **HbStart**, **HbRestart**, **HbusAck**, **Hbusin**, **Hbusout**.

Busout

Syntax

Busout *Control*, { *Address* }, [*Variable* {, *Variable*...}]

or

Busout Variable

Overview

Transmit a value to the I²C bus, by first sending the *control* and optional *address* out of the clock pin (*SCL*), and data pin (*SDA*). Or alternatively, if only one operator is included after the **Busout** command, a single value will be transmitted, along with an Ack reception.

Parameters

Variable is a user defined variable or constant.

Control may be a constant value or a **Byte** sized variable expression.

Address may be a constant, variable, or expression.

The **Busout** command is a software implementation (bit-bashed) and operates as an I²C master without using the device's MSSP module, and may be used to interface with any device that complies with the 2-wire I²C protocol.

The most significant 7-bits of *control* byte contain the control code and the slave address of the device being interfaced with. Bit-0 is the flag that indicates whether a read or write command is being implemented.

For example, if we were interfacing to an external eeprom such as the 24LC32, the control code would be %10100000 or \$A0. The most significant 4-bits (1010) are the eeprom's unique slave address. Bits 1 to 3 reflect the three address pins of the eeprom. And Bit-0 is clear to signify that we wish to write to the eeprom. Note that this bit is automatically cleared by the **Busout** command, regardless of its initial value.

Example

```
' Send a byte to the I2C bus.
Device = 24FJ64GA002
Declare Xtal = 8
Declare SCL_Pin = PORTB.3      ' Select the pin for I2C SCL
Declare SDA_Pin = PORTB.4      ' Select the pin for I2C SDA

Dim MyByte as Byte             ' We'll only read 8-bits
Dim Address as Word            ' 16-bit address required
Symbol Control = %10100000     ' Target an eeprom

Address = 20                    ' Write to address 20
MyByte = 200                    ' The value place into address 20
Busout Control, Address,[MyByte] ' Send the byte to the eeprom
DelayMs 10                      ' Allow time for allocation of byte
```

Address, is an optional parameter that may be an 8-bit or 16-bit value. If a variable is used in this position, the size of *address* is dictated by the size of the variable used (**Byte**, **Word** or **Dword**). In the case of the above eeprom interfacing, the 24LC32 eeprom requires a 16-bit address. While the smaller types require an 8-bit address. Make sure you assign the right size address for the device interfaced with, or you may not achieve the results you intended.

The value sent to the bus depends on the size of the variables used. For example: -

```
Dim MyWord as Word      ' Create a Word size variable
Busout Control, Address, [MyWord]
```

Will send a 16-bit value to the bus. While: -

```
Dim MyByte as Byte     ' Create a Byte size variable
Busout Control, Address, [MyByte]
```

Will send an 8-bit value to the bus.

Using more than one variable within the brackets allows differing variable sizes to be sent. For example: -

```
Dim MyByte as Byte
Dim MyWord as Word
Busout Control, Address, [MyByte, MyWord]
```

Will send two values to the bus, the first being an 8-bit value dictated by the size of variable MyByte which has been declared as a byte. And a 16-bit value, this time dictated by the size of the variable MyWord which has been declared as a word. Of course, **Bit** type variables may also be used, but in most cases these are not of any practical use as they still take up a byte within the eeprom.

A string of characters can also be transmitted, by enclosing them in quotes: -

```
Busout Control, Address, ["Hello World", MyByte, MyWord]
```

Using the second variation of the **Busout** command, necessitates using the low level commands i.e. Bstart, Brestart, BusAck, or Bstop.

Using the **Busout** command with only one value after it, sends a byte of data to the I²C bus, and returns holding the Acknowledge reception. This acknowledge indicates whether the data has been received by the slave device.

The Ack reception is returned in the microcontroller's Carry flag, which is **SR.0**, and also System variable **PP4.0**. A value of zero indicates that the data was received correctly, while a one indicates that the data was not received, or that the slave device has sent a NAck return. You must read and understand the datasheet for the device being interfacing to, before the Ack return can be used successfully. An code snippet is shown below: -

```
' Transmit a byte to a 24LC32 serial eeprom
Device = 24FJ64GA002
Declare Xtal = 8
Declare SCL_Pin = PORTB.3      ' Select the pin for I2C SCL
Declare SDA_Pin = PORTB.4     ' Select the pin for I2C SDA

Bstart                        ' Send a Start condition
Busout %10100000              ' Target an eeprom, and send a Write command
Busout 0                       ' Send the High Byte of the address
Busout 0                       ' Send the Low Byte of the address
Busout "A"                    ' Send the value 65 to the bus
If SRbits_C = 1 Then GoTo Not_Received ' Has Ack been received OK?
Bstop                          ' Send a Stop condition
DelayMs 5                      ' Wait for the data to be entered into eeprom
```

Str modifier with Busout.

The **Str** modifier is used for transmitting a string of bytes from a byte array variable. A string is a set of bytes sized values that are arranged or accessed in a certain order. The values 1, 2, 3 would be stored in a string with the value 1 first, followed by 2 then followed by the value 3. A byte array is a similar concept to a string; it contains data that is arranged in a certain order. Each of the elements in an array is the same size. The string 1,2,3 would be stored in a byte array containing three bytes (elements).

Below is an example that sends four bytes from an array: -

```
Device = 24FJ64GA002
Declare Xtal = 16
Declare SCL_Pin = PORTB.3      ' Select the pin for I2C SCL
Declare SDA_Pin = PORTB.4      ' Select the pin for I2C SDA

Dim MyArray[10] as Byte      ' Create a 10-byte array.
MyArray [0] = "A"           ' Load the first 4 bytes of the array
MyArray [1] = "B"           ' With the data to send
MyArray [2] = "C"
MyArray [3] = "D"
Busout %10100000, Address, [Str MyArray\4] ' Send 4-byte string.
```

Note that we use the optional `\n` argument of **Str**. If we didn't specify this, the program would try to keep sending characters until all 10 bytes of the array were transmitted. Since we do not wish all 10 bytes to be transmitted, we chose to tell it explicitly to only send the first 4 bytes.

The above example may also be written as: -

```
Device = 24FJ64GA002
Declare Xtal = 16
Declare SCL_Pin = PORTB.3      ' Select the pin for I2C SCL
Declare SDA_Pin = PORTB.4      ' Select the pin for I2C SDA
Dim MyArray [10] as Byte      ' Create a 10-byte array.
Str MyArray = "ABCD"          ' Load the first 4 bytes of the array
Bstart                         ' Send a Start condition
Busout %10100000              ' Target an eeprom, and send a Write command
Busout 0                       ' Send the HighByte of the address
Busout 0                       ' Send the LowByte of the address
Busout Str MyArray\4          ' Send 4-byte string.
Bstop                         ' Send a Stop condition
```

The above example, has exactly the same function as the previous one. The only differences are that the string is now constructed using the **Str** as a command instead of a modifier, and the low-level Hbus commands have been used.

Declares

There are three **Declare** directives for use with **Busout**.

These are: -

Declare SDA_Pin Port . Pin

Declares the port and pin used for the data line (SDA). This may be any valid port on the microcontroller.

Declare SCL_Pin Port . Pin

Declares the port and pin used for the clock line (SCL). This may be any valid port on the microcontroller.

These declares, as is the case with all the Declares, may only be issued once in any single program, as they setup the I²C library code at design time.

Declare Slow_Bus On - Off or 1 - 0

Slows the bus speed when using an oscillator higher than 4MHz.

The standard speed for the I²C bus is 100KHz. Some devices use a higher bus speed of 400KHz. If you use an 8MHz or higher oscillator, the bus speed may exceed the devices specs, which will result in intermittent transactions, or in some cases, no transactions at all. Therefore, use this **Declare** if you are not sure of the device's spec. The datasheet for the device used will inform you of its bus speed.

Notes.

When the **Busout** command is used, the appropriate SDA and SCL Port and Pin are automatically setup as inputs, and outputs.

Because the I²C protocol calls for an *open-collector* interface, pull-up resistors are required on both the SDA and SCL lines. Values of 1K Ω to 4.7K Ω will suffice.

You may imagine that it's limiting having a fixed set of pins for the I²C interface, but you must remember that several different devices may be attached to a single bus, each having a unique slave address. Which means there is usually no need to use up more than two pins on the device, in order to interface to many devices.

A typical use for the I²C commands is for interfacing with serial eeproms. Shown below is the connections to the I²C bus of a 24LC32 serial eeprom.

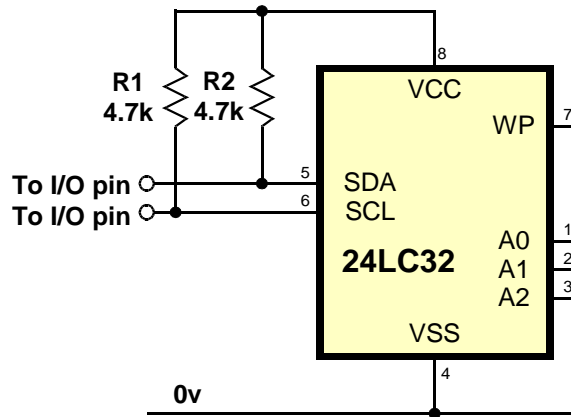

See also : BusAck, Bstart, Brestart, Bstop, Busin, HbStart, HbRestart, HbusAck, Hbusin, Hbusout.

Button

Syntax

Button *Pin, DownState, Delay, Rate, Workspace, TargetState, Label*

Overview

Debounce button input, perform auto-repeat, and branch to address if button is in target state. Button circuits may be active-low or active-high.

Parameters

Pin is a Port.Bit, constant, or variable (0 - 15), that specifies the I/O pin to use. This pin will automatically be set to input.

DownState is a variable, constant, or expression (0 or 1) that specifies which logical state occurs when the button is pressed.

Delay is a variable, constant, or expression (0 - 255) that specifies how long the button must be pressed before auto-repeat starts. The delay is measured in cycles of the **Button** routine. Delay has two special settings: 0 and 255. If Delay is 0, **Button** performs no debounce or auto-repeat. If Delay is 255, **Button** performs debounce, but no auto-repeat.

Rate is a variable, constant, or expression (0 - 255) that specifies the number of cycles between auto-repeats. The rate is expressed in cycles of the **Button** routine.

Workspace is a byte variable used by **Button** for workspace. It must be cleared to 0 before being used by **Button** for the first time and should not be adjusted outside of the **Button** command.

TargetState is a variable, constant, or expression (0 or 1) that specifies which state the button should be in for a branch to occur. (0 = not pressed, 1 = pressed).

Label is a label that specifies where to branch if the button is in the target state.

Example

```
Device = 24FJ64GA002
Declare Xtal = 8
Declare Hserial_Baud = 9600           ' USART1 baud rate
Declare Hrsout1_Pin = PORTB.14       ' Select the pin for TX with USART1

Dim BtnVar as Byte                   ' Workspace for Button command

RPOR7 = 3                             ' Make PPS Pin RP14 U1TX

Do
  ' Go to NoPress unless BtnVar = 0.
  Button 0, 0, 255, 250, BtnVar, 0, NoPress
  HrsoutLn "*"
NoPress:
  Loop
```

Notes.

When a button is pressed, the contacts make or break a connection. A short (1 to 20ms) burst of noise occurs as the contacts scrape and bounce against each other. **Button**'s debounce feature prevents this noise from being interpreted as more than one switch action.

Button also reacts to a button press the way a computer keyboard does to a key press. When a key is pressed, a character immediately appears on the screen. If the key is held down, there's a delay, then a rapid stream of characters appears on the screen. **Button**'s auto-repeat function can be set up to work much the same way.

Button is designed for use inside a program loop. Each time through the loop, **Button** checks the state of the specified pin. When it first matches *DownState*, the switch is debounced. Then, as dictated by *TargetState*, it either branches to *address* (*TargetState* = 1) or doesn't (*TargetState* = 0).

If the switch stays in *DownState*, **Button** counts the number of program loops that execute. When this count equals *Delay*, **Button** once again triggers the action specified by *TargetState* and *address*. Thereafter, if the switch remains in *DownState*, **Button** waits *Rate* number of cycles between actions. The *Workspace* variable is used by **Button** to keep track of how many cycles have occurred since the *pin* switched to *TargetState* or since the last auto-repeat.

Button does not stop program execution. In order for its delay and auto repeat functions to work properly, **Button** must be executed from within a program loop.

Two suitable circuits for use with **Button** are shown below.

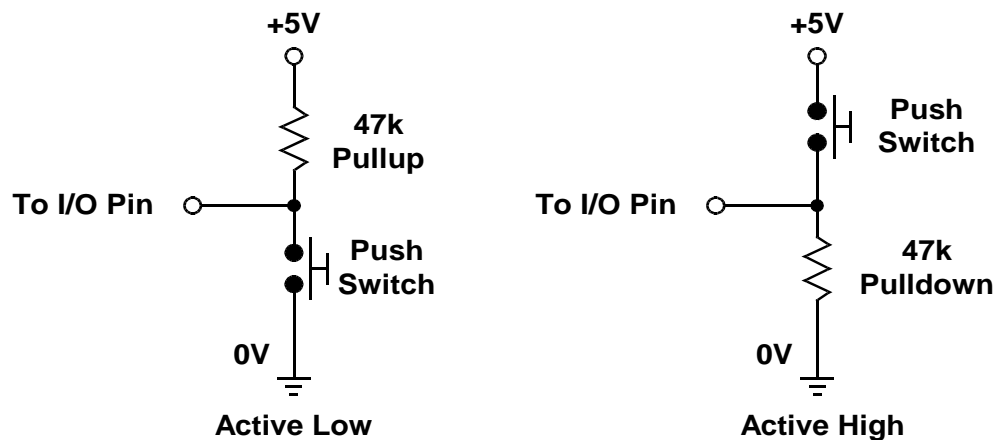

Call

Syntax

Call *Label*

Overview

Execute the assembly language subroutine named *label*.

Parameters

Label must be a valid label name.

Example

```
' Call an assembler routine
```

```
Call Asm_Sub
```

```
Asm
```

```
Asm_Sub:
```

```
{mnemonics}
```

```
Return
```

```
EndAsm
```

Notes.

The **Gosub** command is usually used to execute a BASIC subroutine. However, if your subroutine happens to be written in assembler, the **Call** command should be used. The main difference between **Gosub** and **Call** is that when **Call** is used, the *label's* existence is not checked until assembly time. Using **Call**, a *label* in an assembly language section can be accessed that would otherwise be inaccessible to **Gosub**. This also means that any errors produced will be assembler or linker types, which can be misleading and rather obscure.

See also : **Gosub, GoTo**

Cdata

Syntax

Cdata { *alphanumeric data* }

Overview

Place information directly into memory for access by **Cread8**, **Cread16**, **Cread32** and **Cread64**.

Parameters

alphanumeric data can be any value, alphabetic character, or string enclosed in quotes (") or numeric data without quotes.

Example

```
Device = 24FJ64GA002
Declare Xtal = 8

Dim MyByte as Byte
Dim bIndex as Byte
RPOR7 = 3
For Loop = 0 to 11
    MyByte = Cread8 MyLabel[bIndex]
    Hrsout MyByte
Next
Stop
MyLabel:
Cdata "Hello World\r" ' Create a string of text in code memory
```

The program above reads and displays 12 values from the address located by the Label accompanying the **Cdata** command. Resulting in "Hello World" being displayed.

Formatting a Cdata table.

Sometimes it is necessary to create a data table with a known format for its values. For example all values will occupy 4 bytes of data space even though the value itself would only occupy 1 or 2 bytes.

```
Cdata 100000, 10000, 1000, 100, 10, 1
```

The above line of code would produce an uneven code space usage, as each value requires a different amount of code space to hold the values. 100000 would require 4 bytes of code space, 10000 and 1000 would require 2 bytes, but 100, 10, and 1 would only require 1 byte.

Reading these values using one of the **Cread** commands would cause problems because there is no way of knowing the amount of bytes to read in order to increment to the next valid value.

The answer is to use formatters to ensure that a value occupies a predetermined amount of bytes. These are: -

Byte
Word
Dword
Float
Double

Placing one of these formatters at the beginning of the table will force a given length.

```
Cdata As Dword 100000, 10000, 1000, 100, 10, 1
```

Byte will force all values in the table to occupy one byte of code space, regardless of its value. Any values above 255 will be truncated to the least significant byte.

Word will force the values in the table to occupy 2 bytes of code space, regardless of its value. Any values above 65535 will be truncated to the two least significant bytes. Any value below 255 will be padded to bring the memory count to 2 bytes.

Dword will force the values in the table to occupy 4 bytes of code space, regardless of its value. Any value below 65535 will be padded to bring the memory count to 4 bytes. The line of code shown above uses the **Dword** formatter to ensure all the values in the **Cdata** table occupy 4 bytes of code space.

Float will force the values in the table to their floating point equivalent, which always takes up 4 bytes of code space.

The example below illustrates the formatters in use.

```
' Convert a Dword value into a string. Using only BASIC commands
' Similar principle to the Str$ command
```

```
Device = 24FJ64GA002
Declare Xtal = 8
```

```
Dim Pow10 as Dword           ' Power of 10 variable
Dim bCount as Byte
Dim bTableIndex as Byte
Dim dValue as Dword         ' Value to convert
Dim MyString as String * 12 ' Holds the converted value
Dim bIndex as Byte         ' Index within the string
```

```
RPOR7 = 3                   ' Make PPS Pin RP14 U1TX
DelayMs 10                  ' Wait for things to stabilise
Clear                       ' Clear all RAM before we start
Value = 1234576             ' Value to convert
Gosub DwordToStr           ' Convert Value to string
Hrsout MyString             ' Display the result
Stop
```

```
' Convert a Dword value into a string array
' Value to convert is placed in 'Value'
' Byte array 'Array1' is built up with the ASCII equivalent
'
```

```
DwordToStr:
  bIndex = 0
  bTableIndex = 0
  Repeat
    Pow10 = Cread32 Dword_Table[bTableIndex]
    bCount = 0
    While dValue >= Pow10
      dValue = dValue - Pow10
      Inc bCount
    Wend

    If bCount <> 0 Then
      MyString [bIndex] = bCount + "0"
      Inc bIndex
    EndIf
    Inc bTableIndex
  Until bTableIndex > 8
```

```
MyString[bIndex] = dValue + "0"  
Inc bIndex  
MyString[bIndex] = 0           ' Add the null to terminate the string  
Return  
,  
' Cdata table is formatted for all 32-bit values.  
' Which means each value will require 4 bytes of code space  
Dword_Table:  
  Cdata as Dword 1000000000, 100000000, 10000000, 1000000, 100000, _  
                  10000, 1000, 100, 10
```

Label names as pointers.

If a label's name is used in the list of values in a **Cdata** table, the labels address will be used. This is useful for accessing other tables of data using their address from a lookup table. See example below.

```
' Transmit serially text from two code memory tables  
' Based on their address located in a separate table  
  
Device = 24FJ64GA002  
Declare Xtal = 16  
Declare Hserial_Baud = 9600           ' USART1 baud rate  
Declare Hrsout1_Pin = PORTB.14      ' Select the pin used for TX with USART1  
  
Dim MyByte As Byte  
Dim MyString1 As Code = "Hello",0  
Dim MyString2 As Code = "World",0  
Dim wAddress As Word  
  
,  
' Table of address's  
,  
  
Dim AddrTable As Code = As Word MyString1, MyString2  
  
RPOR7 = 3                           ' Make PPS Pin RP14 U1TX  
wAddress = CRead16 AddrTable[0]      ' Locate the address of first string  
Do                                   ' Create an infinite loop  
  MyByte = cPtr8(wAddress++)          ' Read each character from code memory  
  If MyByte = 0 Then Break           ' Exit when null found  
  HRSOut MyByte                       ' Display the character  
Loop                                  ' Close the loop  
HRSOut 13  
wAddress = CRead16 AddrTable[1]      ' Locate the address of second string  
Do                                   ' Create an infinite loop  
  MyByte = cPtr8(wAddress++)          ' Read each character from code memory  
  If MyByte = 0 Then Break           ' Exit when null found  
  HRSOut MyByte                       ' Display the character  
Loop                                  ' Close the loop
```

Note.

It is not recommended to use **Cdata** in a new program, and may be dropped from future compiler versions. It is recommended to use the **Dim As Code** construct.

See also : **cPtr8, cPtr16, cPtr32, cPtr64, Cread8, Cread16, Cread32, Cread64, Dim.**

Circle

Syntax

Circle *Set_Clear*, *Xpos*, *Ypos*, *Radius*

Overview

Draw a circle on a graphic LCD.

Parameters

Set_Clear may be a constant or variable that determines if the circle will set or clear the pixels. A value of 1 will set the pixels and draw a circle, while a value of 0 will clear any pixels and erase a circle. If using a colour graphic LCD, this parameter holds the 16-bit colour of the pixel.

Xpos may be a constant or variable that holds the X position for the centre of the circle. Can be a value from 0 to the X resolution of the display.

Ypos may be a constant or variable that holds the Y position for the centre of the circle. Can be a value from 0 to the Y resolution of the display.

Radius may be a constant or variable that holds the Radius of the circle. Can be a value from 0 to 65535.

KS0108 LCD example

' Draw circle at pos 63,32 with radius of 20 pixels on a KS0108 LCD

```
Device = 24FJ64GA002
```

```
Declare Xtal = 8
```

```
Declare LCD_Type = KS0108
```

' Setup for a KS0108 graphic LCD

```
Declare LCD_DTPort = PORTB.Byte0
```

' Use the first 8-bits of PORTB

```
Declare LCD_CS1Pin = PORTB.8
```

```
Declare LCD_CS2Pin = PORTB.9
```

```
Declare LCD_ENPin = PORTB.10
```

```
Declare LCD_RSPin = PORTB.11
```

```
Declare LCD_RWPin = PORTB.12
```

```
Dim Xpos as Byte
```

```
Dim Ypos as Byte
```

```
Dim Radius as Byte
```

```
Dim SetClr as Byte
```

```
DelayMs 100
```

' Wait for things to stabilise

```
Cls
```

' Clear the LCD

```
Xpos = 63
```

```
Ypos = 32
```

```
Radius = 20
```

```
SetClr = 1
```

```
Circle SetClr, Xpos, Ypos, Radius
```

ILI9320 colour graphic LCD example

```

' Demonstrate the circle command with a colour LCD
,
Device = 24EP128MC202
Declare Xtal = 140.03
,
' Setup the Pins used by the ILI9320 graphic LCD
,
Declare LCD_DTPort = PORTB.Byte0      ' Use the first 8-bits of PORTB
Declare LCD_CSPin = PORTB.8          ' Connect to the LCD's CS pin
Declare LCD_RDPin = PORTB.9          ' Connect to the LCD's RD pin
Declare LCD_RSPin = PORTB.10         ' Connect to the LCD's RS pin
Declare LCD_WRPin = PORTA.3          ' Connect to the LCD's WR pin

Include "ILI9320.inc"                ' Load the ILI9320 routines into the program

Dim wRadius As Word                  ' Create a variable for the circle's radius

-----
Main:
' Configure the internal Oscillator to operate the device at 140.03MHz
,
PLL_Setup(76, 2, 2, $0300)

Cls clYellow                          ' Clear the LCD with the colour yellow
For wRadius = 0 To 319
    Circle clBrightCyan, 120, 160, wRadius ' Draw a series of circles
Next
-----
' Configure for internal 7.37MHz oscillator with PLL
' OSC pins are general purpose I/O
,
Config FGS = GWRP_OFF, GCP_OFF
Config FOSCSEL = FNOSC_FRCPLL, IESO_ON, PWMLOCK_OFF
Config FOSC = POSCMD_NONE, OSCIOFNC_ON, IOL1WAY_OFF, FCKSM_CSDCMD
Config FWDT = WDTPOST_PS256, WINDIS_OFF, PLLKEN_ON, FWDTEN_OFF
Config FPOR = ALTI2C1_ON, ALTI2C2_OFF
Config FICD = ICS_PGD1, JTAGEN_OFF

```

Notes.

Because of the aspect ratio of the pixels on the KS0108 graphic LCD (approx 1.5 times higher than wide) the circle will appear elongated.

With an ILI9320 320x240 pixel colour graphic LCD, the colour is a 16-bit value formatted in RGB565, where the upper 5-bits represent the red content, the middle 6-bits represent the green content, and the lower 5-bits represent the blue content. As illustrated below:

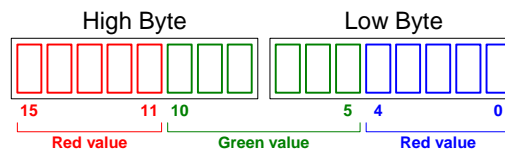

For convenience, there are several colours defined within the ILI9320.inc file. These are:

```
clBlack  
clBrightBlue  
clBrightGreen  
clBrightCyan  
clBrightRed  
clBrightMagenta  
clBrightYellow  
clBlue  
clGreen  
clCyan  
clRed  
clMagenta  
clBrown  
clLightGray  
clDarkGray  
clLightBlue  
clLightGreen  
clLightCyan  
clLightRed  
clLightMagenta  
clYellow  
clWhite
```

More constant values for colours can be added by the user if required.

See Also : **Box, Line, Pixel, Plot, UnPlot.**

Clear

Syntax

Clear *Variable* or *Variable.Bit* or *Pin Number*

Clear

Overview

Place a variable or bit in a low state. For a variable, this means loading it with 0. For a bit this means setting it to 0.

Clear has another purpose. If no variable is present after the command, all user RAM within the device is cleared.

Parameters

Variable can be any variable or register.

Variable.Bit can be any variable and bit combination.

Pin Number can only be a constant that holds a value from 0 to the amount of I/O pins on the device. A value of 0 will be **PORTA.0**, if present, 1 will be **PORTA.1**, 16 will be **PORTB.0** etc... For a variable *Pin Number*, see **ClearPin**.

Example 1

```
Clear                ' Clear all RAM area
Clear Var1.3        ' Clear bit 3 of Var1
Clear Var1          ' Load Var1 with the value of 0
Clear SR.0          ' Clear the carry flag
Clear Array         ' Clear all of an Array variable. i.e. reset to zero's
Clear String1       ' Clear all of a String variable. i.e. reset to zero's
Clear 0              ' Clear PORTA.0
```

Notes.

There is a major difference between the **Clear** and **Low** commands. **Clear** does not alter the TRIS register if a Port is targeted.

See Also : **ClearPin, Set, Low, High, SetPin**

ClearBit

Syntax

ClearBit *Variable, Index*

Overview

Clear a bit of a variable or register using a variable index to the bit of interest.

Parameters

Variable is a user defined variable.

Index is a constant, variable, or expression that points to the bit within *Variable* that requires clearing.

Example

```
' Clear then Set each bit of variable ExVar
Device = 24FJ64GA002
Declare Xtal = 16
Declare Hserial_Baud = 9600      ' USART1 baud rate
Declare Hrsout1_Pin = PORTB.14  ' Select the pin used for TX with USART1

Dim MyByte as Byte
Dim Index as Byte

RPOR7 = 3                        ' Make PPS Pin RP14 U1TX
MyByte = %11111111
Do                                ' Create an infinite loop
  For Index = 0 to 7              ' Create a loop for 8 bits
    ClearBit MyByte, Index        ' Clear each bit of MyByte
    Hrsout Bin8 MyByte , 13       ' Display the binary result
    DelayMs 100                  ' Slow things down to see what's happening
  Next                            ' Close the loop
  For Index = 7 to 0 Step -1      ' Create a loop for 8 bits
    SetBit MyByte, Index          ' Set each bit of MyByte
    Hrsout Bin8 MyByte, 13        ' Display the binary result
    DelayMs 100                  ' Slow things down to see what's happening
  Next                            ' Close the loop
Loop                              ' Do it forever
```

Notes.

There are many ways to clear a bit within a variable, however, each method requires a certain amount of manipulation, either with rotates, or alternatively, the use of indirect addressing. Each method has its merits, but requires a certain amount of knowledge to accomplish the task correctly. The **ClearBit** command makes this task extremely simple using a register rotate method, however, this is not necessarily the quickest method, or the smallest, but it is the easiest. For speed and size optimisation, there is no shortcut to experience.

To clear a known constant bit of a variable or register, then access the bit directly using PORT.n.

```
PORTA.1 = 0
or
Var1.4 = 0
```

If a Port is targeted by **ClearBit**, the TRIS register is **not** affected.

See also : **GetBit, LoadBit, SetBit.**

ClearPin

Syntax

ClearPin *Pin Number*

Overview

Pull a Port's pin low using a variable as the pin's number, but does not set it as an output

Parameters

Pin Number can be a variable or constant or expression that holds a value from 0 to the amount of I/O pins on the device. A value of 0 will be **PORTA.0**, if present, 1 will be **PORTA.1**, 16 will be **PORTB.0** etc...

Example

```
' Clear then Set each pin of PORTB
Device = 24HJ128GP502
Declare Xtal = 16

Dim PinNumber as Byte

High PORTB                                     ' Make PORTB high before we start
Do                                             ' Create a loop
  For PinNumber = 16 to 31                   ' Create a loop for 16 pins
    ClearPin PinNumber                       ' Clear each pin of PORTB
    DelayMs 100                              ' Slow things down to see what's happening
  Next                                       ' Close the loop
  For Index = 16 to 31                       ' Create a loop for 16 pins
    SetPin PinNumber                         ' Set each pin of PORTB
    DelayMs 100                              ' Slow things down to see what's happening
  Next                                       ' Close the loop
Loop                                         ' Do it forever
```

Notes.

There are many ways to pull a pin of an I/O port low, however, each method requires a certain amount of manipulation, either with rotates, or alternatively, the use of indirect addressing. Each method has its merits, but requires a certain amount of knowledge to accomplish the task correctly. The **ClearPin** command makes this task extremely simple using a variable as the pin number, however, this is not necessarily the quickest method, or the smallest, but it is the easiest. For speed and size optimisation, there is no shortcut to experience.

To clear a known constant pin number of a port, access the pin directly using the **Low** command

```
Low PORTA.1
```

Each pin number has a designated name. These are Pin_A0, Pin_A1, Pin_A2, Pin_B0...Pin_B15, Pin_C0...Pin_C15, Pin_D0...Pin_D15 to Pin_L15 etc... Each of the names has a relevant value, for example, Pin_A0 has the value 0, Pin_B0 has the value 16, up to Pin_J15, which has the value 143.

These can be used to pass a relevant pin number to a Procedure. For example:

```
,  
' Flash an LED attached to PORTB.0 via a procedure  
' Then flash an LED attached to PORTB.1 via the same procedure  
,  
  
Device = 24HJ128GP502  
Declare Xtal = 16  
  
Do                               ' Create an infinite loop  
    FlashPin(Pin_B0)             ' Call the procedure to flash PORTB.0  
    FlashPin(Pin_B1)             ' Call the procedure to flash PORTB.1  
Loop                               ' Do it forever  
,  
' Make a pin high then low for 500ms using a variable as the pin to adjust  
,  
  
Proc FlashPin(pPinNumber As Byte)  
    Output pPinNumber            ' Make the pin an output  
    SetPin pPinNumber            ' Bring the pin high  
    DelayMs 500                  ' Wait for 500 milliseconds  
    ClearPin pPinNumber          ' Bring the pin low  
    DelayMs 500                  ' Wait for 500 milliseconds  
EndProc
```

Example 2

```
' Clear then Set each pin of PORTC  
Device = 24HJ128GP502  
Declare Xtal = 16  
  
Dim PinNumber as Byte  
  
High PORTC                        ' Make PORTC output high before we start  
Do                                  ' Create a loop  
    For PinNumber = Pin_C0 to Pin_C7 ' Create a loop for 8 pins  
        ClearPin PinNumber          ' Clear each pin of PORTC  
        DelayMs 100                 ' Slow things down to see what's happening  
    Next                             ' Close the loop  
    For PinNumber = Pin_C0 to Pin_C7 ' Create a loop for 8 pins  
        SetPin PinNumber            ' Set each pin of PORTC  
        DelayMs 100                 ' Slow things down to see what's happening  
    Next                             ' Close the loop  
Loop                               ' Do it forever
```

See also : **SetPin, High, Low.**

ClS

Syntax ClS

or if using a Toshiba T6963 graphic LCD:

ClS Text ClS Graphic

or if using a colour graphic LCD:

ClS Colour

Overview

Clears the alphanumeric or graphic LCD and places the cursor at the home position i.e. line 1, position 1 (line 0, position 0 for graphic LCDs).

Toshiba graphic LCDs based upon the T6963 chipset have separate RAM for text and graphics. Issuing the word **Text** after the **ClS** command will only clear the Text RAM, while issuing the word **Graphic** after the **ClS** command will only clear the Graphic RAM. Issuing the **ClS** command on its own will clear both areas of RAM.

Example 1

```
' Clear a KS0108 graphic LCD
Device = 24FJ64GA002
Declare Xtal = 16

Declare LCD_Type = KS0108           ' Setup for a KS0108 graphic LCD
Declare LCD_DTPort = PORTB.Byte0    ' Use the first 8-bits of PORTB
Declare LCD_CS1Pin = PORTB.8
Declare LCD_CS2Pin = PORTB.9
Declare LCD_ENPin = PORTB.10
Declare LCD_RSPin = PORTB.11
Declare LCD_RWPin = PORTB.12

DelayMs 100                          ' Wait for things to stabilise
ClS                                  ' Clear the LCD
Print "Hello"                         ' Display the word "Hello" on the LCD
Cursor 2,1                            ' Move the cursor to line 2, position 1
Print "World"                         ' Display the word "World" on the LCD
```

In the above example, the LCD is cleared using the **ClS** command, which also places the cursor at the home position i.e. line 1, position 1. Next, the word “Hello” is displayed in the top left corner. The cursor is then moved to line 2 position 1, and the word “World” is displayed.

Example 2

```
' Clear a Toshiba T6963 graphic LCD.
Device = 24FJ64GA002
Declare xtal = 16

Include "T6963C.inc"      ' Load the T6963C routines into the program

Cls                       ' Clear all RAM within the LCD
Print "Hello"            ' Display the word "Hello" on the LCD
Line 1,0,0,63,63        ' Draw a line on the LCD
DelayMs 1000             ' Wait for 1 second
Cls Text                 ' Clear only the text RAM, leaving the line displayed
DelayMs 1000             ' Wait for 1 second
Cls Graphic              ' Now clear the line from the display
```

See also : [Cursor](#), [Print](#), [Toshiba_Command](#).

Config

Syntax

Config *Register Name* = *Fuse Name*, *Fuse Name* {,*Fuse Name*}

Overview

Enable or Disable particular fuse settings for the device being used.

Parameters

Register Name is the designated name of the fuse register within the microcontroller. These vary from device family to device family.

Fuse Name is a list of comma delimited texts that represent the fuse to enable or disable accordingly.

At the time of writing, the standard PIC24F[®] devices use the texts **Config1**, **Config2**, **Config3**, and **Config4**, in order to designate a fuse register, depending on the type. However, some of the newer PIC24FV[®] devices and all the the PIC24H[®] and PIC24E[®] and dsPIC33[®] devices use the texts **FBS**, **FGS**, **FOSCSEL**, **FOSC**, **FWDT**, **FPOR**, **FICD**, **FDS** for fuse register designations.

Example 1

```
' Alter the fuses for a standard PIC24F device (24FJ64GA002)
  Config Config1 = JTAGEN_OFF, GCP_OFF, GWRP_OFF, BKBUG_OFF, COE_OFF, _
                  ICS_PGx1, FWDTEN_OFF, WINDIS_OFF, FWPSA_PR128, _
                  WDTPOST_PS256
  Config Config2 = IOL1WAY_OFF, COE_OFF, IESO_OFF, FNOSC_PRI, _
                  FCKSM_CSDCMD, OSCIOFNC_OFF, POSCMD_HS
```

Example 2

```
' Alter the fuses for a PIC24H device (24HJ128GP502)
  Config FBS = BWRP_WRPROTECT_OFF, BSS_NO_FLASH, BSS_NO_BOOT_CODE
  Config FSS = SWRP_WRPROTECT_OFF, SSS_NO_FLASH, RSS_NO_SEC_RAM
  Config FGS = GWRP_OFF, GCP_OFF
  Config FOSCSEL = FNOSC_FRCPLL, IESO_OFF
  Config FOSC = POSCMD_HS, OSCIOFNC_OFF, IOL1WAY_OFF, FCKSM_CSDCMD
  Config FWDT = WDTPOST_PS256, WINDIS_OFF, FWDTEN_OFF
  Config FPOR = FPWRT_PWR128, ALTI2C_OFF
  Config FICD = ICS_PGD1, JTAGEN_OFF
```

Notes.

The device's PPI file has the required fuse designators in its [FUSESTART] section and a list of the valid fuse names in its [CONFIGSTART] section. The default location of the PPI files is:

For Windows XP and Windows 7 (32-bit)

C:\Program Files\ProtonIDE\PDS\Includes\PPI

For Windows 7 (64-bit)

C:\Program Files (x86)\ProtonIDE\PDS\Includes\PPI

For detailed information concerning the configuration fuses, refer to the microcontroller's data-sheet.

The compiler's default fuse settings are for an external oscillator with no PLL. In order for the **Sleep** command's timing to remain correct, always use the fuse setting `WDTPOST_PS256`

Below are a few examples of using the **Config** directive:

Example 1

```
' PIC24F external 8MHz crystal operating at 32MHz using PLL
,
Device = 24FJ64GA002
Declare Xtal = 32

CLKDIV = 0          ' CPU peripheral clock ratio set to 1:1
OSCCON.Bytel = %00010000 ' Enable 4 x PLL '
,
Flash an LED connected to PORTA.0
,
Do
  High PORTA.0
  DelayMS 500
  Low PORTA.0
  DelayMS 500
Loop
,
Configure for external oscillator with PLL
,
Config Config1 = JTAGEN_OFF, GCP_OFF, BKBUG_OFF, _
                COE_OFF, ICS_PGx1, FWDTEN_OFF, WINDIS_OFF, _
                FWPSA_PR128, WDTPOST_PS256
Config Config2 = IOL1WAY_OFF, IESO_OFF, FNOSC_PRIPLL, _
                FCKSM_CSECME, OSCIOFNC_OFF, POSCMOD_HS
```

Example 2

```
' PIC24F internal 8MHz oscillator operating at 32MHz using PLL
,
Device = 24FJ64GA002
Declare Xtal = 32

CLKDIV = 0          ' CPU peripheral clock ratio set to 1:1
OSCCON.Bytel = %00010000 ' Enable 4 x PLL
,
Flash an LED connected to PORTA.0
,
Do
  High PORTA.0
  DelayMS 500
  Low PORTA.0
  DelayMS 500
Loop
,
Configure for internal 8MHz oscillator with PLL
' OSC pins operate as general purpose I/O
,
Config Config1 = JTAGEN_OFF, GCP_OFF, BKBUG_OFF, _
                COE_OFF, ICS_PGx1, FWDTEN_OFF, WINDIS_OFF, _
                FWPSA_PR128, WDTPOST_PS256
Config Config2 = IOL1WAY_OFF, IESO_OFF, FNOSC_PRIPLL, _
                FCKSM_CSDCMD, OSCIOFNC_OFF, POSCMOD_NONE
```

Example 3

```
' PIC24H internal 7.37MHz oscillator operating at 79.23MHz using PLL
,
  Device = 24HJ128GP502
  Declare Xtal = 79.23
,-----
Main:
' Configure the Oscillator to operate the device at 79.23MHz
' Fosc = (7.37 * 43) / (2 * 2) = 79.23MHz (40 MIPS)
,
  PLL_Setup(43, 2, 2, $0300)
,
' Flash an LED connected to PORTA.0
,
  Do
    High PORTA.0
    DelayMS 500
    Low PORTA.0
    DelayMS 500
  Loop
,
' Configure for internal 7.37MHz oscillator with PLL
' OSC pins operate as general purpose I/O
,
  Config FBS = BWRP_WRPROTTECT_OFF
  Config FSS = SWRP_WRPROTTECT_OFF
  Config FGS = GWRP_OFF
  Config FOSCSEL = FNOSC_FRCPLL, IESO_OFF
  Config FOSC = POSCMD_NONE, OSCIOFNC_OFF, IOL1WAY_OFF, FCKSM_CSECME
  Config FWDT = WDTPRST_PS256, WINDIS_OFF, FWDTEN_OFF
  Config FPOR = FPWRT_PWR128, ALTI2C_OFF
  Config FICD = ICS_PGD1, JTAGEN_OFF
```

Example 4

```
' PIC24E internal 7.37MHz oscillator operating at 140.03MHz using PLL
,
  Device = 24EP128MC202
  Declare Xtal = 140.03
,-----
Main:
' Configure the Oscillator to operate the device at 140.03MHz (70 MIPS)
' Fosc = (7.37 * 76) / (2 * 2) = 140.03MHz
,
  PLL_Setup(76, 2, 2, $0300)
,
' Flash an LED connected to PORTA.0
,
  Do
    High PORTA.0
    DelayMS 500
    Low PORTA.0
    DelayMS 500
  Loop
,
' Configure for internal 7.37MHz oscillator with PLL
' OSC pins operate as general purpose I/O
,
  Config FGS = GWRP_OFF
  Config FOSCSEL = FNOSC_FRCPLL, IESO_OFF, PWMLOCK_OFF
  Config FOSC = POSCMD_NONE, OSCIOFNC_ON, IOL1WAY_OFF, FCKSM_CSECME
  Config FWDT = WDTPPOST_PS256, WINDIS_OFF, PLLKEN_ON, FWDTEN_OFF
  Config FPOR = ALTI2C1_ON, ALTI2C2_OFF
  Config FICD = ICS_PGD1, JTAGEN_OFF
```

Example 5

```
' PIC33F internal 7.37MHz oscillator operating at 79.23MHz using PLL
,
    Device = 33FJ128MC802
    Declare Xtal = 79.23
,-----
Main:
' Configure the Oscillator to operate the device at 79.23MHz
' Fosc = (7.37 * 43) / (2 * 2) = 79.23MHz (40 MIPS)
,
    PLL_Setup(43, 2, 2, $0300)
,
' Flash an LED connected to PORTA.0
,
    Do
        High PORTA.0
        DelayMS 500
        Low PORTA.0
        DelayMS 500
    Loop
,
' Configure for internal 7.37MHz oscillator with PLL
' OSC pins operate as general purpose I/O
,
    Config FBS = BWRP_WRPROTECT_OFF
    Config FGS = GWRP_OFF
    Config FOSCSEL = FNOSC_FRCPLL, IESO_OFF
    Config FOSC = POSCMD_NONE, OSCIOFNC_OFF, IOL1WAY_OFF, FCKSM_CSECME
    Config FWDT = WDTPST_PS256, WINDIS_OFF, FWDTEN_OFF
    Config FPOR = FPWRT_PWR128, ALTI2C_OFF
    Config FICD = ICS_PGD1, JTAGEN_OFF
```

Note.

The **PLL_Setup** helper macro can be found within the device's ".def" file. It is required because the dsPIC33E[®], PIC24E[®] and PIC24H[®] devices need an unlock sequence before writing to the **OSCCON** SFR, unlike the PIC24F[®] devices, that can write directly to the **OSCCON** SFR.

Continue

Syntax Continue

Overview

Cause the next iteration of a **For...Next**, **While...Wend**, **Repeat...Until** or **Do...Loop** condition to occur. With a **For...Next** loop, **Continue** will jump to the **Next** part. With a **While...Wend** loop, **Continue** will jump to the **While** part. With a **Repeat...Until** loop, **Continue** will jump to the **Until** part. With **Do...Loop**, **Continue** will jump to the **Loop** part.

Example

```
' Create and display a For-Next loop's iterations, missing out number 10
Device = 24FJ64GA002
Declare Xtal = 16
Declare Hserial_Baud = 9600      ' USART1 baud rate
Declare Hrsout1_Pin = PORTB.14  ' Select the pin for TX with USART1

Dim Index as Byte

RPOR7 = 3                        ' Make PPS Pin RP14 U1TX

For Index = 0 to 19              ' Create a loop of 20 iterations
  If Index = 10 Then Continue   ' Miss out number 10
  HrsoutLn Dec Index           ' Display the counting loop
  DelayMs 100                  ' Slow things down to see what's happening
Next                             ' Close the loop
```

See also : **Break**, **Do...Loop**, **For...Next**, **Repeat...Until**, **While...Wend**.

Counter

Syntax

Assignment Variable = **Counter** *Pin*, *Period*

Overview

Count the number of pulses that appear on *pin* during *period*, and store the result in *variable*.

Parameters

Assignment Variable is a user-defined variable.

Pin is a Port.Pin constant declaration i.e. **PORTA.0**.

Period may be a constant, variable, or expression.

Example

```
' Count the pulses that occur on PORTA.0 within a 100ms period
' and displays the results.

Device = 24FJ64GA002
Declare Xtal = 16
Declare Hserial_Baud = 9600           ' USART1 baud rate
Declare Hrsout1_Pin = PORTB.14       ' Select the pin for TX with USART1

Dim MyWord as Word                   ' Create a word size variable
Symbol Pin = PORTA.0                 ' Assign the input pin to PORTA.0

RPOR7 = 3                             ' Make PPS Pin RP14 U1TX
Do                                    ' Create a loop
    MyWord = Counter Pin, 100         ' Variable MyWord now contains the Count
    HrsoutLn Dec MyWord               ' Display the decimal result
Loop                                  ' Do it forever
```

Notes.

The resolution of *period* is in milliseconds (ms). It obtains its scaling from the oscillator declaration, **Declare Xtal**.

Counter checks the state of the pin in a concise loop, and counts the rising edge of a transition.

See also : **PulseIn**, **Rcin**.

cPtr8, cPtr16, cPtr32, cPtr64

Syntax

Assignment Variable = **cPtr8** (Address)
Assignment Variable = **cPtr16** (Address)
Assignment Variable = **cPtr32** (Address)
Assignment Variable = **cPtr64** (Address)

Overview

Indirectly read code memory using a variable to hold the 16-bit or 32-bit address.

Parameters

Assignment Variable is a user defined variable that holds the result of the indirectly addressed code memory area.

Address is a **Word** or **Dword** variable that holds the 16-bit or 32-bit address of the code memory area of interest.

Address can also post or pre increment or decrement:

- (MyAddress++) Post increment MyAddress after retrieving its RAM location.
- (MyAddress--) Post decrement MyAddress after retrieving its RAM location.
- (++MyAddress) Pre increment MyAddress before retrieving its RAM location.
- (--MyAddress) Pre decrement MyAddress before retrieving its RAM location.

cPtr8 will retrieve a value with an optional 8-bit post or pre increment or decrement.

cPtr16 will retrieve a value with an optional 16-bit post or pre increment or decrement.

cPtr32 will retrieve a value with an optional 32-bit post or pre increment or decrement.

cPtr64 will retrieve a value with an optional 64-bit post or pre increment or decrement.

8-bit Example.

```
'  
' Read 8-bit values indirectly from code memory  
'  
Device = 24FJ64GA002  
Declare Xtal = 16  
Declare Hserial_Baud = 9600           ' UART1 baud rate  
Declare Hrsout1_Pin = PORTB.14       ' Select pin to be used for TX  
'  
' Create an 8-bit code memory array  
'  
Dim CodeArray As Code = as Byte 1, 2, 3, 4, 5, 6, 7, 8, 9, 0  
Dim MyByte As Byte                   ' Create a byte variable  
Dim bIndex As Byte  
Dim wAddress As Word                 ' Create variable to hold 16-bit address  
Main:  
  RPOR7 = 3                           ' Make PPS Pin RP14 U1TX  
'  
' Read from code memory  
'  
wAddress = AddressOf(CodeArray)       ' Load wAddress with address of memory  
While                                  ' Create a loop  
  MyByte = cPtr8(wAddress++)           ' Retrieve from code with post increment  
  If MyByte = 0 Then Break            ' Exit when a null(0) is read from code  
  HRSOutLn Dec MyByte                 ' Transmit the byte read from code  
Wend
```

16-bit Example.

```
,  
' Read 16-bit values indirectly from code memory  
,  
Device = 24FJ64GA002  
Declare Xtal = 16  
Declare Hserial_Baud = 9600           ' UART1 baud rate  
Declare Hrsout1_Pin = PORTB.14       ' Select pin is to be used for TX  
,  
' Create a 16-bit code memory array  
,  
Dim CodeArray As Code = as Word 100, 200, 300, 400, 500, 600, 700, 0  
Dim MyWord As Word                   ' Create a word variable  
Dim bIndex As Byte  
Dim wAddress As Word                 ' Create variable to hold 16-bit address  
  
Main:  
  RPOR7 = 3                           ' Make PPS Pin RP14 U1TX  
,  
' Read from code memory  
,  
  wAddress = AddressOf(CodeArray)     ' Load wAddress with address of memory  
  While                               ' Create a loop  
    MyWord = cPtr16(wAddress++)       ' Retrieve from code with post increment  
    If MyWord = 0 Then Break         ' Exit when a null(0) is read from code  
    HRSOutLn Dec MyWord              ' Transmit the word read from code  
  Wend
```

32-bit Example.

```
,  
' Read 32-bit values indirectly from code memory  
,  
Device = 24FJ64GA002  
Declare Xtal = 16  
Declare Hserial_Baud = 9600           ' UART1 baud rate  
Declare Hrsout1_Pin = PORTB.14       ' Select pin is to be used for TX  
,  
' Create a 32-bit code memory array  
,  
Dim CodeArray As Code = as Dword 100, 200, 300, 400, 500, 600, 700, 0  
Dim MyDword As Dword                 ' Create a dword variable  
Dim bIndex As Byte  
Dim wAddress As Word                 ' Create variable to hold 16-bit address  
  
Main:  
  RPOR7 = 3                           ' Make PPS Pin RP14 U1TX  
,  
' Read from code memory  
,  
  wAddress = AddressOf(CodeArray)     ' Load wAddress with address of memory  
  While                               ' Create a loop  
    MyDword = cPtr32(wAddress++)      ' Retrieve from code with post increment  
    If MyDword = 0 Then Break         ' Exit when a null(0) is read from code  
    HRSOutLn Dec MyDword              ' Transmit the dword read from code  
  Wend
```

See also: [AddressOf](#), [Cread8](#), [Cread16](#), [Cread32](#), [Cread64](#), [Ptr8](#), [Ptr16](#), [Ptr32](#), [Ptr64](#).

Cread8, Cread16, Cread32, Cread64

Syntax

Assignment Variable = **Cread8** *Label* [*Offset Variable*]
or
Assignment Variable = **Cread16** *Label* [*Offset Variable*]
or
Assignment Variable = **Cread32** *Label* [*Offset Variable*]
or
Assignment Variable = **Cread64** *Label* [*Offset Variable*]

Overview

Read an 8, 16, 32 or 64-bit value from a code memory table using an offset of *Offset Variable* and place into *Variable*.

Cread8 will access 8-bit values from a code memory table.

Cread16 will access 16-bit values from a code memory table.

Cread32 will access 32-bit values from a code memory table, this also includes 32-bit floating point values.

Cread64 will access 64-bit values from a code memory table.

Parameters

Assignment Variable is a user defined variable.

Label is a label name given to the code memory table of which values will be read from.

Offset Variable can be a constant value, variable, or expression that points to the location of interest within the code memory table.

Cread8 Example

```
' Extract the second value from within an 8-bit code memory table
',
Device = 24FJ64GA002
Declare Xtal = 16
Declare Hserial_Baud = 9600      ' USART1 baud rate
Declare Hrsout1_Pin = PORTB.14  ' Select the pin for TX with USART1

Dim Offset as Byte              ' Create a Byte size variable for the offset
Dim MyResult as Byte           ' Create a Byte size variable to hold the result
',
' Create a table containing only 8-bit values
',
Dim Byte_Table as Code = as Byte 100, 200

RPOR7 = 3                       ' Make PPS Pin RP14 U1TX

Offset = 1                       ' Point to second value in the code memory table
',
' Read the 8-bit value pointed to by Offset
',
MyResult = Cread8 Byte_Table[Offset]
HrsoutLn Dec MyResult           ' Display the decimal result
```

Cread16 Example

```
' Extract the second value from within a 16-bit code memory table
,
Device = 24FJ64GA002
Declare Xtal = 16
Declare Hserial_Baud = 9600      ' USART1 baud rate
Declare Hrsout1_Pin = PORTB.14  ' Select the pin for TX with USART1

Dim Offset as Byte              ' Create a Byte size variable for the offset
Dim MyResult as Word           ' Create a Word size variable to hold the result
,
' Create a table containing only 16-bit values
,
Dim WordTable as Code = as Word 1234, 5678

RPOR7 = 3                      ' Make PPS Pin RP14 U1TX
Offset = 1                     ' Point to the second value in the code table
,
' Read the 16-bit value pointed to by Offset
,
MyResult = Cread16 WordTable[Offset]
HrsoutLn Dec MyResult          ' Display the decimal result
```

Cread32 Example

```
' Extract the second value from within a 32-bit code memory table
,
Device = 24FJ64GA002
Declare Xtal = 16
Declare Hserial_Baud = 9600      ' USART1 baud rate
Declare Hrsout1_Pin = PORTB.14  ' Select the pin for TX with USART1

Dim Offset as Byte              ' Create a Byte size variable for the offset
Dim MyResult as Dword          ' Create a Dword size variable to hold the result
,
' Create a table containing only 32-bit values
,
Dim DwordTable as Code = as Dword 12340, 56780

RPOR7 = 3                      ' Make PPS Pin RP14 U1TX
Offset = 1                     ' Point to the second value in the code table
,
' Read the 32-bit value pointed to by Offset
,
MyResult = Cread32 DwordTable[Offset]
HrsoutLn Dec MyResult          ' Display the decimal result
```

See also : Dim as code, cPtr8, cPtr16, cPtr32, cPtr64.

Cursor

Syntax

Cursor *Line, Position*

Overview

Move the cursor position on an Alphanumeric or Graphic LCD to a specified line (ypos) and position (xpos).

Parameters

Line is a constant, variable, or expression that corresponds to the line (Ypos) number from 1 to maximum lines (0 to maximum Y resolution if using a graphic LCD).

Position is a constant, variable, or expression that moves the position within the position (Xpos) chosen, from 1 to maximum position (0 to maximum position if using a graphic LCD).

Example 1

```
Device = 24FJ64GA002
Declare Xtal = 16

Declare LCD_DTPin = PORTB.4
Declare LCD_RSPin = PORTA.0
Declare LCD_ENPin = PORTA.1
Declare LCD_Lines = 4
Declare LCD_Interface = 4

Dim Line as Byte
Dim Xpos as Byte

Line = 2
Xpos = 1
Cls                               ' Clear the LCD
Print "Hello"                      ' Display the word "Hello" on the LCD
Cursor Line, Xpos                  ' Move the cursor to line 2, position 1
Print "World"                      ' Display the word "World" on the LCD
```

In the above example, the LCD is cleared using the **Cls** command, which also places the cursor at the home position i.e. line 1, position 1. Next, the word “Hello” is displayed in the top left corner. The cursor is then moved to line 2 position 1, and the word “World” is displayed.

Example 2

```
Device = 24FJ64GA002
Declare Xtal = 16

Declare LCD_DTPin = PORTB.4
Declare LCD_RSPin = PORTA.0
Declare LCD_ENPin = PORTA.1
Declare LCD_Lines = 4
Declare LCD_Interface = 4

Dim Xpos as Byte
Dim Ypos as Byte

Do                                     ' Create an infinite loop
  Ypos = 1                             ' Start on line 1
  For Xpos = 1 to 16                   ' Create a loop of 16
    Cls                                ' Clear the LCD
    Cursor Ypos, Xpos                 ' Move the cursor to position Ypos,Xpos
    Print "*"                          ' Display the character
    DelayMs 100
  Next
  Ypos = 2                             ' Move to line 2
  For Xpos = 16 to 1 Step -1          ' Create another loop, this time reverse
    Cls                                ' Clear the LCD
    Cursor Ypos, Xpos                 ' Move the cursor to position Ypos,Xpos
    Print "*"                          ' Display the character
    DelayMs 100
  Next
Loop                                   ' Do it forever
```

Example 2 displays an asterisk character moving around the perimeter of a 2-line by 16 character LCD.

See also : Cls, Print

Dec

Syntax

Dec Variable

Overview

Decrement a variable i.e. $Var1 = Var1 - 1$

Parameters

Variable is a user defined variable

Example

```
Device = 24FJ64GA002
Declare Xtal = 16
Declare Hserial_Baud = 9600      ' USART1 baud rate
Declare Hrsout1_Pin = PORTB.14  ' Select the pin for TX with USART1

Dim MyWord as Word

RPOR7 = 3                        ' Make PPS Pin RP14 U1TX
MyWord = 11
Do
    Dec MyWord
    Hrsout Dec MyWord, 13
    DelayMs 200
Loop Until MyWord = 0
```

The above example shows the equivalent to the **For-Next** loop: -

```
For MyWord = 10 to 0 Step -1
Next
```

See also : **Inc.**

Declare

Syntax

Declare *Code Modifying Directive* = *Modifying Value*

Overview

Adjust certain aspects of the produced code at compile time, i.e. Crystal frequency, LCD port and pins, serial baud rate etc.

Parameters

Code Modifying Directive is a set of pre-defined words. See list below.

Modifying Value is the value that corresponds to the action. See list below.

The **Declare** directive is an indispensable part of the compiler. It moulds the library subroutines, and passes essential user information to them.

Note.

The **Declare** directive is mandatory and must precede the texts, otherwise a syntax error will be produced.

The **Declare** directive usually alters the corresponding library subroutine at compile time. This means that once the **Declare** is added to the BASIC program, it usually cannot be Undeclared later, or changed in any way. However, there are some declares that alter the flow of code, and can be enabled and disabled throughout the BASIC listing.

Misc Declares.

Declare WatchDog = On or Off, or True or False, or 1, 0

The **WatchDog Declare** directive enables or disables the **ClrWdt** mnemonic within strategic locations of the compiler's library subroutines. Unlike Proton for 8-bit microcontrollers, it does **not** enable the watchdog fuse. This must be done by using the **Config** directive. The default for the compiler is **WatchDog Off**, therefore, if the watchdog timer is required, then this **Declare** will need to be invoked.

Declare Warnings = On or Off, or True or False, or 1, 0

The **Warnings Declare** directive enables or disables the compiler's warning messages. This can have disastrous results if a warning is missed or ignored, so use this directive sparingly, and at your own peril.

The **Warnings Declare** can be issued multiple times within the BASIC code, enabling and disabling the warning messages at key points in the code as and when required.

Declare Reminders = On or Off, or True or False, or 1, 0

The **Reminders Declare** directive enables or disables the compiler's reminder messages. The compiler issues a reminder for a reason, so use this directive sparingly, and at your own peril.

The **Reminders Declare** can be issued multiple times within the BASIC code, enabling and disabling the reminder messages at key points in the code as and when required.

Declare Access_Upper_64K = On or Off, or True or False, or 1, 0

Some PIC24[®] and dsPIC[®] devices have very large amounts of code memory storage, however, because the architecture of the devices is 16-bit, the largest address that can be accessed with a single mnemonic is 65535 bytes. When this address is exceeded, the device's **TBLPAG** SFR must be loaded with the 17th, 18th, up to 24th bit of the address.

Note that this only applies to data stored in code memory using the **Cdata** directive or very large data segments using the **Dim as Code** directive. It does not usually affect normal commands or mnemonics.

When the **Access_Upper_64K** declare is used, the compiler will add code that manipulates the **TBLPAG** SFR, however, this will impact on the code size produced by the compiler.

Adin Declares.

Declare Adin_Tad c1_FOSC, c2_FOSC, c4_FOSC, c8_FOSC, c16_FOSC, c32_FOSC, c64_FOSC, or cFRC.

Sets the ADC's clock source.

All compatible devices have multiple options for the clock source used by the ADC peripheral. 1_FOSC, 2_FOSC, 4_FOSC, 8_FOSC, 16_FOSC, 32_FOSC, and 64_FOSC are ratios of the external oscillator, while FRC is the device's internal RC oscillator.

Care must be used when issuing this **Declare**, as the wrong type of clock source may result in poor accuracy, or no conversion at all. If in doubt use FRC which will produce a slight reduction in accuracy and conversion speed, but is guaranteed to work first time, every time. FRC is the default setting if the **Declare** is not issued in the BASIC listing.

Declare Adin_Stime 0 to 65535 microseconds (us).

Allows the internal capacitors to fully charge before a sample is taken. This may be a value from 0 to 65535 microseconds (us).

A value too small may result in a reduction of resolution. While too large a value will result in poor conversion speeds without any extra resolution being attained.

A typical value for **Adin_Stime** is 2 to 100. This allows adequate charge time without losing too much conversion speed. But experimentation will produce the right value for your particular requirement. The default value if the **Declare** is not used in the BASIC listing is 50.

Busin - Busout Declares.

Declare SDA_Pin Port . Pin

Declares the port and pin used for the data line (SDA). This may be any valid port on the microcontroller. If this declare is not issued in the BASIC program, then the default Port and Pin is PORTA.0

Declare SCL_Pin Port . Pin

Declares the port and pin used for the clock line (SCL). This may be any valid port on the microcontroller. If this declare is not issued in the BASIC program, then the default Port and Pin is PORTA.1

Declare Slow_Bus On - Off or 1 - 0

Slows the bus speed when using an oscillator higher than 4MHz.

The standard speed for the I²C bus is 100KHz. Some devices use a higher bus speed of 400KHz. If you use an 8MHz or higher oscillator, the bus speed may exceed the devices specs, which will result in intermittent writes or reads, or in some cases, none at all. Therefore, use this **Declare** if you are not sure of the device's spec. The datasheet for the device used will inform you of its bus speed.

Declare Bus_SCL On - Off, 1 - 0 or True - False

Eliminates the necessity for a pull-up resistor on the SCL line.

The I²C protocol dictates that a pull-up resistor is required on both the SCL and SDA lines, however, this is not always possible due to circuit restrictions etc, so once the **Bus_SCL On Declare** is issued at the top of the program, the resistor on the SCL line can be omitted from the circuit. The default for the compiler if the **Bus_SCL Declare** is not issued, is that a pull-up resistor is required.

Hbusin - Hbusout Declares.

Declare HSDA_Pin Port . Pin

Declares the port and pin used for the data line (SDA). The location of the port and pin used for hardware I²C can be altered by the fuse configurations. If the declare is not used in the program, it will default to the standard pin configuration.

Declare HSCL_Pin Port . Pin

Declares the port and pin used for the clock line (SCL). The location of the port and pin used for hardware I²C can be altered by the fuse configurations. If the declare is not used in the program, it will default to the standard pin configuration.

Declare Hbus_Bitrate Constant 100, 400, 1000 etc.

The standard speed for the I²C bus is 100KHz. Some devices use a higher bus speed of 400KHz. The above **Declare** allows the I²C bus speed to be increased or decreased. Use this **Declare** with caution, as too high a bit rate may exceed the device's specs, which will result in intermittent transactions, or in some cases, no transactions at all. The datasheet for the device used will inform you of its bus speed. The default bit rate is the standard 100KHz.

USART1 Declares for Hserin, Hserout, Hrsin and Hrsout.

Declare **HRsout_Pin** Port . Pin

Declares the port and pin used for USART1 transmission (TX). The location of the port and pin is dictated by the device's PPS (Peripheral Pin Select) options. Note that this declare will not alter any PPS (Peripheral Pin Select) SFRs.

There is no default setting for this **Declare** and it must be used within the BASIC program.

Declare **HRsin_Pin** Port . Pin

Declares the port and pin used for USART1 reception (RX). The location of the port and pin is dictated by the device's PPS (Peripheral Pin Select) options. Note that this declare will not alter any PPS (Peripheral Pin Select) SFRs.

There is no default setting for this **Declare** and it must be used within the BASIC program.

Declare **Hserial_Baud** Constant value

Sets the Baud rate that will be used to transmit or receive a byte serially. The baud rate is calculated using the **Xtal** frequency declared in the program. The default baud rate if the **Declare** is not included in the program listing is 9600 baud.

Declare **Hserial_Parity** Odd or Even

Enables/Disables parity on the serial port. For **Hrsin**, **Hrsout**, **Hserin** and **Hserout**. The default serial data format is 8N1, 8 data bits, no parity bit and 1 stop bit. 7E1 (7 data bits, even parity, 1 stop bit) or 7O1 (7data bits, odd parity, 1 stop bit) may be enabled using the **Hserial_Parity** declare.

```
Declare Hserial_Parity = Even      ' Use if even parity desired
Declare Hserial_Parity = Odd      ' Use if odd parity desired
```

Declare **Hserial_Clear** On or Off

Clear the overflow error bit before commencing a read.

Declare **Hrsout_Pace** 0 to 65535 microseconds (us)

Implements a delay between characters transmitted by the **Hrsout** or **HSerout** command.

On occasion, the characters transmitted serially are in a stream that is too fast for the receiver to catch, this results in missed characters. To alleviate this, a delay may be implemented between each individual character transmitted by **Hrsout** or **HSerout**.

If the **Declare** is not used in the program, then the default is no delay between characters.

USART2 Declares for use with Hrsin2, Hserin2, Hrsout2 and Hserout2.

Declare **HRsout2_Pin** Port . Pin

Declares the port and pin used for USART2 transmission (TX). The location of the port and pin is dictated by the device's PPS (Peripheral Pin Select) options. Note that this declare will not alter any PPS (Peripheral Pin Select) SFRs.

There is no default setting for this **Declare** and it must be used within the BASIC program.

Declare **HRsin2_Pin** Port . Pin

Declares the port and pin used for USART2 reception (RX). The location of the port and pin is dictated by the device's PPS (Peripheral Pin Select) options. Note that this declare will not alter any PPS (Peripheral Pin Select) SFRs.

There is no default setting for this **Declare** and it must be used within the BASIC program.

Declare **Hserial2_Baud** Constant value

Sets the Baud rate that will be used to transmit or receive a byte serially. The baud rate is calculated using the **Xtal** frequency declared in the program. The default baud rate if the **Declare** is not included in the program listing is 9600 baud.

Declare **Hserial2_Parity** Odd or Even

Enables/Disables parity on the serial port. For **Hrsout2**, **Hrsin2**, **Hserout2** and **Hserin2**. The default serial data format is 8N1, 8 data bits, no parity bit and 1 stop bit. 7E1 (7 data bits, even parity, 1 stop bit) or 7O1 (7 data bits, odd parity, 1 stop bit) may be enabled using the **Hserial2_Parity** declare.

```
Declare Hserial2_Parity = Even      ' Use if even parity desired
Declare Hserial2_Parity = Odd      ' Use if odd parity desired
```

Declare **Hserial2_Clear** On or Off

Clear the overflow error bit before commencing a read.

```
Declare Hserial2_Clear = On
```

Declare **Hrsout2_Pace** 0 to 65535 microseconds (us)

Implements a delay between characters transmitted by the **Hrsout2** or **HSerout2** command.

On occasion, the characters transmitted serially are in a stream that is too fast for the receiver to catch, this results in missed characters. To alleviate this, a delay may be implemented between each individual character transmitted by **Hrsout2** or **HSerout2**.

If the **Declare** is not used in the program, then the default is no delay between characters.

USART3 Declares for use with Hrsin3, Hserin3, Hrsout3 and Hserout3.

Declare **HRsout3_Pin** Port . Pin

Declares the port and pin used for USART3 transmission (TX). The location of the port and pin is dictated by the device's PPS (Peripheral Pin Select) options. Note that this declare will not alter any PPS (Peripheral Pin Select) SFRs.

There is no default setting for this **Declare** and it must be used within the BASIC program.

Declare **HRsin3_Pin** Port . Pin

Declares the port and pin used for USART3 reception (RX). The location of the port and pin is dictated by the device's PPS (Peripheral Pin Select) options. Note that this declare will not alter any PPS (Peripheral Pin Select) SFRs.

There is no default setting for this **Declare** and it must be used within the BASIC program.

Declare **Hserial3_Baud** Constant value

Sets the Baud rate that will be used to transmit or receive a byte serially. The baud rate is calculated using the **Xtal** frequency declared in the program. The default baud rate if the **Declare** is not included in the program listing is 9600 baud.

Declare **Hserial3_Parity** Odd or Even

Enables/Disables parity on the serial port. For **Hrsout3**, **Hrsin3**, **Hserout3** and **Hserin3**. The default serial data format is 8N1, 8 data bits, no parity bit and 1 stop bit. 7E1 (7 data bits, even parity, 1 stop bit) or 7O1 (7data bits, odd parity, 1 stop bit) may be enabled using the **Hserial3_Parity** declare.

```
Declare Hserial3_Parity = Even ' Use if even parity desired  
Declare Hserial3_Parity = Odd   ' Use if odd parity desired
```

Declare **Hserial3_Clear** On or Off

Clear the overflow error bit before commencing a read.

```
Declare Hserial3_Clear = On
```

Declare **Hrsout3_Pace** 0 to 65535 microseconds (us)

Implements a delay between characters transmitted by the **Hrsout3** or **HSerout3** command.

On occasion, the characters transmitted serially are in a stream that is too fast for the receiver to catch, this results in missed characters. To alleviate this, a delay may be implemented between each individual character transmitted by **Hrsout3** or **HSerout3**.

If the **Declare** is not used in the program, then the default is no delay between characters.

USART4 Declares for use with Hrsin4, Hserin4, Hrsout4 and Hserout4.

Declare **HRsout4_Pin** Port . Pin

Declares the port and pin used for USART4 transmission (TX). The location of the port and pin is dictated by the device's PPS (Peripheral Pin Select) options. Note that this declare will not alter any PPS (Peripheral Pin Select) SFRs.

There is no default setting for this **Declare** and it must be used within the BASIC program.

Declare **HRsin4_Pin** Port . Pin

Declares the port and pin used for USART4 reception (RX). The location of the port and pin is dictated by the device's PPS (Peripheral Pin Select) options. Note that this declare will not alter any PPS (Peripheral Pin Select) SFRs.

There is no default setting for this **Declare** and it must be used within the BASIC program.

Declare **Hserial4_Baud** Constant value

Sets the Baud rate that will be used to transmit or receive a byte serially. The baud rate is calculated using the **Xtal** frequency declared in the program. The default baud rate if the **Declare** is not included in the program listing is 9600 baud.

Declare **Hserial4_Parity** Odd or Even

Enables/Disables parity on the serial port. For **Hrsout4**, **Hrsin4**, **Hserout4** and **Hserin4**. The default serial data format is 8N1, 8 data bits, no parity bit and 1 stop bit. 7E1 (7 data bits, even parity, 1 stop bit) or 7O1 (7data bits, odd parity, 1 stop bit) may be enabled using the **Hserial4_Parity** declare.

```
Declare Hserial4_Parity = Even ' Use if even parity desired  
Declare Hserial4_Parity = Odd   ' Use if odd parity desired
```

Declare **Hserial3_Clear** On or Off

Clear the overflow error bit before commencing a read.

```
Declare Hserial3_Clear = On
```

Declare **Hrsout4_Pace** 0 to 65535 microseconds (us)

Implements a delay between characters transmitted by the **Hrsout4** or **HSerout4** command.

On occasion, the characters transmitted serially are in a stream that is too fast for the receiver to catch, this results in missed characters. To alleviate this, a delay may be implemented between each individual character transmitted by **Hrsout4** or **HSerout4**.

If the **Declare** is not used in the program, then the default is no delay between characters.

Hpwm Declares.

Some devices have alternate pins that may be used for **Hpwm**. The following **Declares** allow the use of different pins: -

```
Declare CCP1_Pin Port.Pin ' Select Hpwm port and bit for CCP1 module (ch 1)  
Declare CCP2_Pin Port.Pin ' Select Hpwm port and bit for CCP2 module (ch 2)  
Declare CCP3_Pin Port.Pin ' Select Hpwm port and bit for CCP3 module (ch 3)  
Declare CCP4_Pin Port.Pin ' Select Hpwm port and bit for CCP4 module (ch 4)  
Declare CCP5_Pin Port.Pin ' Select Hpwm port and bit for CCP5 module (ch 5)
```

Alphanumeric (Hitachi HD44780) LCD Print Declares.

Declare **LCD_DTPin** Port . Pin

Assigns the Port and Pins that the LCD's DT lines will attach to.

The LCD may be connected to the microcontroller using either a 4-bit bus or an 8-bit bus. If an 8-bit bus is used, all 8 bits must be on one port. If a 4-bit bus is used, it must be connected to either the bottom 4 or top 4 bits of one port. For example: -

```
Declare LCD_DTPin PORTB.4 ' Use a 4-line interface on low byte of PORTB
Declare LCD_DTPin PORTB.0 ' Use an 8-line interface on low byte of PORTB
Declare LCD_DTPin PORTB.12 ' Use a 4-line interface on high byte of PORTB
Declare LCD_DTPin PORTB.8 ' Use an 8-line interface on high byte of PORTB
```

In the above examples, **PORTB** is only a personal preference. The LCD's DT lines can be attached to any valid port on the microcontroller.

There is no default setting for this **Declare** and it must be used within the BASIC program.

Declare **LCD_DataX_Pin** Port . Pin

Assigns the individual Ports and Pins that the HD4470 LCD's DT lines will attach to.

Unlike the above **LCD_DTPin** declares, the LCD's data pins can also be attached to any separate port and pin. For example:-

```
Declare LCD_Data0_Pin PORTA.0 ' Connect PORTA.0 to the LCD's D0 line
Declare LCD_Data1_Pin PORTA.2 ' Connect PORTA.2 to the LCD's D1 line
Declare LCD_Data2_Pin PORTA.4 ' Connect PORTA.4 to the LCD's D2 line
Declare LCD_Data3_Pin PORTB.0 ' Connect PORTB.0 to the LCD's D3 line
Declare LCD_Data4_Pin PORTB.1 ' Connect PORTB.1 to the LCD's D4 line
Declare LCD_Data5_Pin PORTB.5 ' Connect PORTB.5 to the LCD's D5 line
Declare LCD_Data6_Pin PORTC.0 ' Connect PORTC.0 to the LCD's D6 line
Declare LCD_Data7_Pin PORTC.1 ' Connect PORTC.1 to the LCD's D7 line
```

There are no default settings for these **Declares** and they must be used within the BASIC program if required.

Declare **LCD_ENPin** Port . Pin

Assigns the Port and Pin that the LCD's EN line will attach to. This also assigns the graphic LCD's EN pin, however, the default value remains the same as for the alphanumeric type, so this will require changing.

There is no default setting for this **Declare** and it must be used within the BASIC program.

Declare **LCD_RSPin** Port . Pin

Assigns the Port and Pins that the LCD's RS line will attach to. This also assigns the graphic LCD's RS pin, however, the default value remains the same as for the alphanumeric type, so this will require changing.

There is no default setting for this **Declare** and it must be used within the BASIC program.

Declare **LCD_Interface** 4 or 8

Inform the compiler as to whether a 4-line or 8-line interface is required by the LCD.

There is no default setting for this **Declare** and it must be used within the BASIC program.

Declare LCD_Lines 1, 2, or 4

Inform the compiler as to how many lines the LCD has.

Alphanumeric HD4470 LCD's come in a range of sizes, the most popular being the 2 line by 16 character types. However, there are 4-line types as well. Simply place the number of lines that the particular LCD has into the declare.

There is no default setting for this **Declare** and it must be used within the BASIC program.

Declare LCD_CommandUS 1 to 65535

Time to wait (in microseconds) between commands sent to the LCD.

If the **Declare** is not used in the program, then the default delay is 2000us (2ms).

Declare LCD_DataUs 1 to 65535

Time to wait (in microseconds) between data sent to the LCD.

If the **Declare** is not used in the program, then the default delay is 50us.

Graphic LCD Declares.

Declare **LCD_Type** Alpha or **Graphic** or **KS0108** or **Toshiba** or **T6963** or **Colour**

Inform the compiler as to the type of LCD that the **Print** command will output to. If **Graphic**, or **KS0108** is chosen then any output by the **Print** command will be directed to a graphic LCD based on the KS0108 chipset. The text **Toshiba**, or **T6963** will direct the output to a graphic LCD based on the Toshiba T6963 chipset. The text **Colour** will direct the output to an ILI9320 Colour Graphic LCD. The text **Alpha**, or if the **Declare** is not issued, will target the standard Hitachi HD44780 alphanumeric LCD type

Targeting the graphic LCD will also enable commands such as **Plot**, **UnPlot**, **LCDread**, **LCDwrite**, **Pixel**, **Box**, **Circle** and **Line** etc.

KS0108 Graphic LCD specific Declares.

Declare **LCD_DTPort** Port

Assign the port that will output the 8-bit data to the graphic LCD.

There is no default setting for this **Declare** and it must be used within the BASIC program.

Declare **LCD_RWPIn** Port . Pin

Assigns the Port and Pin that the graphic LCD's RW line will attach to.

There is no default setting for this **Declare** and it must be used within the BASIC program.

Declare **LCD_ENPin** Port . Pin

Assigns the Port and Pin that the graphic LCD's EN line will attach to.

There is no default setting for this **Declare** and it must be used within the BASIC program.

Declare **LCD_RSPin** Port . Pin

Assigns the Port and Pins that the graphic LCD's RS line will attach to.

There is no default setting for this **Declare** and it must be used within the BASIC program.

Declare **LCD_CS1Pin** Port . Pin

Assigns the Port and Pin that the graphic LCD's CS1 line will attach to.

There is no default setting for this **Declare** and it must be used within the BASIC program.

Declare **LCD_CS2Pin** Port . Pin

Assigns the Port and Pin that the graphic LCD's CS2 line will attach to.

There is no default setting for this **Declare** and it must be used within the BASIC program.

Declare **GLCD_CS_Invert** On - Off, 1 or 0

Some graphic LCD types have inverters on their CS lines. Which means that the LCD displays left hand data on the right side, and vice-versa. The **GLCD_CS_Invert Declare**, adjusts the library LCD handling library subroutines to take this into account.

Declare GLCD_Strobe_Delay 0 to 16383 cycles.

If a noisy circuit layout is unavoidable when using a graphic LCD, then the above **Declare** may be used. This will create a delay between the Enable line being strobed. This can ease random data being produced on the LCD's screen.

If the **Declare** is not used in the program, then the cycles delay is determined by the oscillator used.

Toshiba T6963C Graphic LCD specific Declares.

Declare LCD_DTPort Port

Assign the port that will output the 8-bit data to the graphic LCD.

There is no default setting for this **Declare** and it must be used within the BASIC program.

Declare LCD_WRPin Port . Pin

Assigns the Port and Pin that the graphic LCD's WR line will attach to.

There is no default setting for this **Declare** and it must be used within the BASIC program.

Declare LCD_RDPin Port . Pin

Assigns the Port and Pin that the graphic LCD's RD line will attach to.

There is no default setting for this **Declare** and it must be used within the BASIC program.

Declare LCD_CEPin Port . Pin

Assigns the Port and Pin that the graphic LCD's CE line will attach to.

There is no default setting for this **Declare** and it must be used within the BASIC program.

Declare LCD_CDPin Port . Pin

Assigns the Port and Pin that the graphic LCD's CD line will attach to.

There is no default setting for this **Declare** and it must be used within the BASIC program.

Declare LCD_RSTPin Port . Pin

Assigns the Port and Pin that the graphic LCD's RST line will attach to.

The LCD's RST (Reset) **Declare** is optional and if omitted from the BASIC code the compiler will not manipulate it. However, if not used as part of the interface, you must set the LCD's RST pin high for normal operation.

Declare LCD_X_Res 0 to 255

LCD displays using the T6963 chipset come in varied screen sizes (resolutions). The compiler must know how many horizontal pixels the display consists of before it can build its library sub-routines.

There is no default setting for this **Declare** and it must be used within the BASIC program.

Declare LCD_Y_Res 0 to 255

LCD displays using the T6963 chipset come in varied screen sizes (resolutions). The compiler must know how many vertical pixels the display consists of before it can build its library subroutines.

There is no default setting for this **Declare** and it must be used within the BASIC program.

Declare LCD_Font_Width 6 or 8

The Toshiba T6963 graphic LCDs have two internal font sizes, 6 pixels wide by eight high, or 8 pixels wide by 8 high. The particular font size is chosen by the LCD's FS pin. Leaving the FS pin floating or bringing it high will choose the 6 pixel font, while pulling the FS pin low will choose the 8 pixel font. The compiler must know what size font is required so that it can calculate screen and RAM boundaries.

Note that the compiler does not control the FS pin and it is down to the circuit layout whether or not it is pulled high or low. There is no default setting for this **Declare** and it must be used within the BASIC program.

Declare LCD_RAM_Size 1024 to 65535

Toshiba graphic LCDs contain internal RAM used for Text, Graphic or Character Generation. The amount of RAM is usually dictated by the display's resolution. The larger the display, the more RAM is normally present. Standard displays with a resolution of 128x64 typically contain 4096 bytes of RAM, while larger types such as 240x64 or 190x128 typically contain 8192 bytes or RAM. The display's datasheet will inform you of the amount of RAM present.

If this **Declare** is not issued within the BASIC program, the default setting is 8192 bytes.

Declare LCD_Text_Pages 1 to n

As mentioned above, Toshiba graphic LCDs contain RAM that is set aside for text, graphics or characters generation. In normal use, only one page of text is all that is required, however, the compiler can re-arrange its library subroutines to allow several pages of text that is continuous. The amount of pages obtainable is directly proportional to the RAM available within the LCD itself. Larger displays require more RAM per page, therefore always limit the amount of pages to only the amount actually required or unexpected results may be observed as text, graphic and character generator RAM areas merge.

This **Declare** is purely optional and is usually not required. There is no default setting for this **Declare**.

Declare LCD_Text_Home_Address 0 to n

The RAM within a Toshiba graphic LCD is split into three distinct uses, text, graphics and character generation. Each area of RAM must not overlap or corruption will appear on the display as one uses the other's assigned space. The compiler's library subroutines calculate each area of RAM based upon where the text RAM starts. Normally the text RAM starts at address 0, however, there may be occasions when it needs to be set a little higher in RAM. The order of RAM is; Text, Graphic, then Character Generation.

This **Declare** is purely optional and is usually not required. There is no default setting for this **Declare**.

ILI9320 Colour Graphic LCD specific Declares.

Declare LCD_DTPort Port

Assign the port that will output the 8-bit data to the graphic LCD.

There is no default setting for this **Declare** and it must be used within the BASIC program.

Declare LCD_WRPin Port . Pin

Assigns the Port and Pin that the graphic LCD's WR line will attach to.

There is no default setting for this **Declare** and it must be used within the BASIC program.

Declare LCD_RDPin Port . Pin

Assigns the Port and Pin that the graphic LCD's RD line will attach to.

There is no default setting for this **Declare** and it must be used within the BASIC program.

Declare LCD_CSPin Port . Pin

Assigns the Port and Pin that the graphic LCD's CS line will attach to.

There is no default setting for this **Declare** and it must be used within the BASIC program.

Declare LCD_RSPin Port . Pin

Assigns the Port and Pins that the graphic LCD's RS line will attach to.

There is no default setting for this **Declare** and it must be used within the BASIC program.

Declare LCD_RSTPin Port . Pin

Assigns the Port and Pin that the graphic LCD's RST line will attach to.

The LCD's RST (Reset) **Declare** is optional and if omitted from the BASIC code the compiler will not manipulate it. However, if not used as part of the interface, you must set the LCD's RST pin high for normal operation.

ADS7846 Touch Screen controller Declares.

Declare Touch_CSPin Port . Pin

Assigns the Port and Pin that will attach to the ADS7846 chip's CS pin.

There is no default setting for this **Declare** and it must be used within the BASIC program.

Declare Touch_CLKPin Port . Pin

Assigns the Port and Pin that will attach to the ADS7846 chip's CLK pin.

There is no default setting for this **Declare** and it must be used within the BASIC program.

Declare Touch_DINPin Port . Pin

Assigns the Port and Pin that will attach to the ADS7846 chip's DIN pin.

There is no default setting for this **Declare** and it must be used within the BASIC program.

Declare Touch_DOUTPin Port . Pin

Assigns the Port and Pin that will attach to the ADS7846 chip's DOUT pin.

There is no default setting for this **Declare** and it must be used within the BASIC program.

Keypad Declare.

Declare Keypad_Port Port

Assigns the Port that the keypad is attached to.

Rsin - Rsout Declares.

Declare Rsout_Pin Port . Pin

Assigns the Port and Pin that will be used to output serial data from the **Rsout** command. This may be any valid port on the microcontroller.

If the **Declare** is not used in the program, then the default Port and Pin is PORTB.0.

Declare Rsin_Pin Port . Pin

Assigns the Port and Pin that will be used to input serial data by the **Rsin** command. This may be any valid port on the microcontroller.

If the **Declare** is not used in the program, then the default Port and Pin is PORTB.1.

Declare Rsout_Mode True or Inverted or 1, 0

Sets the serial mode for the data transmitted by **Rsout**. This may be inverted or true. Alternatively, a value of 1 may be substituted to represent inverted, and 0 for true.

If the **Declare** is not used in the program, then the default mode is inverted.

Declare Rsin_Mode True or Inverted or 1, 0

Sets the serial mode for the data received by **Rsin**. This may be inverted or true. Alternatively, a value of 1 may be substituted to represent inverted, and 0 for true.

If the **Declare** is not used in the program, then the default mode is inverted.

Declare Serial_Baud 0 to 65535 bps (baud)

Informs the **Rsin** and **Rsout** routines as to what baud rate to receive and transmit data.

Virtually any baud rate may be transmitted and received (within reason), but there are standard bauds, namely: -

300, 600, 1200, 2400, 4800, 9600, and 19200 etc...

When using a 4MHz crystal, the highest baud rate that is reliably achievable is 9600. However, an increase in the oscillator speed allows higher baud rates to be achieved, including 38400 baud and above.

If the **Declare** is not used in the program, then the default baud is 9600.

Declare Rsout_Pace 0 to 65535 microseconds (us)

Implements a delay between characters transmitted by the **Rsout** command.

On occasion, the characters transmitted serially are in a stream that is too fast for the receiver to catch, this results in missed characters. To alleviate this, a delay may be implemented between each individual character transmitted by **Rsout**.

If the **Declare** is not used in the program, then the default is no delay between characters.

Declare Rsin_Timeout 0 to 65535 milliseconds (ms)

Sets the time, in ms, that **Rsin** will wait for a start bit to occur.

Rsin waits in a tight loop for the presence of a start bit. If no timeout parameter is issued, then it will wait forever.

The Rsin command has the option of jumping out of the loop if no start bit is detected within the time allocated by timeout.

If the **Declare** is not used in the program, then the default timeout value is 10000ms which is 10 seconds.

Serin - Serout Declare.

If communications are with existing software or hardware, its speed and mode will determine the choice of baud rate and mode. In general, 7-bit/even-parity (7E) mode is used for text, and 8-bit/no-parity (8N) for byte-oriented data. Note: the most common mode is 8-bit/no-parity, even when the data transmitted is just text. Most devices that use a 7-bit data mode do so in order to take advantage of the parity feature. Parity can detect some communication errors, but to use it you lose one data bit. This means that incoming data bytes transferred in 7E (even-parity) mode can only represent values from 0 to 127, rather than the 0 to 255 of 8N (no-parity) mode.

The compiler's serial commands **Serin** and **Serout** have the option of still using a parity bit with 4 to 8 data bits. This is through the use of a **Declare**: -

With parity disabled (the default setting): -

```
Declare Serial_Data 4 ' Set Serin and Serout data bits to 4
Declare Serial_Data 5 ' Set Serin and Serout data bits to 5
Declare Serial_Data 6 ' Set Serin and Serout data bits to 6
Declare Serial_Data 7 ' Set Serin and Serout data bits to 7
Declare Serial_Data 8 ' Set Serin and Serout data bits to 8 (default)
```

With parity enabled: -

```
Declare Serial_Data 5 ' Set Serin and Serout data bits to 4
Declare Serial_Data 6 ' Set Serin and Serout data bits to 5
Declare Serial_Data 7 ' Set Serin and Serout data bits to 6
Declare Serial_Data 8 ' Set Serin and Serout data bits to 7 (default)
Declare Serial_Data 9 ' Set Serin and Serout data bits to 8
```

Serial_Data data bits may range from 4 bits to 8 (the default if no **Declare** is issued). Enabling parity uses one of the number of bits specified.

Declaring **Serial_Data** as 9 allows 8 bits to be read and written along with a 9th parity bit.

Parity is a simple error-checking feature. When a serial sender is set for even parity (the mode the compiler supports) it counts the number of 1s in an outgoing byte and uses the parity bit to make that number even. For example, if it is sending the 7-bit value: %0011010, it sets the parity bit to 1 in order to make an even number of 1s (four).

The receiver also counts the data bits to calculate what the parity bit should be. If it matches the parity bit received, the serial receiver assumes that the data was received correctly. Of course, this is not necessarily true, since two incorrectly received bits could make parity seem correct when the data was wrong, or the parity bit itself could be bad when the rest of the data was correct.

Many systems that work exclusively with text use 7-bit/ even-parity mode. For example, to receive one data byte through bit-0 of PORTA at 9600 baud, 7E, inverted:

Shin - Shout Declare.

Declare Shift_DelayUs 0 - 65535 microseconds (us)

Extend the active state of the shift clock.

The clock used by **Shin** and **Shout** runs at approximately 45KHz dependent on the oscillator frequency. The active state is held for a minimum of 2 microseconds, again depending on the oscillator. By placing this declare in the program, the active state of the clock is extended by an additional number of microseconds up to 65535 (65.535 milliseconds) to slow down the clock rate.

If the **Declare** is not used in the program, then the default is no clock delay.

Stack Declares.

Declare Stack_Size = 20 to n (in words)

The compiler sets the default size of the microcontroller's stack to 60 words (120 bytes). This can be increased or decreased as required, as long as it fits within the RAM available. The compiler places a minimum limit of 20 for stack size. If the stack overflows or underflows, the microcontroller will trigger an exception. The compiler's command library routines make extensive use of the stack for saving and restoring WREG SFRs, therefore, make sure the stack is large enough to accommodate all the **Gosub/Return** commands, as well as temporary data used.

When 64-bit floating point **Double** variables are being used in trigonometry routines, it is important to increase the stack size because the library routines use the stack intensively as temporary storage. A stack size of 200 words will usually suffice. If the program resets intermittently, the stack size is too small and the microcontroller is executing an over/under stack exception.

Declare Stack_Expand = 1 or 0 or On or Off

Whenever an interrupt handler is used within a BASIC program, it must context save and restore critical SFRs and variables that would otherwise get overwritten. It uses the microcontroller's stack for temporary storage of the SFRs and variables, therefore the stack will increase with every interrupt handler used within the program. If this behaviour is undesirable, the above declare will disable it. However, the user must make sure that the stack is large enough to accommodate the storage, otherwise an exception will be triggered by the microcontroller.

Oscillator Frequency Declare.

Declare Xtal = Frequency (in MHz).

Inform the compiler what frequency oscillator is being used. For example:

```
Declare Xtal = 7.37
```

OR

```
Declare Xtal = 80
```

Some commands are very dependant on the oscillator frequency, **Rsin**, **Rout**, **DelayMs**, and **DelayUs** being just a few. In order for the compiler to adjust the correct timing for these commands, it must know what frequency crystal is being used.

Note

The **Xtal** declare will not alter any fuse settings or SFRs (Special Function Registers) relating to the oscillator setup. There is no default value if the **Declare** is not issued in a program, and it should be considered as a mandatory addition to the code.

PIC24[®] and dsPIC33[®] devices have a multitude of oscillator options, therefore, they cannot all be detailed in this manual. However, shown below are some examples that illustrate methods of using an external crystal and the internal oscillator, both with and without the PLL multiplier.

Example 1

```
' PIC24F external 8MHz crystal operating at 32MHz using PLL
,
Device = 24FJ64GA002
Declare Xtal = 32

CLKDIV = 0           ' CPU peripheral clock ratio set to 1:1
OSCCON.Bytel = %00010000 ' Enable 4 x PLL '
,
Flash an LED connected to PORTA.0
,
Do
  High PORTA.0
  DelayMS 500
  Low PORTA.0
  DelayMS 500
Loop
,
For external oscillator with PLL
,
Config Config1 = JTAGEN_OFF, GCP_OFF, GWRP_OFF, BKBUG_OFF, _
                COE_OFF, ICS_PGx1, FWDTEN_OFF, WINDIS_OFF, _
                FWPSA_PR128, WDTPOST_PS256
Config Config2 = IOL1WAY_OFF, IESO_OFF, FNOSC_PRIPLL, _
                FCKSM_CSDCMD, OSCIOFNC_OFF, POSCMOD_HS
```

Example 2

```
' PIC24F internal 8MHz oscillator operating at 32MHz using PLL
,
Device = 24FJ64GA002
Declare Xtal = 32

CLKDIV = 0           ' CPU peripheral clock ratio set to 1:1
OSCCON.Bytel = %00010000 ' Enable 4 x PLL
,
Flash an LED connected to PORTA.0
,
While
  High PORTA.0
  DelayMS 500
  Low PORTA.0
  DelayMS 500
Wend
,
For internal 8MHz oscillator with PLL
OSC pins operate as general purpose I/O
,
Config Config1 = JTAGEN_OFF, GCP_OFF, BKBUG_OFF, _
                COE_OFF, ICS_PGx1, FWDTEN_OFF, WINDIS_OFF, _
                FWPSA_PR128, WDTPOST_PS256
Config Config2 = IOL1WAY_OFF, IESO_OFF, FNOSC_PRIPLL, _
                FCKSM_CSECME, OSCIOFNC_OFF, POSCMOD_NONE
```

Example 3

```
' PIC24H internal 7.37MHz oscillator operating at 79.23MHz using PLL
,
Device = 24HJ128GP502
Declare Xtal = 79.23
-----
Main:
' Configure the Oscillator to operate the device at 79.23MHz
' Fosc = (7.37 * 43) / (2 * 2) = 79.23MHz (40 MIPS)
,
  PLL_Setup(43, 2, 2, $0300)
,
Flash an LED connected to PORTA.0
,
While
  High PORTA.0
  DelayMS 500
  Low PORTA.0
  DelayMS 500
Wend
,
For internal 7.37MHz oscillator with PLL
OSC pins operate as general purpose I/O
,
Config FBS = BWRP_WRPROTTECT_OFF
Config FSS = SWRP_WRPROTTECT_OFF
Config FGS = GWRP_OFF
Config FOSCSEL = FNOSC_FRCPLL, IESO_OFF
Config FOSC = POSCMD_NONE, OSCIOFNC_OFF, IOL1WAY_OFF, FCKSM_CSECME
Config FWDT = WDTPOST_PS256, WINDIS_OFF, FWDTEN_OFF
Config FPOR = FPWRT_PWR128, ALTI2C_OFF
Config FICD = ICS_PGD1, JTAGEN_OFF
```

Example 4

```
' PIC24E internal 7.37MHz oscillator operating at 140.03MHz using PLL
,
    Device = 24EP128MC202
    Declare Xtal = 140.03
,-----
Main:
' Configure the Oscillator to operate the device at 140.03MHz (70 MIPS)
' Fosc = (7.37 * 76) / (2 * 2) = 140.03MHz
,
    PLL_Setup(76, 2, 2, $0300)
,
' Flash an LED connected to PORTA.0
,
    While
        High PORTA.0
        DelayMS 500
        Low PORTA.0
        DelayMS 500
    Wend
,
' For internal 7.37MHz oscillator with PLL
' OSC pins operate as general purpose I/O
,
    Config FGS = GWRP_OFF
    Config FOSCSEL = FNOSC_FRCPLL, IESO_OFF, PWMLOCK_OFF
    Config FOSC = POSCMD_NONE, OSCIOFNC_ON, IOL1WAY_OFF, FCKSM_CSECME
    Config FWDT = WDTPOST_PS256, WINDIS_OFF, PLLKEN_ON, FWDTEN_OFF
    Config FPOR = ALTI2C1_ON, ALTI2C2_OFF
    Config FICD = ICS_PGD1, JTAGEN_OFF
```

Note.

The **PLL_Setup** helper macro can be found within the device's ".def" file. It is required because the dsPIC33[®], PIC24E[®] and PIC24H[®] devices need an unlock sequence before writing to the **OSCCON** SFR, unlike the PIC24F[®] devices, that can write directly to the **OSCCON** SFR.

DelayCs

Syntax

DelayCs *Length*

Overview

Delay execution for an amount of instruction cycles.

Parameters

Length can only be a constant with a value from 1 to 16383.

Example

```
DelayCs 100          ' Delay for 100 cycles
```

Note.

DelayCs is oscillator independent.

The length of a given instruction cycle is determined by the oscillator frequency divided by 2. The higher the oscillator, the smaller the cycle.

See also : **DelayUs**, **DelayMs**.

DelayMs

Syntax

DelayMs *Length*

Overview

Delay execution for *length* x milliseconds (ms). Delays may be up to 65535ms (65.535 seconds) long.

Parameters

Length can be a constant, variable, or expression.

Example

```
Device = 24FJ64GA002
Declare Xtal = 16

Dim MyByte as Byte
Dim MyWord as Word

MyByte = 50
MyWord = 1000
DelayMs 100           ' Delay for 100ms
DelayMs MyByte        ' Delay for 50ms
DelayMs MyWord        ' Delay for 1000ms
DelayMs MyWord + 10   ' Delay for 1010ms
```

Note.

DelayMs is oscillator independent, as long as you inform the compiler of the crystal frequency to use, using the **Xtal** directive.

See also : **DelayCs, DelayUs.**

DelayUs

Syntax

DelayUs *Length*

Overview

Delay execution for *length* x microseconds (us). Delays may be up to 65535us (65.535 milliseconds) long.

Parameters

Length can be a constant, variable, or expression.

Example

```
Device = 24FJ64GA002
```

```
Declare Xtal = 16
```

```
Dim MyByte as Byte
```

```
Dim MyWord as Word
```

```
MyByte = 50
```

```
MyWord = 1000
```

```
DelayUs 1 ' Delay for 1us
```

```
DelayUs 100 ' Delay for 100us
```

```
DelayUs MyByte ' Delay for 50us
```

```
DelayUs MyWord ' Delay for 1000us
```

```
DelayUs MyWord + 10 ' Delay for 1010us
```

Note.

DelayUs is oscillator independent, as long as you inform the compiler of the crystal frequency to use, using the **Xtal** directive.

See also : **DelayUs, DelayMs.**

Device

Syntax

Device *Device name*

Overview

Inform the compiler which microcontroller is being used.

Parameters

Device name can be any value PIC24E, PIC24F, PIC24H, dsPIC33F or dsPIC33E type.

Example

```
Device = 24FJ64GA002      ' Produce code for a 24FJ64GA002 device
```

Device should be the first directive placed in the program.

For an up-to-date list of compatible devices refer to the compiler's PPI folder.

Default location:

For Windows XP or Windows 7 32-bit:

C:\Program Files\ProtonIDE\PDS\Includes\PPI

For Windows 7 64-bit:

C:\Program Files (x86)\ProtonIDE\Includes\PPI

Dig

Syntax

Assignment Variable = **Dig** Value, Digit number

Overview

Returns the value of a decimal digit.

Parameters

Value is an unsigned constant, 8-bit, 16-bit, 32-bit variable or expression, from which the *digit number* is to be extracted.

Digit number is a constant, variable, or expression, that represents the digit to extract from *value*. (0 - 9 with 0 being the rightmost digit).

Example

```
Device = 24FJ64GA002
Declare Xtal = 16
Declare Hserial_Baud = 9600      ' USART1 baud rate
Declare Hrsout1_Pin = PORTB.14  ' Select the pin for TX with USART1

Dim MyByte as Byte
Dim MyResult as Byte

RPOR7 = 3                        ' Make PPS Pin RP14 U1TX

MyByte = 124
MyResult = Dig MyByte, 1 ' Extract the second digit's value
HrsoutLn Dec MyResult     ' Display the value, which is 2
```

Dim

Syntax

Dim *Variable* **as** *Size*

Overview

All user-defined variables must be declared using the **Dim** statement.

Parameters

Variable can be any alphanumeric character or string.

Size is the physical size of the variable, it may be **Bit**, **Byte**, **Word**, **Dword**, **SByte**, **SWord**, **SDword**, **Float**, **Double**, **String**, **Code**, or **PSV**

Example

```
' Declare different sized variables
Dim MyByte as Byte           ' Create an unsigned 8-bit Byte variable
Dim MyWord as Word          ' Create an unsigned 16-bit Word variable
Dim MyDword as Dword        ' Create an unsigned 32-bit Dword variable

Dim sMyByte as SByte        ' Create a signed 8-bit SByte variable
Dim sMyWord as SWord        ' Create a signed 16-bit SWord variable
Dim sMyDword as SDword      ' Create a signed 32-bit SDword variable

Dim MyBit as Bit            ' Create a 1-bit Bit variable
Dim MyFloat as Float        ' Create a 32-bit floating point variable
Dim MyDouble as Double      ' Create a 64-bit floating point variable

Dim MyString as String * 20 ' Create a 20 character string variable
Dim MyCode as Code = 1,2,3,4,5,6,7 ' Place 7 bytes in code memory
Dim MyCode as PSV = 1,2,3,4,5,6,7 ' Place 7 bytes in PSV code memory
```

Notes.

Any RAM variable that is declared without the 'as' text after it, will assume an 8-bit **Byte** type.

Dim should be placed near the beginning of the program. Any references to variables not declared or before they are declared may, in some cases, produce errors.

Variable names, as in the case or labels, may freely mix numeric content and underscores.

```
Dim MyByte as Byte
OR
Dim My_Byte as Word
OR
Dim My_Bit as Bit
```

Variable names may start with an underscore, but must not start with a number. They can be no more than 32 characters long. Any characters after this limit will cause a syntax error.

Dim 2MyVar is **not** allowed.

Variable names are not case sensitive, which means that the variable: -

```
Dim MYVar  
Is the same as...  
Dim MYVar
```

Dim can also be used to create Alias's to other variables: -

```
Dim Var1 as Byte           ' Create a Byte sized variable  
Dim Var_Bit as Var1.1     ' Var_Bit now represents Bit-1 of Var1
```

Alias's, as in the case of constants, do not require any RAM space, because they point to a variable, or part of a variable that has already been declared.

RAM space required.

Each type of variable requires differing amounts of RAM memory for its allocation. The list below illustrates this.

- **String** Requires the specified length of characters + 1.
- **Double** Requires 8 bytes of RAM.
- **Float** Requires 4 bytes of RAM.
- **Dword** Requires 4 bytes of RAM.
- **SDword** Requires 4 bytes of RAM.
- **Word** Requires 2 bytes of RAM.
- **SWord** Requires 2 bytes of RAM.
- **Byte** Requires 1 byte of RAM.
- **SByte** Requires 1 byte of RAM.
- **Bit** Requires 1 byte of RAM for every 8 **Bit** variables declared.

Each type of variable may hold a different minimum and maximum value.

- **String** type variables can hold a maximum of 8192 characters.
- **Bit** type variables may hold a 0 or a 1. These are created 8 at a time, therefore declaring a single **Bit** type variable in a program will not save RAM space, but it will save code space, as **Bit** type variables produce the most efficient use of code for comparisons etc.
- **Byte** type variables may hold an unsigned value from 0 to 255, and are the usual work horses of most programs. Code produced for **Byte** sized variables is very low compared to signed or unsigned **Word**, **DWord** or **Float** types, and should be chosen if the program requires faster, or more efficient operation.
- **SByte** type variables may hold a 2¹⁵ complemented signed value from -128 to +127. Code produced for **SByte** sized variables is very low compared to **SWord**, **Float**, or **SDword** types, and should be chosen if the program requires faster, or more efficient operation. However, code produced is usually larger for signed variables than unsigned types.
- **Word** type variables may hold an unsigned value from 0 to 65535, which is usually large enough for most applications. It still uses more memory than an 8-bit byte variable, but not nearly as much as a **Dword** or **SDword** type.

- **SWord** type variables may hold a 2³¹ complemented signed value from -32768 to +32767, which is usually large enough for most applications. **SWord** type variables will use more code space for expressions and comparisons, therefore, only use signed variables when required.
- **Dword** type variables may hold an unsigned value from 0 to 4294967295 making this the largest of the variable family types. This comes at a price however, as **Dword** calculations and comparisons will use more code space within the microcontroller Use this type of variable sparingly, and only when necessary.
- **SDword** type variables may hold a 2³¹ complemented signed value from -2147483648 to +2147483647, also making this the largest of the variable family types. This comes at a price however, as **SDword** expressions and comparisons will use more code space than a regular **Dword** type. Use this type of variable sparingly, and only when necessary.
- **Float** type variables may theoretically hold a value from -1e37 to +1e38, but because of the 32-bit architecture of the compiler, a maximum and minimum value should be thought of as -2147483646.999 to +2147483646.999 making this the most versatile of the variable family types. However, more so than **Dword** types, this comes at a price as floating point expressions and comparisons will use more code space within the microcontroller. Use this type of variable sparingly, and only when strictly necessary. Smaller floating point values usually offer more accuracy.
- **Double** type variables may hold a value larger than **Float** types, and with some extra accuracy, but because of the 32-bit architecture of the compiler, a maximum and minimum value should be thought of as -2147483646.999 to +2147483646.999 making this one of the most versatile of the variable family types. However, more so than **Dword** and **Float** types, this comes at a price because 64-bit floating point expressions and comparisons will use more code space within the microcontroller. Use this type of variable sparingly, and only when strictly necessary. Smaller floating point values usually offer more accuracy.

There are modifiers that may also be used with variables. These are **HighByte**, **LowByte**, **Byte0**, **Byte1**, **Byte2**, **Byte3**, **Word0**, **Word1**, **HighSByte**, **LowSByte**, **SByte0**, **SByte1**, **SByte2**, **SByte3**, **SWord0**, and **SWord1**,

Word0, **Word1**, **Byte2**, **Byte3**, **SWord0**, **SWord1**, **SByte2**, and **SByte3** may only be used in conjunction with 32-bit **Dword** or **SDword** type variables.

HighByte and **Byte1** are one and the same thing, when used with a **Word** or **SWord** type variable, they refer to the unsigned High byte of a **Word** or **SWord** type variable: -

```
Dim MyWord as Word           ' Create an unsigned Word variable
Dim MyWord_Hi as MyWord.HighByte
' MyWord_Hi now represents the unsigned high byte of variable MyWord
```

Variable **MyWord_Hi** is now accessed as a **Byte** sized type, but any reference to it actually alters the high byte of **MyWord**.

HighSByte and **SByte1** are one and the same thing, when used with a **Word** or **SWord** type variable, they refer to the signed High byte of a **Word** or **SWord** type variable: -

```
Dim MyWord as SWord          ' Create a signed Word variable
Dim MyWord_Hi as MyWord.SByte1
' MyWord_Hi now represents the signed high byte of variable MyWord
```

Variable `MyWord_Hi` is now accessed as an **SByte** sized type, but any reference to it actually alters the high byte of `MyWord`.

However, if **Byte1** is used in conjunction with a **Dword** type variable, it will extract the second byte. **HighByte** will still extract the high byte of the variable, as will **Byte3**. If **SByte1** is used in conjunction with an **SDword** type variable, it will extract the signed second byte. **HighSByte** will still extract the signed high byte of the variable, as will **SByte3**.

The same is true of **LowByte**, **Byte0**, **LowSByte** and **SByte0**, but they refer to the unsigned or signed Low Byte of a **Word** or **SWord** type variable: -

```
Dim MyWord as Word          ' Create an unsigned Word variable
Dim MyWord_Lo as MyWord.LowByte
' MyWord_Lo now represents the low byte of variable MyWord
```

Variable `MyWord_Lo` is now accessed as a **Byte** sized type, but any reference to it actually alters the low byte of `MyWord`.

The modifier **Byte2** will extract the 3rd unsigned byte from a 32-bit **Dword** or **SDword** type variable as an alias. Likewise **Byte3** will extract the unsigned high byte of a 32-bit variable.

```
Dim Dwd as Dword          ' Create a 32-bit unsigned variable named Dwd
Dim Part1 as Dwd.Byte0    ' Alias unsigned Part1 to the low byte of Dwd
Dim Part2 as Dwd.Byte1    ' Alias unsigned Part2 to the 2nd byte of Dwd
Dim Part3 as Dwd.Byte2    ' Alias unsigned Part3 to the 3rd byte of Dwd
Dim Part4 as Dwd.Byte3    ' Alias unsigned Part3 to the high (4th) byte of Dwd
```

The modifier **SByte2** will extract the 3rd signed byte from a 32-bit **Dword** or **SDword** type variable as an alias. Likewise **SByte3** will extract the signed high byte of a 32-bit variable.

```
Dim sDwd as SDword        ' Create a 32-bit signed variable named sDwd
Dim sPart1 as sDwd.SByte0  ' Alias signed Part1 to the low byte of sDwd
Dim sPart2 as sDwd.SByte1  ' Alias signed Part2 to the 2nd byte of sDwd
Dim sPart3 as sDwd.SByte2  ' Alias signed Part3 to the 3rd byte of sDwd
Dim sPart4 as sDwd.SByte3  ' Alias signed Part3 to the 4th byte of sDwd
```

The **Word0** and **Word1** modifiers extract the unsigned low word and high word of a **Dword** or **SDword** type variable, and is used the same as the **Byte***n* modifiers.

```
Dim Dwd as Dword          ' Create a 32-bit unsigned variable named Dwd
Dim Part1 as Dwd.Word0    ' Alias unsigned Part1 to the low word of Dwd
Dim Part2 as Dwd.Word1    ' Alias unsigned Part2 to the high word of Dwd
```

The **SWord0** and **SWord1** modifiers extract the signed low word and high word of a **Dword** or **SDword** type variable, and is used the same as the **SByte**n modifiers.

```
Dim sDwd as SDword      ' Create a 32-bit signed variable named sDwd
Dim sPart1 as sDwd.SWord0 ' Alias Part1 to the low word of sDwd
Dim sPart2 as sDwd.SWord1 ' Alias Part2 to the high word of sDwd
```

Creating Code Memory Tables using Dim

There are two special cases of the Dim directive. These are:

```
Dim MyCode As Code
```

and

```
Dim MyCode As PSV
```

Both will create a data table in the device's code memory, however, the **PSV** directive will ensure that the **AddressOf** function returns the PSV address of the table, instead of its actual code memory address. This used mainly for DSP operations.

The data produced by the Code or PSV directives follows the same casting rules as the Cdata directive, in that the table's data can be given a size that each element will occupy.

```
Dim MyCode as Code = As Word 1, 2, 3, 4, 5
```

or

```
Dim MyCode as PSV = As Dword 100, 200, 300, 400
```

Note.

A code or PSV data table will not be included into a program if it is not used somewhere within the program.

Creating variables in Y RAM

dsPIC33[®] devices have an extra area of RAM dedicated to DSP operations. It resides at the top of the X RAM area and is named Y RAM. All DSP operations involving the accumulators must use Y RAM, otherwise the microcontroller will create an exception.

Adding the text **YRAM** at the end of a variable's declaration will cause it to be created in the Y RAM section:

```
Dim MyArray[10] As Word YRAM = 1, 2, 3, 4, 5, 6, 7
```

Each dsPIC33[®] family has differing amounts of YRAM, so the compiler will produce an error message if the limit is exceeded.

Creating variables in DMA RAM

Some PIC24[®] and dsPIC33[®] devices have an extra area of RAM dedicated to DMA (Direct Memory Access) operations. It resides at the top of the X RAM area, above any Y RAM, and is named DMA RAM. All DMA operations must use DMA RAM, otherwise the microcontroller will create an exception.

Adding the text **DM** at the end of a variable's declaration will cause it to be created in the DMA RAM section:

```
Dim MyArray[10] As Word DMA = 1, 2, 3, 4, 5, 6, 7
```

Each device has differing amounts of DMA RAM, if any, so the compiler will produce an error message if the limit is exceeded.

Notes.

The final RAM usage will also encompass the microcontroller's stack size, therefore, even if the BASIC program only declares 4 byte variables, the final RAM count will be 84. 80 bytes for the default stack size and 4 bytes for variable usage. If handled interrupts are used, the stack size will increase due to context saving and restoring requirements.

RAM locations for variables is allocated automatically within the microcontroller because the PIC24[®] and dsPIC33[®] range of devices have specific requirements concerning RAM addressing. Which are:

- 16-bit variables must be located on a 16-bit RAM address boundary.
- 32-bit and 64-bit variables must be placed on a 16-bit address boundary, but should be placed on a 32-bit address, if possible, for more efficiency with some mnemonics.
- 8-bit variables can be located on an 8-bit, 16-bit or 32-bit RAM address boundary.

Therefore, the order of variable placements is:

- The microcontroller's 16-bit stack is located before all variables are placed.
- The compiler's 16-bit system variables are placed.
- **Word** variables are placed.
- **Dword** variables are placed.
- **Float** variables are placed.
- **Double** variables are placed.
- **Byte** variables are placed.
- **Word Arrays** are placed.
- **Dword Arrays** are placed.
- **Float Arrays** are placed.
- **Byte Arrays** are placed.
- **String** variables are placed.

The logic behind the variable placements is because of the microcontroller's near and far RAM.

The first 8192 bytes of RAM are considered "near" RAM, while space above that is considered "far" RAM. By default, the compiler sets all user variables to near RAM. However, when near RAM space is full, the compiler will place variables in far RAM (above 8192).

The special significance of near versus far to the compiler is that near RAM accesses are encoded in only one mnemonic using direct addressing, while accesses to variables in far RAM require two to three mnemonics using indirect addressing.

Standard variables are used more commonly within a BASIC program, therefore should reside in near RAM for efficiency. Arrays and Strings are generally accessed indirectly anyway, therefore, it is of little consequence if they reside in near or far RAM.

See Also : **Aliases, Declaring Arrays, Floating Point Math, Symbol, Creating and using Strings .**

Do...Loop

Syntax

Do
Instructions
Loop

or

Do
Instructions
Loop Until Condition

or

Do
Instructions
Loop While Condition

Overview

Execute a block of instructions until a condition is true, or while a condition is false, or create an infinite loop.

Example 1

```
Device = 24HJ128GP502
Declare Xtal = 16

Dim MyWord as Word
MyWord = 1
Do                                     ' Create a loop
    Print Dec MyWord, " "
    DelayMs 200
    Inc MyWord
Loop Until MyWord > 10                ' Loop until MyWord is greater than 10
```

Example 2

```
Device = 24HJ128GP502
Declare Xtal = 16

Dim MyWord as Word
MyWord = 1
Do                                     ' Create a loop
    Print Dec MyWord, " "
    DelayMs 200
    Inc MyWord
Loop While MyWord < 11                ' Loop while MyWord is less than 11
```

Example 3

```
Device = 24HJ128GP502
Declare Xtal = 16

Dim MyWord as Word
MyWord = 1
Do                                     ' Create a loop
    Print Dec MyWord, " "
    DelayMs 200
    Inc MyWord
Loop                                   ' Loop forever
```

Notes.

Do-Loop differs from the **While-Wend** type in that, the **Do** loop will carry out the instructions within the loop at least once like a **Repeat-Until** type, then continuously until the condition is true, but the **While** loop only carries out the instructions if the condition is true.

Do-Loop is an ideal replacement to a **For-Next** loop, and can actually take less code space, thus performing the loop faster.

The above example 2 and example 3 show the equivalent to the **For-Next** loop: -

```
For MyWord = 1 to 10 : Next
```

See also : **While...Wend, For...Next...Step.**

DTMFout

Syntax

DTMFout *Pin*, { *OnTime* }, { *OffTime*, } [*Tone* {, *Tone...*}]

Overview

Produce a DTMF Touch Tone sequence on *Pin*.

Parameters

Pin is a Port.Bit constant that specifies the I/O pin to use. This pin will be set to output during generation of tones and set to input after the command is finished.

OnTime is an optional variable, constant, or expression (0 - 65535) specifying the duration, in ms, of the tone. If the *OnTime* parameter is not used, then the default time is 200ms

OffTime is an optional variable, constant, or expression (0 - 65535) specifying the length of silent delay, in ms, after a tone (or between tones, if multiple tones are specified). If the *OffTime* parameter is not used, then the default time is 50ms

Tone may be a variable, constant, or expression (0 - 15) specifying the DTMF tone to generate. Tones 0 through 11 correspond to the standard layout of the telephone keypad, while 12 through 15 are the fourth-column tones used by phone test equipment and in some radio applications.

Example

```
DTMFout PORTA.0, [ 7, 6, 9, 8, 2, 0 ] ' Call a number.
```

If the microcontroller was connected to the phone line correctly, the above command would dial 749990. If you wanted to slow down the dialling in order to break through a noisy phone line or radio link, you could use the optional *OnTime* and *OffTime* values: -

'Set the OnTime to 500ms and OffTime to 100ms

```
DTMFout PORTA.0, 500, 100, [7, 6, 9, 8, 2, 0] ' Call number slowly.
```

Notes. DTMF tones are used to dial a telephone, or remotely control pieces of radio equipment. The microcontroller can generate these tones digitally using the **DTMFout** command. However, to achieve the best quality tones, a higher crystal frequency is required. A 4MHz type will work but the quality of the sound produced will suffer. The circuits illustrate how to connect a speaker or audio amplifier to hear the tones produced.

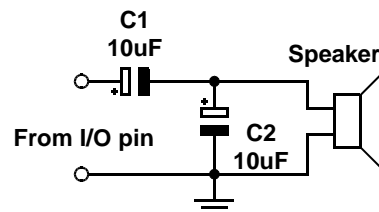
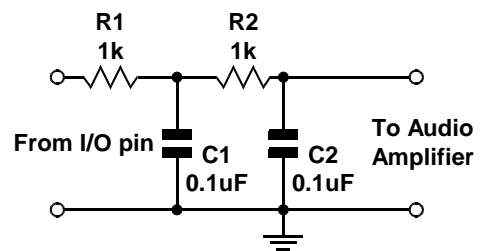

The microcontroller is a digital device, however, DTMF tones are analogue waveforms, consisting of a mixture of two sine waves at different audio frequencies. So how can a digital device generate an analogue output? The microcontroller creates and mixes two sine waves mathematically, then uses the resulting stream of numbers to control the duty cycle of an extremely fast pulse-width modulation (PWM) routine. Therefore, what's actually being produced from the I/O pin is a rapid stream of pulses. The purpose of the filtering arrangements illustrated above is to smooth out the high-frequency PWM, leaving behind only the lower frequency audio. You should keep this in mind if you wish to interface the microcontroller's DTMF output to radios and other equipment that could be adversely affected by the presence of high-frequency noise on the input. Make sure to filter the DTMF output scrupulously. The circuits above are only a reference; you may want to use an active low-pass filter with a cut-off frequency of approximately 2KHz.

Edata

Syntax

Edata *Constant1* { ,...*Constantn* etc }

Overview

Places constants or strings directly into the on-board eeprom memory of compatible devices.

Parameters

Constant1,**Constantn** are values that will be stored in the on-board eeprom. When using an **Edata** statement, all the values specified will be placed in the eeprom starting at location 0. The **Edata** statement does not allow you to specify an eeprom address other than the beginning location at 0. To specify a location to write or read data from the eeprom other than 0 refer to the **Eread**, **Ewrite** commands.

Example

' Stores the values 1000,20,255,15, and the ASCII values for ' H','e','l','l','o' in the eeprom starting at memory position 0.

```
Edata 1000, 20, $FF, %00001111, "Hello"
```

Notes.

16-bit, 32-bit and floating point values may also be placed into eeprom memory. These are placed LSB first (Lowest Significant Byte). For example, if 1000 is placed into an **Edata** statement, then the order is: -

```
Edata 1000
```

In eeprom it looks like 232, 03

Alias's to constants may also be used in an **Edata** statement: -

```
Symbol Alias = 200
```

```
Edata Alias, 120, 254, "Hello World"
```

Addressing an Edata table.

Eeprom data starts at address 0 and works up towards the maximum amount that the micro-controller will allow. However, it is rarely the case that the information stored in eeprom memory is one continuous piece of data. Eeprom memory is normally used for storage of several values or strings of text, so a method of accessing each piece of data is essential. Consider the following piece of code: -

```
Edata "Hello"  
Edata "World"
```

Now we know that eeprom memory starts at 0, so the text "Hello" must be located at address 0, and we also know that the text "Hello" is built from 5 characters with each character occupying a byte of eeprom memory, so the text "World" must start at address 5 and also contains 5 characters, so the next available piece of eeprom memory is located at address 10. To access the two separate text strings we would need to keep a record of the start and end address's of each character placed in the tables.

Counting the amount of eeprom memory used by each piece of data is acceptable if only a few **Edata** tables are used in the program, but it can become tedious if multiple values and strings are needing to be stored, and can lead to program glitches if the count is wrong.

Placing an identifying name before the **Edata** table will allow the compiler to do the byte counting for you. The compiler will store the eeprom address associated with the table in the identifying name as a constant value. For example: -

```
Hello_Text Edata "Hello"  
World_Text Edata "World"
```

The name Hello_Text is now recognised as a constant with the value of 0, referring to address 0 that the text string "Hello" starts at. The World_Text is a constant holding the value 5, which refers to the address that the text string "World" starts at.

Note that the identifying text *must* be located on the same line as the **Edata** directive or a syntax error will be produced. It must also not contain a postfix colon as does a line label or it will be treat as a line label. Think of it as an alias name to a constant.

Any **Edata** directives *must* be placed at the head of the BASIC program as is done with Symbols, so that the name is recognised by the rest of the program as it is parsed. There is no need to jump over **Edata** directives because they do not occupy code memory, but reside in a separate part of memory.

The example program below illustrates the use of eeprom addressing.

```
' Display two text strings held in eeprom memory  
  
Device = 24F08KL301  
Declare Xtal = 16  
Dim Char as Byte          ' Holds the character read from eeprom  
Dim Charpos as Byte       ' Holds the address within eeprom memory  
  
' Create a string of text in eeprom memory. null terminated  
Hello Edata "Hello",0  
' Create another string of text in eeprom memory. null terminated  
World Edata "World",0  
  
DelayMs 100              ' Wait for things to stabilise  
Cls                       ' Clear the LCD  
Charpos = Hello          ' Point Charpos to the start of text "Hello"  
Gosub DisplayText       ' Display the text "Hello"  
Charpos = World          ' Point Charpos to the start of text "World"  
Gosub DisplayText       ' Display the text "World"  
Stop                     ' We're all done  
  
' Subroutine to read and display the text held at the address in Charpos  
DisplayText:  
While                    ' Create an infinite loop  
    Char = Eread Charpos  ' Read the eeprom data  
    If Char = 0 Then Break ' Exit when null found  
    Print Char            ' Display the character  
    Inc Charpos           ' Move up to the next address  
Wend                     ' Close the loop  
Return                   ' Exit the subroutine
```

Formatting an Edata table.

Sometimes it is necessary to create a data table with a known format for its values. For example all values will occupy 4 bytes of data space even though the value itself would only occupy 1 or 2 bytes.

```
Edata 100000, 10000, 1000, 100, 10, 1
```

The above line of code would produce an uneven data space usage, as each value requires a different amount of data space to hold the values. 100000 would require 4 bytes of eeprom space, 10000 and 1000 would require 2 bytes, but 100, 10, and 1 would only require 1 byte.

Reading these values using **Eread** would cause problems because there is no way of knowing the amount of bytes to read in order to increment to the next valid value.

The answer is to use formatters to ensure that a value occupies a predetermined amount of bytes.

These are: -

- Byte**
- Word**
- Dword**
- Float**

Placing one of these formatters at the beginning of the table will force a given length.

```
Edata as Dword 100000, 10000, 1000, 100, 10, 1
```

Byte will force the value to occupy one byte of eeprom space, regardless of its value. Any values above 255 will be truncated to the least significant byte.

Word will force the value to occupy 2 bytes of eeprom space, regardless of its value. Any values above 65535 will be truncated to the two least significant bytes. Any value below 255 will be padded to bring the memory count to 2 bytes.

Dword will force the value to occupy 4 bytes of eeprom space, regardless of its value. Any value below 65535 will be padded to bring the memory count to 4 bytes. The line of code shown above uses the **Dword** formatter to ensure all the values in the **Edata** table occupy 4 bytes of eeprom space.

Float will force a value to its floating point equivalent, which always takes up 4 bytes of eeprom space.

The example below illustrates the formatters in use.

```
' Convert a Dword value into a string array
' Using only BASIC commands
' Similar principle to the Str$ command

Device = 24F08KL301
Declare xtal = 16

Dim P10 as Dword          ' Power of 10 variable
Dim BCount as Byte
Dim Index as Byte

Dim Value as Dword       ' Value to convert
Dim String1[11] as Byte  ' Holds the converted value
Dim Pointer as Byte      ' Pointer within the Byte array

DelayMs 100              ' Wait for things to stabilise
Cls                      ' Clear the LCD
Clear                   ' Clear all RAM before we start
Value = 1234576         ' Value to convert
Gosub DwordToStr        ' Convert Value to string
Print Str String1       ' Display the result
Stop

'-----
' Convert a Dword value into a string array
' Value to convert is placed in 'Value'
' Byte array 'String1' is built up with the ASCII equivalent

DwordToStr:
Pointer = 0
Index = 0
Repeat
P10 = Eread Index * 4
BCount = 0

While Value >= P10
Value = Value - P10
Inc BCount
Wend
If BCount <> 0 Then
String1[Pointer] = BCount + "0"
Inc Pointer
EndIf
Inc Index
Until Index > 8
String1[Pointer] = Value + "0"
Inc Pointer
String1[Pointer] = 0          ' Add the null to terminate the string
Return

' Edata table is formatted for all 32 bit values.
' Which means each value will require 4 bytes of eeprom space
Edata as Dword 100000000, 100000000, 10000000, 1000000, 100000, _
               10000, 1000, 100, 10
```

Label names as pointers in an Edata table.

If a label's name is used in the list of values in an **Edata** table, the labels address will be used. This is useful for accessing other tables of data using their address from a lookup table. See example below.

```
' Display text from two code memory tables
' Based on their address located in a separate table
,
Device = 24F08KL301
Declare Xtal = 16
,
' Table of address's located in eeprom memory
,
Edata as Word String1, String2

Dim DataByte as Byte
Dim String1 as Code = "Hello",0
Dim String2 as Code = "World",0

WREG10 = Eread 0           ' Locate the address of the first string
While                     ' Create an infinite loop
    DataByte = cPtr8(WREG10++) ' Read each character from the code string
    If DataByte = 0 Then Break ' Exit if null found
    Hrsout DataByte          ' Display the character
Wend                       ' Close the loop
Hrsout 13

WREG10 = Eread 2           ' Locate the address of the second string
While                     ' Create an infinite loop
    DataByte = cPtr8(WREG10++) ' Read each character from the code string
    If DataByte = 0 Then Break ' Exit if null found
    Hrsout DataByte          ' Display the character
Wend                       ' Close the loop
Hrsout 13
```

See also : **Eread, Ewrite.**

End

Syntax

End

Overview

The **End** statement creates an infinite loop.

Notes.

End stops the microcontroller processing by placing it into a continuous loop. The port pins remain the same.

See also : **Stop.**

Eread

Syntax

Assignment Variable = **Eread** *Address*

Overview

Read information from the on-board eeprom available on some devices.

Parameters

Assignment Variable is a user defined variable.

Address is a constant, variable, or expression, that contains the address of interest within eeprom memory.

Example

```
Device = 24F08KL301
Declare Xtal = 16

Dim MyByte As Byte
Dim MyWord As Word
Dim MyDword As Dword

Edata 10, 354, 123456789      ' Place some data into the eeprom
MyByte = Eread 0             ' Read the 8-bit value from address 0
MyWord = Eread 1             ' Read the 16-bit value from address 1
MyDword = Eread 3            ' Read the 32-bit value from address 3
```

Notes.

If a **Float**, or **Dword** type variable is used as the assignment variable, then 4-bytes will be read from the eeprom. Similarly, if a **Word** type variable is used as the assignment variable, then a 16-bit value (2-bytes) will be read from eeprom, and if a **Byte** type variable is used, then 8-bits will be read. To read an 8-bit value while using a **Word** sized variable, use the **LowByte** modifier: -

```
MyWord.LowByte = Eread 0      ' Read an 8-bit value
MyWord.HighByte = 0           ' Clear the high byte of MyWord
```

If a 16-bit (**Word**) size value is read from the eeprom, the address must be incremented by two for the next read. Also, if a **Float** or **Dword** type variable is read, then the address must be incremented by 4.

Eeprom memory is non-volatile, and is an excellent place for storage of long-term information, or tables of values.

Reading data with the **Eread** command is almost instantaneous, but writing data to the eeprom can take up to 5ms per byte.

See also : **Edata, Ewrite**

Ewrite

Syntax

Ewrite Address, [Variable {, Variable...etc }]

Overview

Write information to the on-board eeprom available on some devices.

Parameters

Address is a constant, variable, or expression, that contains the address of interest within eeprom memory.

Variable is a user defined variable.

Example

```
Device = 24F08KL301
Declare Xtal = 16

Dim MyByte as Byte
Dim MyWord as Word
Dim Address as Byte
MyByte = 200
MyWord = 2456
Address = 0
Ewrite Address, [MyWord, MyByte] ' Point to address 0 within the eeprom
                                ' Write a 16-bit then an 8-bit value
```

Notes.

If a **Dword** type variable is used, then a 32-bit value (4-bytes) will be written to the eeprom. Similarly, if a **Word** type variable is used, then a 16-bit value (2-bytes) will be written to eeprom, and if a **Byte** type variable is used, then 8-bits will be written. To write an 8-bit value while using a **Word** sized variable, use the **LowByte** modifier: -

```
Ewrite Address, [MyWord.LowByte, MyByte]
```

If a 16-bit (**Word**) size value is written to the eeprom, the address must be incremented by two before the next write: -

```
For Address = 0 to 64 Step 2
    Ewrite Address, [MyWord]
Next
```

Eeprom memory is non-volatile, and is an excellent place for storage of long-term information, or tables of values.

Writing data with the **Ewrite** command can take up to 5ms per byte, but reading data from the eeprom is almost instantaneous,.

See also : **Edata, Eread**

For...Next...Step

Syntax

```
For Variable = Startcount to Endcount [ Step { Stepval } ]  
{code body}  
Next
```

Overview

The **For...Next** loop is used to execute a statement, or series of statements a predetermined amount of times.

Parameters

Variable refers to an index variable used for the sake of the loop. This index variable can itself be used in the code body but beware of altering its value within the loop as this can cause many problems.

Startcount is the start number of the loop, which will initially be assigned to the *variable*. This does not have to be an actual number - it could be the contents of another variable.

Endcount is the number on which the loop will finish. This does not have to be an actual number, it could be the contents of another variable, or an expression.

Stepval is an optional constant or variable by which the *variable* increases or decreases with each trip through the For-Next loop. If *Startcount* is larger than *Endcount*, then a minus sign must precede *Stepval*.

Example 1

```
' Display in decimal, all the values of MyWord within an upward loop  
Device = 24FJ64GA002  
Declare Xtal = 16  
Declare Hserial_Baud = 9600           ' USART1 baud rate  
Declare Hrsout1_Pin = PORTB.14      ' Select the pin for TX with USART1  
  
Dim MyWord as Word  
  
RPOR7 = 3                             ' Make PPS Pin RP14 U1TX  
For MyWord = 0 to 2000 Step 2         ' Perform an upward loop  
    Hrsout Dec MyWord, 13            ' Display the value of MyWord  
Next                                  ' Close the loop
```

Example 2

```
' Display in decimal, all the values of MyWord within a downward loop  
Device = 24FJ64GA002  
Declare Xtal = 16  
Declare Hserial_Baud = 9600           ' USART1 baud rate  
Declare Hrsout1_Pin = PORTB.14      ' Select the pin for TX with USART1  
  
Dim MyWord as Word  
  
RPOR7 = 3                             ' Make PPS Pin RP14 U1TX  
For MyWord = 2000 to 0 Step -2       ' Perform a downward loop  
    Hrsout Dec MyWord, 13            ' Display the value of MyWord  
Next                                  ' Close the loop
```

Example 3

```
' Display in decimal, all the values of MyDword within a downward loop
Device = 24FJ64GA002
Declare Xtal = 16
Declare Hserial_Baud = 9600      ' USART1 baud rate
Declare Hrsout1_Pin = PORTB.14  ' Select the pin for TX with USART1

Dim MyDword as Dword

RPOR7 = 3                        ' Make PPS Pin RP14 U1TX
For MyDword = 200000 to 0 Step -200 ' Perform a downward loop
    Hrsout Dec MyDword, 13        ' Display the value of MyDword
Next                               ' Close the loop
```

Example 4

```
' Display all of MyWord1 using expressions as parts of the For-Next
Device = 24FJ64GA002
Declare Xtal = 16
Declare Hserial_Baud = 9600      ' USART1 baud rate
Declare Hrsout1_Pin = PORTB.14  ' Select the pin for TX with USART1

Dim MyWord1 as Word
Dim MyWord2 as Word

RPOR7 = 3                        ' Make PPS Pin RP14 U1TX
MyWord2 = 1000

For MyWord1= MyWord2 + 10 to MyWord2 + 1000 ' Perform a loop
    Hrsout Dec MyWord1, 13              ' Display the value of MyWord1
Next                                     ' Close the loop
```

Notes.

It may have been noticed from the above examples, that no variable is present after the **Next** command. A variable name after **Next** is purely optional.

For-Next loops may be nested as deeply as the code memory on the microcontroller will allow. To break out of a loop you may use the **GoTo** command without any ill effects, which is exactly what the **Break** command does: -

```
For MyByte = 0 to 20                ' Create a loop of 21
    If MyByte = 10 Then GoTo BreakOut ' Break out of loop when MyByte is 10
Next                                  ' Close the loop
```

BreakOut:

See also : While...Wend, Repeat...Until.

Freqout

Syntax

Freqout *Pin, Period, Freq1* {, *Freq2*}

Overview

Generate one or two sine-wave tones, of differing or the same frequencies, for a specified period.

Parameters

Pin is a Port-Bit combination that specifies which I/O pin to use.

Period may be a variable, constant, or expression (0 - 65535) specifying the amount of time to generate the tone(s).

Freq1 may be a variable, constant, or expression (0 - 32767) specifying frequency of the first tone.

Freq2 may be a variable, constant, or expression (0 - 32767) specifying frequency of the second tone. When specified, two frequencies will be mixed together on the same I/O pin.

Example

' *Generate a 2500Hz (2.5KHz) tone for 1 second (1000 ms) on bit 0 of PORTA.*

```
Freqout PORTA.0, 1000, 2500
```

' *Play two tones at once for 1000ms. One at 2.5KHz, the other at 3KHz.*

```
Freqout PORTA.0, 1000, 2500, 30000
```

Notes.

Freqout generates one or two sine waves using a pulse-width modulation algorithm. **Freqout** will work with a 4MHz crystal, however, it is best used with higher frequency crystals, and operates accurately with a 20MHz or 40MHz crystal. The raw output from **Freqout** requires filtering, to eliminate most of the switching noise. The circuits shown below will filter the signal in order to play the tones through a speaker or audio amplifier.

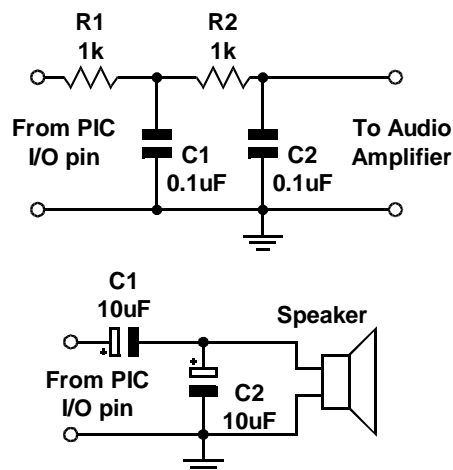

The two circuits shown above, work by filtering out the high-frequency PWM used to generate the sine waves. **Freqout** works over a very wide range of frequencies (0 to 32767KHz) so at the upper end of its range, the PWM filters will also filter out most of the desired frequency. You may need to reduce the values of the parallel capacitors shown in the circuit, or to create an active filter for your application.

Example 2

' Play a tune using Freqout to generate the notes

```
Device = 24FJ64GA002
Declare Xtal = 16

Dim Loop as Byte           ' Counter for notes.
Dim Freq1 as Word         ' Frequency1.
Dim Freq2 as Word         ' Frequency2
Symbol C = 2092           ' C note
Symbol D = 2348           ' D note
Symbol E = 2636           ' E note
Symbol G = 3136           ' G note
Symbol R = 0              ' Silent pause.
Symbol Pin = PORTA.0      ' Sound output pin

Loop = 0
Repeat                     ' Create a loop for 29 notes within the LookUpL table.
    Freq1 = LookUpL Loop, [E,D,C,D,E,E,E,R,D,D,D,_,
                          R,E,G,G,R,E,D,C,D,E,E,E,E,D,D,E,D,C]

    If Freq1 = 0 Then
        Freq2 = 0
    Else
        Freq2 = Freq1 - 8
    EndIf
    Freqout Pin, 225, Freq1, Freq2
    Inc Loop
Until Loop > 28
```

See also : DTMFout, Sound.

GetBit

Syntax

Assignment Variable = **GetBit** *Variable*, *Index*

Overview

Examine a bit of a variable, or register.

Parameters

Assignment Variable is a user defined variable.

Index is a constant, variable, or expression that points to the bit within *Variable* that requires examining.

Example

```
' Examine and display each bit of variable MyByte
Device = 24FJ64GA002
Declare Xtal = 16
Declare Hserial_Baud = 9600      ' USART1 baud rate
Declare Hrsout1_Pin = PORTB.14  ' Select the pin for TX with USART1

Dim MyByte as Byte
Dim Index as Byte
Dim Var1 as Byte

RPOR7 = 3                        ' Make PPS Pin RP14 U1TX

MyByte = %10110111
While                            ' Create an infinite loop
  HrsoutLn Bin8 MyByte           ' Display the original variable
  For Index = 7 to 0 Step -1     ' Create a loop for 8 bits
    Var1 = GetBit MyByte, Index  ' Examine each bit of MyByte
    Hrsout Dec1 Var1             ' Display the binary result
    DelayMs 100                 ' Slow things down to see what's happening
  Next                           ' Close the loop
  Hrsout 13
Wend                             ' Do it forever
```

See also : **ClearBit, LoadBit, SetBit.**

GetPin

Syntax

Assignment Variable = **GetPin** Pin Number

Overview

Examine a pin of a port.

Parameters

Assignment Variable is a user defined variable.

Pin Number is a constant, variable, or expression that points to the pin of a port that requires reading. A value of 0 will read **PORTA.0**, a value of 1 will read **PORTA.1**, a value of 16 will read **PORTB.0** etc... The pin will be made an input before reading commences.

Example

```
' Examine and display each pin of PORTB
Device = 24FJ64GA002
Declare Xtal = 16
Declare Hserial_Baud = 9600      ' USART1 baud rate
Declare Hrsout1_Pin = PORTB.14  ' Select the pin for TX with USART1

Dim PinNumber as Byte
Dim Var1 as Byte

RPOR7 = 3                        ' Make PPS Pin RP14 UITX
While
  For PinNumber = 16 to 31      ' Create a loop for 16 pins
    Var1 = GetPin PinNumber     ' Examine each pin of PORTB
    Hrsout Decl Var1           ' Display the result
  Next                          ' Close the loop
  DelayMs 100                  ' Slow things down to see what's happening
  Hrsout 13
Wend                             ' Do it forever
```

Gosub

Syntax

Gosub *Label*

Overview

Gosub jumps the program to a defined label and continues execution from there. Once the program hits a **Return** command the program returns to the instruction following the **Gosub** that called it and continues execution from that point.

Parameters

Label is a user-defined label.

Example 1

```
' Implement a standard subroutine call
GoTo Main          ' Jump over the subroutines
SubA:
  subroutine A code
  .....
  .....
  Return

SubB:
  subroutine B code
  .....
  .....
  Return

' Actual start of the main program
Main:
  Gosub SubA
  Gosub SubB
```

A subroutine must always end with a **Return** command.

GoTo

Syntax

GoTo *Label*

Overview

Jump to a defined label and continue execution from there.

Parameters

Label is a user-defined label placed at the beginning of a line which must have a colon ':' directly after it.

Example

```
If Var1 = 3 Then GoTo Jumpover  
code here executed only if Var1<>3  
.....  
.....  
JumpOver:  
{continue code execution}
```

In this example, if Var1=3 then the program jumps over all the code below it until it reaches the *label* JumpOver where program execution continues as normal.

See also : **Call, Gosub.**

HbStart

Syntax

HbStart

Overview

Send a **Start** condition to the I²C bus using the microcontroller's MSSP module.

Notes.

Because of the subtleties involved in interfacing to some I²C devices, the compiler's standard **Hbusin** and **Hbusout** commands were found lacking. Therefore, individual pieces of the I²C protocol may be used in association with the new structure of **Hbusin**, and **Hbusout**. See relevant sections for more information.

Example

```
' Interface to a 24LC32 serial eeprom
Device = 24FJ64GA002
Declare Xtal = 16
Declare Hserial_Baud = 9600      ' USART1 baud rate
Declare Hrsout1_Pin = PORTB.14   ' Select the pin for TX with USART1

Dim Loop as Byte
Dim Array[10] as Byte

RPOR7 = 3                        ' Make PPS Pin RP14 U1TX
,
' Transmit bytes to the I2C bus
,
HbStart                          ' Send a Start condition
Hbusout %10100000                ' Target an eeprom, and send a Write command
Hbusout 0                        ' Send the HighByte of the address
Hbusout 0                        ' Send the LowByte of the address
For Loop = 48 to 57              ' Create a loop containing ASCII 0 to 9
    Hbusout Loop                 ' Send the value of Loop to the eeprom
Next                             ' Close the loop
HbStop                          ' Send a Stop condition
DelayMs 10                       ' Wait for the data to be entered into eeprom matrix
,
' Receive bytes from the I2C bus
,
HbStart                          ' Send a Start condition
Hbusout %10100000                ' Target an eeprom, and send a Write command
Hbusout 0                        ' Send the HighByte of the address
Hbusout 0                        ' Send the LowByte of the address
HbRestart                       ' Send a Restart condition
Hbusout %10100001                ' Target an eeprom, and send a Read command
For Loop = 0 to 9                ' Create a loop
    Array[Loop] = Hbusin         ' Load an array with bytes received
    If Loop = 9 Then HbStop : Else : HbusAck ' Ack or Stop ?
Next                             ' Close the loop
HrsoutLn Str Array               ' Display the Array as a String
```

See also : **HbusAck, HbRestart, HbStop, Hbusin, Hbusout.**

HbStop

Syntax
HbStop

Overview

Send a **Stop** condition to the I²C bus using the microcontroller's MSSP module.

HbRestart

Syntax
HbRestart

Overview

Send a **Restart** condition to the I²C bus using the microcontroller's MSSP module.

HbusAck

Syntax
HbusAck

Overview

Send an **Acknowledge** condition to the I²C bus using the microcontroller's MSSP module.

HbusNack

Syntax
HbusNack

Overview

Send a **Not Acknowledge** condition to the I²C bus using the microcontroller's MSSP module..

See also : HbStart, HbRestart, HbStop, Hbusin, Hbusout.

Hbusin

Syntax

Assignment Variable = **Hbusin** *Control*, { *Address* }

or

Assignment Variable = **Hbusin**

or

Hbusin *Control*, { *Address* }, [*Variable* {, *Variable...*}]

or

Hbusin *Variable*

Overview

Receives a value from the I²C bus using the MSSP module, and places it into *variable/s*. If syntax structures *Two* or *Four* (see above) are used, then No Acknowledge, or Stop is sent after the data. Syntax structures *One* and *Three* first send the *control* and optional *address* out of the clock pin (*SCL*), and data pin (*SDA*).

Parameters

Variable is a user defined variable or constant.

Control may be a constant value or a **Byte** sized variable expression.

Address may be a constant value or a variable expression.

The four variations of the **Hbusin** command may be used in the same BASIC program. The *Second* and *Fourth* syntax types are useful for simply receiving a single byte from the bus, and must be used in conjunction with one of the low level commands. i.e. HbStart, HbRestart, HbusAck, or HbStop. The *First*, and *Third* syntax types may be used to receive several values and designate each to a separate variable, or variable type.

The **Hbusin** command operates as an I²C master, using the microcontroller's MSSP module, and may be used to interface with any device that complies with the 2-wire I²C protocol.

The most significant 7-bits of *control* byte contain the control code and the slave address of the device being interfaced with. Bit-0 is the flag that indicates whether a read or write command is being implemented.

For example, if we were interfacing to an external eeprom such as the 24LC32, the control code would be %10100001 or \$A1. The most significant 4-bits (1010) are the eeprom's unique slave address. Bits 2 to 3 reflect the three address pins of the eeprom. And bit-0 is set to signify that we wish to read from the eeprom. Note that this bit is automatically set by the **Hbusin** command, regardless of its initial setting.

Example

' Receive a byte from the I2C bus and place it into variable Var1.

```
Dim MyByte as Byte           ' We'll only read 8-bits
Dim Address as Word          ' 16-bit address required
Symbol Control %10100001    ' Target an eeprom
Address = 20                 ' Read the value at address 20
MyByte = Hbusin Control, Address ' Read the byte from the eeprom
```

or

```
Hbusin Control, Address, [MyByte] ' Read the byte from the eeprom
```

Address, is an optional parameter that may be an 8-bit or 16-bit value. If a variable is used in this position, the size of *address* is dictated by the size of the variable used (**Byte** or **Word**). In the case of the previous eeprom interfacing, the 24LC32 eeprom requires a 16-bit address. While the smaller types require an 8-bit address. Make sure you assign the right size address for the device interfaced with, or you may not achieve the results you intended.

The value received from the bus depends on the size of the variables used, except for variation three, which only receives a **Byte** (8-bits). For example: -

```
Dim MyWord as Word          ' Create a Word size variable
MyWord = Hbusin Control, Address
```

Will receive a 16-bit value from the bus. While: -

```
Dim MyByte as Byte         ' Create a Byte size variable
MyByte = Hbusin Control, Address
```

Will receive an 8-bit value from the bus.

Using the *Third* variation of the **Hbusin** command allows differing variable assignments. For example: -

```
Dim MyByte as Byte
Dim MyWord as Word
Hbusin Control, Address, [MyByte, MyWord]
```

Will receive two values from the bus, the first being an 8-bit value dictated by the size of variable *MyByte* which has been declared as a byte. And a 16-bit value, this time dictated by the size of the variable *MyWord* which has been declared as a word. Of course, **Bit** type variables may also be used, but in most cases these are not of any practical use as they still take up a byte within the eeprom.

The *Second* and *Fourth* syntax variations allow all the subtleties of the I²C protocol to be exploited, as each operation may be broken down into its constituent parts. It is advisable to refer to the datasheet of the device being interfaced to fully understand its requirements. See section on **HbStart**, **HbRestart**, **HbusAck**, or **HbStop**, for example code.

Hbusin Declares

Declare **HSDA_Pin** Port . Pin

Declares the port and pin used for the data line (SDA). The location of the port and pin used for hardware I²C can be altered by the fuse configurations. If the declare is not used in the program, it will default to the standard pin configuration.

Declare **HSCL_Pin** Port . Pin

Declares the port and pin used for the clock line (SCL). The location of the port and pin used for hardware I²C can be altered by the fuse configurations. If the declare is not used in the program, it will default to the standard pin configuration.

Declare **Hbus_Bitrate** Constant 100, 400, 1000 etc.

The standard speed for the I²C bus is 100KHz. Some devices use a higher bus speed of 400KHz. The above **Declare** allows the I²C bus speed to be increased or decreased. Use this **Declare** with caution, as too high a bit rate may exceed the device's specs, which will result in intermittent transactions, or in some cases, no transactions at all. The datasheet for the device used will inform you of its bus speed. The default bit rate is the standard 100KHz.

Notes.

Because the I²C protocol calls for an *open-collector* interface, pull-up resistors are required on both the SDA and SCL lines. Values of 1K Ω to 4.7K Ω will suffice.

Str modifier with Hbusin

Using the **Str** modifier allows variations *Three* and *Four* of the **Hbusin** command to transfer the bytes received from the I²C bus directly into a byte array. If the amount of received characters is not enough to fill the entire array, then a formatter may be placed after the array's name, which will only receive characters until the specified length is reached. An example of each is shown below: -

```
Dim MyArray[10] as Byte      ' Create an array of 10 bytes
Dim Address as Byte         ' Create a word sized variable

Hbusin %10100000, Address, [Str MyArray] ' Load data into all the array
,
' Load data into only the first 5 elements of the array
,
Hbusin %10100000, Address, [Str MyArray\5]
HbStart                    ' Send a Start condition
Hbusout %10100000          ' Target an eeprom, and send a WRITE command
Hbusout 0                  ' Send the HighByte of the address
Hbusout 0                  ' Send the LowByte of the address
HbRestart                 ' Send a Restart condition
Hbusout %10100001         ' Target an eeprom, and send a Read command
Hbusin Str MyArray        ' Load all the array with bytes received
HbStop                    ' Send a Stop condition
```

An alternative ending to the above example is: -

```
Hbusin Str MyArray\5      ' Load data into only the first 5 elements of array
HbStop                   ' Send a Stop condition
```

See also : HbusAck, HbRestart, HbStop, HbStart, Hbusout.

Hbusout

Syntax

Hbusout *Control*, { *Address* }, [*Variable* {, *Variable...*}]

or

Hbusout *Variable*

Overview

Transmit a value to the I²C bus using the microcontroller's on-board MSSP module, by first sending the *control* and optional *address* out of the clock pin (*SCL*), and data pin (*SDA*). Or alternatively, if only one operator is included after the **Hbusout** command, a single value will be transmitted, along with an Ack reception.

Parameters

Variable is a user defined variable or constant.

Control may be a constant value or a **Byte** sized variable expression.

Address may be a constant, variable, or expression.

The **Hbusout** command operates as an I²C master and may be used to interface with any device that complies with the 2-wire I²C protocol.

The most significant 7-bits of *control* byte contain the control code and the slave address of the device being interfaced with. Bit-0 is the flag that indicates whether a read or write command is being implemented.

For example, if we were interfacing to an external eeprom such as the 24LC32, the control code would be %10100000 or \$A0. The most significant 4-bits (1010) are the eeprom's unique slave address. Bits 2 to 3 reflect the three address pins of the eeprom. And Bit-0 is clear to signify that we wish to write to the eeprom. Note that this bit is automatically cleared by the **Hbusout** command, regardless of its initial value.

Example

' Send a byte to the I2C bus.

```
Dim MyByte as Byte           ' We'll only read 8-bits
Dim Address as Word          ' 16-bit address required
Symbol Control = %10100000  ' Target an eeprom

Address = 20                  ' Write to address 20
MyByte = 200                  ' The value place into address 20
Hbusout Control, Address, [MyByte] ' Send the byte to the eeprom
DelayMs 10                    ' Allow time for allocation of byte
```

Address, is an optional parameter that may be an 8-bit or 16-bit value. If a variable is used in this position, the size of *address* is dictated by the size of the variable used (**Byte** or **Word**). In the case of the above eeprom interfacing, the 24LC32 eeprom requires a 16-bit address. While the smaller types require an 8-bit address. Make sure you assign the right size address for the device interfaced with, or you may not achieve the results you intended.

The value sent to the bus depends on the size of the variables used. For example: -

```
Dim MyWord as Word      ' Create a Word size variable
Hbusout Control, Address, [MyWord]
```

Will send a 16-bit value to the bus. While: -

```
Dim MyByte as Byte     ' Create a Byte size variable
Hbusout Control, Address, [MyByte]
```

Will send an 8-bit value to the bus.

Using more than one variable within the brackets allows differing variable sizes to be sent. For example: -

```
Dim MyByte as Byte
Dim MyWord as Word
Hbusout Control, Address, [MyByte, MyWord]
```

Will send two values to the bus, the first being an 8-bit value dictated by the size of variable Var1 which has been declared as a byte. And a 16-bit value, this time dictated by the size of the variable MyWord which has been declared as a word. Of course, **Bit** type variables may also be used, but in most cases these are not of any practical use as they still take up a byte within the eeprom.

A string of characters can also be transmitted, by enclosing them in quotes: -

```
Hbusout Control, Address, ["Hello World", MyByte, MyWord]
```

Using the second variation of the **Hbusout** command, necessitates using the low level commands i.e. **HbStart**, **HbRestart**, **HbusAck**, or **HbStop**.

Using the **Hbusout** command with only one value after it, sends a byte of data to the I²C bus, and returns holding the Acknowledge reception. This acknowledge indicates whether the data has been received by the slave device.

The Ack reception is returned in the microcontroller's CARRY flag, which is SR.0, and also System variable PP4.0. A value of zero indicates that the data was received correctly, while a one indicates that the data was not received, or that the slave device has sent a NAck return. You must read and understand the datasheet for the device being interfacing to, before the Ack return can be used successfully. An code snippet is shown below: -

```
' Transmit a byte to a 24LC32 serial eeprom
HbStart      ' Send a Start condition
Hbusout %10100000 ' Target an eeprom, and send a Write command
Hbusout 0    ' Send the HighByte of the address
Hbusout 0    ' Send the LowByte of the address
Hbusout "A"  ' Send the value 65 to the bus
If SRbits_C = 1 Then GoTo Not_Received ' Has Ack been received OK?
HbStop      ' Send a Stop condition
DelayMs 10  ' Wait for the data to be entered into eeprom matrix
```

Hbusout Declares

Declare HSDA_Pin Port . Pin

Declares the port and pin used for the data line (SDA). The location of the port and pin used for hardware I²C can be altered by the fuse configurations. If the declare is not used in the program, it will default to the standard pin configuration.

Declare HSCL_Pin Port . Pin

Declares the port and pin used for the clock line (SCL). The location of the port and pin used for hardware I²C can be altered by the fuse configurations. If the declare is not used in the program, it will default to the standard pin configuration.

Declare Hbus_Bitrate Constant 100, 400, 1000 etc.

The standard speed for the I²C bus is 100KHz. Some devices use a higher bus speed of 400KHz. The above **Declare** allows the I²C bus speed to be increased or decreased. Use this **Declare** with caution, as too high a bit rate may exceed the device's specs, which will result in intermittent transactions, or in some cases, no transactions at all. The datasheet for the device used will inform you of its bus speed. The default bit rate is the standard 100KHz.

Notes.

When the **Hbusout** command is used, the appropriate SDA and SCL Port and Pin are automatically setup as inputs. Because the I²C protocol calls for an *open-collector* interface, pull-up resistors are required on both the SDA and SCL lines. Values of 1K Ω to 4.7K Ω will suffice.

Str modifier with Hbusout.

The **Str** modifier is used for transmitting a string of bytes from a byte array variable. A string is a set of bytes sized values that are arranged or accessed in a certain order. The values 1, 2, 3 would be stored in a string with the value 1 first, followed by 2 then followed by the value 3. A byte array is a similar concept to a string; it contains data that is arranged in a certain order. Each of the elements in an array is the same size. The string 1,2,3 would be stored in a byte array containing three bytes (elements).

Below is an example that sends four bytes from an array: -

```
Dim MyArray[10] as Byte      ' Create a 10-byte array.
MyArray [0] = "A"           ' Load the first 4 bytes of the array
MyArray [1] = "B"           ' With the data to send
MyArray [2] = "C"
MyArray [3] = "D"
Hbusout %10100000, Address, [Str MyArray \4] ' Send 4-byte string.
```

Note that we use the optional \n argument of **Str**. If we didn't specify this, the program would try to keep sending characters until all 10 bytes of the array were transmitted. Since we do not wish all 10 bytes to be transmitted, we chose to tell it explicitly to only send the first 4 bytes.

The above example may also be written as: -

```
Dim MyArray[10] as Byte      ' Create a 10-byte array.
Str MyArray = "ABCD"         ' Load the first 4 bytes of the array

HbStart                       ' Send a Start condition
Hbusout %10100000             ' Target an eeprom, and send a Write command
Hbusout 0                     ' Send the HighByte of the address
Hbusout 0                     ' Send the LowByte of the address
Hbusout Str MyArray\4         ' Send 4-byte string.
HbStop                       ' Send a Stop condition
```

The above example, has exactly the same function as the previous one. The only differences are that the string is now constructed using the **Str** as a command instead of a modifier, and the low-level Hbus commands have been used.

See also : HbusAck, HbRestart, HbStop, Hbusin, HbStart.

High

Syntax

High *Port* or *Port.Bit* or *Pin Number*

Overview

Place a Port or Port.Pin in a high output state. For a Port, this means setting it as an output and filling it with 1's.

Parameters

Port can be any valid port.

Port.Bit can be any valid port and bit combination, i.e. **PORTA.1**

Pin Number can be a variable or constant that holds a value from 0 to the amount of I/O pins on the device. A value of 0 will be **PORTA.0**, if present, 1 will be **PORTA.1**, 16 will be **PORTB.0** etc...

Example 1

```
Device = 24HJ128GP502
Declare Xtal = 16
```

```
Symbol LED = PORTB.4
High LED
```

```
High PORTB
High PORTA.0
```

```
High 1           ' Set Pin PORTA.1 high
```

Example 2

```
' Flash each of the pins on PORTB
```

```
Device = 24HJ128GP502
Declare Xtal = 16
```

```
Dim MyPin as Byte
```

```
For MyPin = 16 to 31           ' Create a loop for the pin to flash (PORTB)
  High MyPin                   ' Set the pin high
  DelayMs 500                   ' Delay so that it can be seen
  Low MyPin                     ' Pull the pin low
  DelayMs 500                   ' Delay so that it can be seen
```

```
Next
```

Notes.

The compiler will write to the device's **LAT** SFR and will always set the relevant Port or Port.Bit to an output.

Each pin number has a designated name. These are Pin_A0, Pin_A1, Pin_A2, Pin_B0...Pin_B15, Pin_C0...Pin_C15, Pin_D0...Pin_D15 to Pin_L15 etc... Each of the names has a relevant value, for example, Pin_A0 has the value 0, Pin_B0 has the value 16, up to Pin_J15, which has the value 143.

These can be used to pass a relevant pin number to a Procedure. For example:

```
,
' Flash an LED attached to PORTB.0 via a procedure
' Then flash an LED attached to PORTB.1 via the same procedure
,
Device = 24HJ128GP502
Declare Xtal = 16

Do                                ' Create a loop
    FlashPin(Pin_B0)              ' Call the procedure to flash PORTB.0
    FlashPin(Pin_B1)              ' Call the procedure to flash PORTB.1
Loop                                ' Do it forever
,
' Set a pin high then low for 500ms using a variable as the pin to adjust
,
Proc FlashPin(pPinNumber As Byte)
    High pPinNumber                ' Set the pin output high
    DelayMs 500                    ' Wait for 500 milliseconds
    Low pPinNumber                 ' Pull the pin output low
    DelayMs 500                    ' Wait for 500 milliseconds
EndProc
```

Example 3

```
' Clear then Set each pin of PORTC
Device = 24HJ128GP502
Declare Xtal = 16

Dim PinNumber as Byte

Low PORTC                          ' Make PORTC output low before we start
Do                                  ' Create a loop
    For PinNumber = Pin_C0 to Pin_C7 ' Create a loop for 8 pins
        Low PinNumber                ' Clear each pin of PORTC
        DelayMs 100                  ' Slow things down to see what's happening
    Next                              ' Close the loop
    For PinNumber = Pin_C0 to Pin_C7 ' Create a loop for 8 pins
        High PinNumber               ' Set each pin of PORTC
        DelayMs 100                  ' Slow things down to see what's happening
    Next                              ' Close the loop
Loop                                  ' Do it forever
```

See also : **Clear, Dim, Low, Set, SetPin, Symbol.**

Hpwm

Syntax

Hpwm Channel, DutyCycle, Frequency

Overview

Output a pulse width modulated pulse train using on of the OCP modules. The PWM pulses produced can run continuously in the background while the program is executing other instructions.

Parameters

Channel is a constant value that specifies which hardware PWM channel to use (1 to 5). must be the same on all channels. It must be noted, that this is a limitation of the devices not the compiler. The data sheet for the particular device used shows the fixed hardware pin for each Channel.

DutyCycle is a variable, constant (0-255), or expression that specifies the on/off (high/low) ratio of the signal. It ranges from 0 to 255, where 0 is off (low all the time) and 255 is on (high) all the time. A value of 127 gives a 50% duty cycle (square wave).

Frequency is a variable, constant (0-65535), or expression that specifies the desired frequency of the PWM signal. Not all frequencies are available at all oscillator settings. The highest frequency at any oscillator speed is 65535Hz. The lowest usable **Hpwm Frequency** at each oscillator setting is dependant on the oscillator frequency that the device is operating with.

Example

```
Device = 24FJ64GA002
Declare Xtal = 32

CLKDIV = 0           ' CPU peripheral clock ratio set to 1:1
Write_OSCCONH(%00010000) ' Enable PLL

Hpwm 1,127,1000      ' Send a 50% duty cycle PWM signal at 1KHz
DelayMs 500
Hpwm 1,64,2000       ' Send a 25% duty cycle PWM signal at 2KHz
,
' For internal oscillator with PLL
,

Config Config1 = JTAGEN_OFF, GCP_OFF, GWRP_OFF, BKBUG_OFF, COE_OFF, _
                ICS_PGx1, FWDTEN_OFF, WINDIS_OFF, FWPSA_PR128, WDTPOST_PS256
Config Config2 = IOL1WAY_OFF, COE_OFF, IESO_OFF, FNOSC_FRCPLL, _
                FCKSM_CSDCMD, OSCIOFNC_ON, POSCMOD_NONE
```

Notes.

Some devices have alternate pins that may be used for **Hpwm**. The following **Declares** allow the use of different pins: -

```
Declare CCP1_Pin Port.Pin ' Select Hpwm port and bit for OCP1 module.
Declare CCP2_Pin Port.Pin ' Select Hpwm port and bit for OCP2 module.
Declare CCP3_Pin Port.Pin ' Select Hpwm port and bit for OCP3 module.
Declare CCP4_Pin Port.Pin ' Select Hpwm port and bit for OCP4 module.
Declare CCP5_Pin Port.Pin ' Select Hpwm port and bit for OCP5 module.
```

See also : **Pwm, Pulseout, Servo.**

Hrsin, Hrsin2, Hrsin3, Hrsin4

Syntax

Assignment Variable = **Hrsin**, { *Timeout*, *Timeout Label* }

or

Hrsin { *Timeout*, *Timeout Label* }, { *Parity Error Label* }, *Modifiers*, *Variable* {, *Variable...* }

Overview

Receive one or more values from the serial port on devices that contain a hardware USART.

Parameters

Timeout is an *optional* value for the length of time the **Hrsin** command will wait before jumping to label **Timeout Label**. **Timeout** is specified in 1 millisecond units.

Timeout Label is an *optional* valid BASIC label where **Hrsin** will jump to in the event that a character has not been received within the time specified by **Timeout**.

Parity Error Label is an *optional* valid BASIC label where **Hrsin** will jump to in the event that a Parity error is received. Parity is set using **Declares**. Parity Error detecting is not supported in the inline version of **Hrsin** (first syntax example above).

Modifier is one of the many formatting modifiers, explained below.

Assignment Variable is a user variable, that will be loaded by **Hrsin**.

Example

```
' Receive values serially and timeout if no reception after 1 second
,
Device = 24FJ64GA002
Declare Xtal = 32
Declare Hserial_Baud = 9600      ' USART1 baud rate
Declare Hrsout1_Pin = PORTB.14  ' Select the pin for TX with USART1
Declare HRSIn1_Pin = PORTB.15   ' Select the pin for RX with USART1

Dim MyByte as Byte

CLKDIV = 0                       ' CPU peripheral clock ratio set to 1:1
Write_OSCCONH(%00010000)        ' Enable PLL
RPOR7 = 3                        ' Make RP14(PORTB.14) the pin for UART1 TX
RPINR18 = 15                     ' Make RP15(PORTB.15) the pin for UART1 RX

Do
  MyByte = Hrsin, {1000, Timeout}' Receive a byte serially into MyByte
  HrsoutLn Dec MyByte           ' Re-Transmit the byte received
Loop                            ' Loop forever
Timeout:
  HrsoutLn "Timed Out"         ' Transmit an error if Hrsin timed out
Stop
,
' For internal oscillator with PLL
,
Config Config1 = JTAGEN_OFF, GCP_OFF, GWRP_OFF, BKBUG_OFF, COE_OFF, _
                ICS_PGx1, FWDTEN_OFF, WINDIS_OFF, FWPSA_PR128, WDTPOST_PS256
Config Config2 = IOL1WAY_OFF, COE_OFF, IESO_OFF, FNOSC_FRCPLL, _
                FCKSM_CSDCMD, OSCIOFNC_ON, POSCMOD_NONE
```

Hrsin Modifiers.

As we already know, **Rsin** will wait for and receive a single byte of data, and store it in a variable. If the microcontroller was connected to a PC running a terminal program and the user pressed the "A" key on the keyboard, after the **Hrsin** command executed, the variable would contain 65, which is the ASCII code for the letter "A"

What would happen if the user pressed the "1" key? The result would be that the variable would contain the value 49 (the ASCII code for the character "1"). This is an important point to remember: every time you press a character on the keyboard, the computer receives the ASCII value of that character. It is up to the receiving side to interpret the values as necessary. In this case, perhaps we actually wanted the variable to end up with the value 1, rather than the ASCII code 49.

The **Hrsin** command provides a modifier, called the decimal modifier, which will interpret this for us. Look at the following code: -

```
Dim SerData as Byte
Hrsin Dec SerData
```

Notice the decimal modifier in the **Hrsin** command that appears just to the left of the SerData variable. This tells **Hrsin** to convert incoming text representing decimal numbers into true decimal form and store the result in SerData. If the user running the terminal software pressed the "1", "2" and then "3" keys followed by a space or other non-numeric text, the value 123 will be stored in the variable SerData, allowing the rest of the program to perform any numeric operation on the variable.

Without the decimal modifier, however, you would have been forced to receive each character ("1", "2" and "3") separately, and then would still have to do some manual conversion to arrive at the number 123 (one hundred twenty three) before you can do the desired calculations on it.

The decimal modifier is designed to seek out text that represents decimal numbers. The characters that represent decimal numbers are the characters "0" through "9". Once the **Hrsin** command is asked to use the decimal modifier for a particular variable, it monitors the incoming serial data, looking for the first decimal character. Once it finds the first decimal character, it will continue looking for more (accumulating the entire multi-digit number) until it finds a non-decimal numeric character. Remember that it will not finish until it finds at least one decimal character followed by at least one non-decimal character.

To illustrate this further, examine the following examples (assuming we're using the same code example as above): -

Serial input: "ABC"

Result: The program halts at the **Hrsin** command, continuously waiting for decimal text.

Serial input: "123" (with no characters following it)

Result: The program halts at the **Hrsin** command. It recognises the characters "1", "2" and "3" as the number one hundred twenty three, but since no characters follow the "3", it waits continuously, since there's no way to tell whether 123 is the entire number or not.

Serial input: "123" (followed by a space character)

Result: Similar to the above example, except once the space character is received, the program knows the entire number is 123, and stores this value in SerData. The **Hrsin** command then ends, allowing the next line of code to run.

Serial input: "123A"

Result: Same as the example above. The "A" character, just like the space character, is the first non-decimal text after the number 123, indicating to the program that it has received the entire number.

Serial input: "ABCD123EFGH"

Result: Similar to examples 3 and 4 above. The characters "ABCD" are ignored (since they're not decimal text), the characters "123" are evaluated to be the number 123 and the following character, "E", indicates to the program that it has received the entire number.

The final result of the **Dec** modifier is limited to 16 bits (up to the value 65535). If a value larger than this is received by the decimal modifier, the end result will be incorrect because the result rolled-over the maximum 16-bit value. Therefore, **Hrsin** modifiers may not (at this time) be used to load **Dword** (32-bit) variables.

The decimal modifier is only one of a family of conversion modifiers available with **Hrsin**. See below for a list of available conversion modifiers. All of the conversion modifiers work similar to the decimal modifier (as described above). The modifiers receive bytes of data, waiting for the first byte that falls within the range of characters they accept (e.g., "0" or "1" for binary, "0" to "9" for decimal, "0" to "9" and "A" to "F" for hex). Once they receive a numeric character, they keep accepting input until a non-numeric character arrives, or in the case of the fixed length modifiers, the maximum specified number of digits arrives.

While very effective at filtering and converting input text, the modifiers aren't completely fool-proof. As mentioned before, many conversion modifiers will keep accepting text until the first non-numeric text arrives, even if the resulting value exceeds the size of the variable. After **Hrsin**, a **Byte** variable will contain the lowest 8 bits of the value entered and a **Word** (16-bits) would contain the lowest 16 bits. You can control this to some degree by using a modifier that specifies the number of digits, such as **Dec2**, which would accept values only in the range of 0 to 99.

Conversion Modifier	Type of Number Numeric	Characters Accepted
Dec {1..10}	Decimal, optionally limited to 1 - 10 digits	0 through 9
Hex {1..8}	Hexadecimal, optionally limited to 1 - 8 digits	0 through 9, A through F
Bin {1..32}	Binary, optionally limited to 1 - 32 digits	0, 1

A variable preceded by **Bin** will receive the ASCII representation of its binary value. For example, if **Bin** Var1 is specified and "1000" is received, Var1 will be set to 8.

A variable preceded by **Dec** will receive the ASCII representation of its decimal value. For example, if **Dec** Var1 is specified and "123" is received, Var1 will be set to 123.

A variable preceded by **Hex** will receive the ASCII representation of its hexadecimal value. For example, if **Hex** Var1 is specified and "FE" is received, Var1 will be set to 254.

SKIP followed by a count will skip that many characters in the input stream. For example, **SKIP** 4 will skip 4 characters.

The **Hrsin** command can be configured to wait for a specified sequence of characters before it retrieves any additional input. For example, suppose a device attached to the microcontroller is known to send many different sequences of data, but the only data you wish to observe happens to appear right after the unique characters, "XYZ". A modifier named **Wait** can be used for this purpose: -

```
Hrsin Wait("XYZ"), SerData
```

The above code waits for the characters "X", "Y" and "Z" to be received, in that order, then it receives the next data byte and places it into variable SerData.

Str modifier.

The **Hrsin** command also has a modifier for handling a string of characters, named **Str**.

The **Str** modifier is used for receiving a string of characters into a byte array variable.

A string is a set of characters that are arranged or accessed in a certain order. The characters "ABC" would be stored in a string with the "A" first, followed by the "B" then followed by the "C". A byte array is a similar concept to a string; it contains data that is arranged in a certain order. Each of the elements in an array is the same size. The string "ABC" would be stored in a byte array containing three bytes (elements).

Below is an example that receives ten bytes and stores them in the 10-byte array, SerString: -

```
Dim SerString[10] as Byte      ' Create a 10-byte array.
Hrsin Str SerString           ' Fill the array with received data.
Print Str SerString           ' Display the string.
```

If the amount of received characters is not enough to fill the entire array, then a formatter may be placed after the array's name, which will only receive characters until the specified length is reached. For example: -

```
Dim SerString[10] as Byte      ' Create a 10-byte array.
Hrsin Str SerString\5          ' Fill the first 5-bytes of the array
Print Str SerString\5          ' Display the 5-character string.
```

The example above illustrates how to fill only the first n bytes of an array, and then how to display only the first n bytes of the array. n refers to the value placed after the backslash.

Because of its complexity, serial communication can be rather difficult to work with at times. Using the guidelines below when developing a project using the **Hrsin** and **Hrsout** commands may help to eliminate some obvious errors: -

Always build your project in steps.

Start with small, manageable pieces of code, (that deal with serial communication) and test them, one individually.

Add more and more small pieces, testing them each time, as you go.

Never write a large portion of code that works with serial communication without testing its smallest workable pieces first.

Pay attention to timing.

Be careful to calculate and overestimate the amount of time, operations should take within the microcontroller for a given oscillator frequency. Misunderstanding the timing constraints is the source of most problems with code that communicate serially. If the serial communication in your project is bi-directional, the above statement is even more critical.

Pay attention to wiring.

Take extra time to study and verify serial communication wiring diagrams. A mistake in wiring can cause strange problems in communication, or no communication at all. Make sure to connect the ground pins (Vss) between the devices that are communicating serially.

Verify port setting on the PC and in the Hrsin / Hrsout commands.

Unmatched settings on the sender and receiver side will cause garbled data transfers or no data transfers. This is never more critical than when a line transceiver is used(i.e. MAX232). Always remember that a line transceiver inverts the serial polarity.

If the serial data received is unreadable, it is most likely caused by a baud rate setting error, or a polarity error.

If receiving data from another device that is not a microcontroller, try to use baud rates of 9600 and below, or alternatively, use a higher frequency crystal.

Because of additional overheads in the microcontroller, and the fact that the **Hrsin** command only offers a 8 level receive buffer for serial communication, received data may sometimes be missed or garbled. If this occurs, try lowering the baud rate, or increasing the crystal frequency. Using simple variables (not arrays) will also increase the chance that the microcontroller will receive the data properly.

Declares

There are several Declare directives for use with the **Hrsin** commands. These are: -

Declare **HRsin_Pin** Port . Pin

Declares the port and pin used for USART1 reception (RX). The location of the port and pin is dictated by the device's PPS (Peripheral Pin Select) options. Note that this declare will not alter any PPS (Peripheral Pin Select) SFRs.

Declare **Hserial_Baud** Constant value

Sets the Baud rate that will be used to receive a value serially from USART1. The baud rate is calculated using the **Xtal** frequency declared in the program. The default baud rate if the Declare is not included in the program listing is 9600 baud.

Declare **Hserial_Parity** Odd or Even

Enables/Disables parity on the serial port. For both **Hrsin** and **Hrsout** The default serial data format is 8N1, 8 data bits, no parity bit and 1 stop bit. 7E1 (7 data bits, even parity, 1 stop bit) or 7O1 (7data bits, odd parity, 1 stop bit) may be enabled using the **Hserial_Parity** declare.

```
Declare Hserial_Parity = Even      ' Use if even parity desired
Declare Hserial_Parity = Odd       ' Use if odd parity desired
```

Declare **Hserial_Clear** On or Off

Clear the overflow error bit before commencing a read.

The hardware serial ports (USARTs) only have a small input buffer, therefore, they can easily overflow if characters are not read from it often enough. When this occurs, USART1 stops accepting any new characters, and requires resetting. This overflow error can be reset by clearing the OERR bit within the **U1STA** register:

```
Clear U1STAbits_OERR      ' Clear an overflow error for USART1
```

Alternatively, the **Hserial_Clear** declare can be used to automatically clear this error, even if no error occurred. However, the program will not know if an error occurred while reading, therefore some characters may be lost.

```
Declare Hserial_Clear = On
```

Declare **HRsin2_Pin** Port . Pin

Declares the port and pin used for USART2 reception (RX). The location of the port and pin is dictated by the device's PPS (Peripheral Pin Select) options. Note that this declare will not alter any PPS (Peripheral Pin Select) SFRs.

Declare **Hserial2_Baud** Constant value

Sets the Baud rate that will be used to receive a value serially from USART2. The baud rate is calculated using the **Xtal** frequency declared in the program. The default baud rate if the Declare is not included in the program listing is 9600 baud.

Declare **Hserial2_Parity** Odd or Even

Enables/Disables parity on the serial port. For both **Hrsin2** and **Hrsout2** The default serial data format is 8N1, 8 data bits, no parity bit and 1 stop bit. 7E1 (7 data bits, even parity, 1 stop bit) or 7O1 (7data bits, odd parity, 1 stop bit) may be enabled using the **Hserial2_Parity** declare.

```
Declare Hserial2_Parity = Even      ' Use if even parity desired  
Declare Hserial2_Parity = Odd       ' Use if odd parity desired
```

Declare **Hserial2_Clear** On or Off

Clear the overflow error bit before commencing a read.

The hardware serial ports (USARTs) only have a small input buffer, therefore, they can easily overflow if characters are not read from it often enough. When this occurs, USART2 stops accepting any new characters, and requires resetting. This overflow error can be reset by clearing the OERR bit within the **U2STA** register:

```
Clear U2STAbits_OERR      ' Clear an overflow error for USART2
```

Alternatively, the **Hserial2_Clear** declare can be used to automatically clear this error, even if no error occurred. However, the program will not know if an error occurred while reading, therefore some characters may be lost.

```
Declare Hserial2_Clear = On
```

Declare **HRsin3_Pin** Port . Pin

Declares the port and pin used for USART3 reception (RX). The location of the port and pin is dictated by the device's PPS (Peripheral Pin Select) options. Note that this declare will not alter any PPS (Peripheral Pin Select) SFRs.

Declare **Hserial3_Baud** Constant value

Sets the Baud rate that will be used to receive a value serially from USART3. The baud rate is calculated using the **Xtal** frequency declared in the program. The default baud rate if the Declare is not included in the program listing is 9600 baud.

Declare **Hserial3_Parity** Odd or Even

Enables/Disables parity on the serial port. For both **Hrsin3** and **Hrsout3** The default serial data format is 8N1, 8 data bits, no parity bit and 1 stop bit. 7E1 (7 data bits, even parity, 1 stop bit) or 7O1 (7data bits, odd parity, 1 stop bit) may be enabled using the **Hserial3_Parity** declare.

```
Declare Hserial3_Parity = Even    ' Use if even parity desired  
Declare Hserial3_Parity = Odd     ' Use if odd parity desired
```

Declare **Hserial3_Clear** On or Off

Clear the overflow error bit before commencing a read.

The hardware serial ports (USARTs) only have a small input buffer, therefore, they can easily overflow if characters are not read from it often enough. When this occurs, USART3 stops accepting any new characters, and requires resetting. This overflow error can be reset by clearing the OERR bit within the U3STA register:

```
Clear U3STAbits_OERR ' Clear an overflow error for USART3
```

Alternatively, the **Hserial3_Clear** declare can be used to automatically clear this error, even if no error occurred. However, the program will not know if an error occurred while reading, therefore some characters may be lost.

```
Declare Hserial3_Clear = On
```

Declare **HRsin4_Pin** Port . Pin

Declares the port and pin used for USART4 reception (RX). The location of the port and pin is dictated by the device's PPS (Peripheral Pin Select) options. Note that this declare will not alter any PPS (Peripheral Pin Select) SFRs.

Declare **Hserial4_Baud** Constant value

Sets the Baud rate that will be used to receive a value serially from USART4. The baud rate is calculated using the **Xtal** frequency declared in the program. The default baud rate if the Declare is not included in the program listing is 9600 baud.

Declare **Hserial4_Parity** Odd or Even

Enables/Disables parity on the serial port. For both **Hrsin4** and **Hrsout4** The default serial data format is 8N1, 8 data bits, no parity bit and 1 stop bit. 7E1 (7 data bits, even parity, 1 stop bit) or 7O1 (7data bits, odd parity, 1 stop bit) may be enabled using the **Hserial4_Parity** declare.

```
Declare Hserial4_Parity = Even    ' Use if even parity desired  
Declare Hserial4_Parity = Odd     ' Use if odd parity desired
```

Declare **Hserial4_Clear** On or Off

Clear the overflow error bit before commencing a read.

The hardware serial ports (USARTs) only have a small input buffer, therefore, they can easily overflow if characters are not read from it often enough. When this occurs, USART4 stops accepting any new characters, and requires resetting. This overflow error can be reset by clearing the OERR bit within the **U4STA** register:

```
Clear U4STAbits_OERR ' Clear an overflow error for USART4
```

Alternatively, the **Hserial4_Clear** declare can be used to automatically clear this error, even if no error occurred. However, the program will not know if an error occurred while reading, therefore some characters may be lost.

```
Declare Hserial4_Clear = On
```

Notes.

The **Hrsin** commands can only be used with devices that contain a hardware USART. See the specific device's data sheet for further information concerning the serial input pin as well as other relevant parameters.

See also : **Declare, Rsin, Rsout, Hrsout, Hserin, Hserout.**

Hrsout, Hrsout2, Hrsout3, Hrsout4

Syntax

Hrsout *Item* {, *Item*... }

Overview

Transmit one or more *Items* from a USART on devices that support asynchronous serial communications in hardware.

Parameters

Item may be a constant, variable, expression, string list, or inline command.

There are no operands as such, instead there are *modifiers*. For example, if an at sign '@' precedes an *Item*, the ASCII representation for each digit is transmitted.

The modifiers are listed below: -

Modifier	Operation
Bin {1..32}	Send binary digits
Dec {1..10}	Send decimal digits
Hex {1..8}	Send hexadecimal digits
Sbin {1..32}	Send signed binary digits
Sdec {1..10}	Send signed decimal digits
Shex {1..8}	Send signed hexadecimal digits
Ibin {1..32}	Send binary digits with a preceding '%' identifier
Idec {1..10}	Send decimal digits with a preceding '#' identifier
Ihex {1..8}	Send hexadecimal digits with a preceding '\$' identifier
ISbin {1..32}	Send signed binary digits with a preceding '%' identifier
ISdec {1..10}	Send signed decimal digits with a preceding '#' identifier
IShex {1..8}	Send signed hexadecimal digits with a preceding '\$' identifier
Rep c\n	Send character c repeated n times
Str array\n	Send all or part of an array
Cstr Label	Send string data defined in code memory.

The numbers after the **Bin**, **Dec**, and **Hex** modifiers are optional. If they are omitted, then the default is all the digits that make up the value will be displayed.

If a floating point variable is to be displayed, then the digits after the **Dec** modifier determine how many remainder digits are send. i.e. numbers after the decimal point.

```
Dim MyFloat as Float
MyFloat = 3.145
Hrsout Dec2 MyFloat ' Send 2 digits after the decimal point
```

The above program will transmit the ASCII characters "3.14"

If the digit after the **Dec** modifier is omitted, then 3 digits will be displayed after the decimal point.

```
Dim MyFloat as Float
MyFloat = 3.1456
Hrsout Dec MyFloat      ' Send 3 digits after the decimal point
```

The above program will transmit the ASCII characters "3.145"

There is no need to use the **Sdec** modifier for signed floating point values, as the compiler's **Dec** modifier will automatically display a minus result: -

```
Dim MyFloat as Float
MyFloat = -3.1456
Hrsout Dec MyFloat      ' Send 3 digits after the decimal point
```

The above program will transmit the ASCII characters "-3.145"

Example 1

```
Device = 24FJ64GA002
Declare Xtal = 32
Declare Hserial_Baud = 9600      ' USART1 baud rate
Declare Hrsout1_Pin = PORTB.14  ' Select the pin for TX with USART1

Dim MyByte as Byte
Dim MyWord as Word
Dim MyDword as Dword

CLKDIV = 0                      ' CPU peripheral clock ratio set to 1:1
Write_OSCCONH(%00010000)       ' Enable PLL
RPOR7 = 3                       ' Make RP14(PORTB.14) the pin for UART1 TX

Hrsout "Hello World\r"         ' Display the text "Hello World"
Hrsout "Var1= ", Dec MyByte, 13 ' Display the decimal value of MyByte
Hrsout "Var1= ", Hex MyByte, 13 ' Display the hexadecimal value of MyByte
Hrsout "Var1= ", Bin MyByte, 13 ' Display the binary value of MyByte
Hrsout "MyDword= ", Hex6 MyDword, 13 ' Display 6 hex characters

' For internal oscillator with PLL
,

Config Config1 = JTAGEN_OFF, GCP_OFF, GWRP_OFF, BKBUG_OFF, COE_OFF, _
                ICS_PGx1, FWDTEN_OFF, WINDIS_OFF, FWPSA_PR128, WDTPOST_PS256
Config Config2 = IOL1WAY_OFF, COE_OFF, IESO_OFF, FNOSC_FRCPLL, _
                FCKSM_CSDCMD, OSCIOFNC_ON, POSCMOD_NONE
```

The **Cstr** modifier may be used in commands that deal with text processing i.e. **Serout**, **Hserout**, and **Print** etc. However, the **Cstr** keyword is not always required, because the compiler recognises a label name as a null terminated string of characters.

The **Cstr** modifier can be used in conjunction with code memory strings. The **Dim as Code** directive is used for initially creating the string of characters: -

```
Dim MyCodeString as Code = "Hello World", 0
```

The above line of code will create, in code memory, the values that make up the ASCII text "Hello World", at address MyCodeString. Note the null terminator after the ASCII text. Null terminated means that a zero (null) is placed at the end of the string of ASCII characters to signal that the string has finished.

To display, or transmit this string of characters, the following command structure could be used:

```
Hrsout MyCodeString
```

The label that declared the address where the list of code memory values resided, now becomes the code memory string's name. For example, to transmit using a code memory string: -

```
Device = 24FJ64GA002
Declare Xtal = 32
Declare Hserial_Baud = 9600      ' USART1 baud rate
Declare Hrsout1_Pin = PORTB.14  ' Select the pin for TX with USART1

Dim Text1 as Code = "Hello World\r", 0
Dim Text2 as Code = "How are you?\r", 0
Dim Text3 as Code = "I am fine!\r", 0

CLKDIV = 0                      ' CPU peripheral clock ratio set to 1:1
Write_OSCCONH(%00010000)       ' Enable PLL
RPOR7 = 3                       ' Make PPS Pin RP14 U1TX

Hrsout Text1
Hrsout Text2
Hrsout Text3
,
' For internal oscillator with PLL
,
Config Config1 = JTAGEN_OFF, GCP_OFF, GWRP_OFF, BKBUG_OFF, COE_OFF, _
                ICS_PGx1, FWDTEN_OFF, WINDIS_OFF, FWPSA_PR128, WDTPOST_PS256
Config Config2 = IOL1WAY_OFF, COE_OFF, IESO_OFF, FNOSC_FRCPLL, _
                FCKSM_CSDCMD, OSCIOFNC_ON, POSCMOD_NONE
```

Note the null terminators after the ASCII text in the code memory strings. Without these, the device will continue to transmit data until it sees a value of 0.

Internally, the compiler is placing the quoted strings of characters into code memory, therefore either of the above constructs is valid, however, the compiler also internally combines quoted strings that are identical, meaning that the first of the above constructs can be more efficient in some cases.

The **Str** modifier is used for sending a string of bytes from a byte array variable. A string is a set of bytes sized values that are arranged or accessed in a certain order. The values 1, 2, 3 would be stored in a string with the value 1 first, followed by 2 then followed by the value 3. A byte array is a similar concept to a string; it contains data that is arranged in a certain order. Each of the elements in an array is the same size. The string 1,2,3 would be stored in a byte array containing three bytes (elements).

Below is an example that displays four bytes (from a byte array): -

```
Dim MyArray[10] as Byte      ' Create a 10-byte array.
MyArray [0] = "H"           ' Load the first 5 bytes of the array
MyArray [1] = "e"           ' With the data to send
MyArray [2] = "l"
MyArray [3] = "l"
MyArray [4] = "o"
Hrsout Str MyArray\5        ' Display a 5-byte string.
```

Note that we use the optional \n argument of **Str**. If we didn't specify this, the microcontroller would try to keep sending characters until all 10 bytes of the array were transmitted. Since we do not wish all 10 bytes to be transmitted, we chose to tell it explicitly to only send the first 5 bytes.

The above example may also be written as: -

```
Dim MyArray [10] as Byte    ' Create a 10-byte array.
Str MyArray = "Hello"       ' Load the first 5 bytes of the array
Hrsout Str MyArray\5        ' Send 5-byte string.
```

The above example, has exactly the same function as the previous one. The only difference is that the string is now constructed using **Str** as a command instead of a modifier.

Declares

There are several **Declare** directives for use with the **Hrsout** commands. These are: -

For HRsOut

Declare HRsout_Pin Port . Pin

Declares the port and pin used for USART1 transmission (TX). The location of the port and pin is dictated by the device's PPS (Peripheral Pin Select) options. Note that this declare will not alter any PPS (Peripheral Pin Select) SFRs.

There is no default setting for this **Declare** and it must be used within the BASIC program.

Declare Hserial_Baud Constant value

Sets the BAUD rate that will be used to transmit a value serially. The baud rate is calculated using the **Xtal** frequency declared in the program. The default baud rate if the Declare is not included in the program listing is 2400 baud.

Declare Hserial_Parity Odd or Even

Enables/Disables parity on the serial port. For both **Hrsout** and **Hrsin** The default serial data format is 8N1, 8 data bits, no parity bit and 1 stop bit. 7E1 (7 data bits, even parity, 1 stop bit) or 7O1 (7data bits, odd parity, 1 stop bit) may be enabled using the **Hserial_Parity** declare.

```
Declare Hserial_Parity = Even    ' Use if even parity desired
Declare Hserial_Parity = Odd     ' Use if odd parity desired
```

Declare Hrsout_Pace 0 to 65535 microseconds (us)

Implements a delay between characters transmitted by the **Hrsout** command.

On occasion, the characters transmitted serially are in a stream that is too fast for the receiver to catch, this results in missed characters. To alleviate this, a delay may be implemented between each individual character transmitted by **Hrsout**.

If the **Declare** is not used in the program, then the default is no delay between characters.

For HRsout2

Declare HRsout2_Pin Port . Pin

Declares the port and pin used for USART2 transmission (TX). The location of the port and pin is dictated by the device's PPS (Peripheral Pin Select) options. Note that this declare will not alter any PPS (Peripheral Pin Select) SFRs.

There is no default setting for this **Declare** and it must be used within the BASIC program.

Declare Hserial2_Baud Constant value

Sets the BAUD rate that will be used to transmit a value serially. The baud rate is calculated using the **Xtal** frequency declared in the program.

Declare Hserial2_Parity Odd or Even

Enables/Disables parity on the serial port. For both **Hrsout2** and **Hrsin2** The default serial data format is 8N1, 8 data bits, no parity bit and 1 stop bit. 7E1 (7 data bits, even parity, 1 stop bit) or 7O1 (7 data bits, odd parity, 1 stop bit) may be enabled using the **Hserial2_Parity** declare.

```
Declare Hserial2_Parity = Even      ' Use if even parity desired
Declare Hserial2_Parity = Odd       ' Use if odd parity desired
```

Declare Hrsout2_Pace 0 to 65535 microseconds (us)

Implements a delay between characters transmitted by the **Hrsout2** command.

On occasion, the characters transmitted serially are in a stream that is too fast for the receiver to catch, this results in missed characters. To alleviate this, a delay may be implemented between each individual character transmitted by **Hrsout2**.

If the **Declare** is not used in the program, then the default is no delay between characters.

For HRsout3

Declare HRsout3_Pin Port . Pin

Declares the port and pin used for USART3 transmission (TX). The location of the port and pin is dictated by the device's PPS (Peripheral Pin Select) options. Note that this declare will not alter any PPS (Peripheral Pin Select) SFRs.

There is no default setting for this **Declare** and it must be used within the BASIC program.

Declare Hserial3_Baud Constant value

Sets the BAUD rate that will be used to transmit a value serially. The baud rate is calculated using the **Xtal** frequency declared in the program.

Declare **Hserial3_Parity** Odd or Even

Enables/Disables parity on the serial port. For both **Hrsout3** and **Hrsin3** The default serial data format is 8N1, 8 data bits, no parity bit and 1 stop bit. 7E1 (7 data bits, even parity, 1 stop bit) or 7O1 (7data bits, odd parity, 1 stop bit) may be enabled using the **Hserial3_Parity** declare.

```
Declare Hserial3_Parity = Even      ' Use if even parity desired
Declare Hserial3_Parity = Odd      ' Use if odd parity desired
```

Declare **Hrsout3_Pace** 0 to 65535 microseconds (us)

Implements a delay between characters transmitted by the **HRsout3** command.

On occasion, the characters transmitted serially are in a stream that is too fast for the receiver to catch, this results in missed characters. To alleviate this, a delay may be implemented between each individual character transmitted by **Hrsout3**.

If the **Declare** is not used in the program, then the default is no delay between characters.

For **HRsout4**

Declare **HRsout4_Pin** Port . Pin

Declares the port and pin used for USART4 transmission (TX). The location of the port and pin is dictated by the device's PPS (Peripheral Pin Select) options. Note that this declare will not alter any PPS (Peripheral Pin Select) SFRs.

There is no default setting for this **Declare** and it must be used within the BASIC program.

Declare **Hserial4_Baud** Constant value

Sets the BAUD rate that will be used to transmit a value serially. The baud rate is calculated using the **Xtal** frequency declared in the program.

Declare **Hserial4_Parity** Odd or Even

Enables/Disables parity on the serial port. For both **Hrsout4** and **Hrsin4** The default serial data format is 8N1, 8 data bits, no parity bit and 1 stop bit. 7E1 (7 data bits, even parity, 1 stop bit) or 7O1 (7data bits, odd parity, 1 stop bit) may be enabled using the **Hserial4_Parity** declare.

```
Declare Hserial4_Parity = Even      ' Use if even parity desired
Declare Hserial4_Parity = Odd      ' Use if odd parity desired
```

Declare **Hrsout4_Pace** 0 to 65535 microseconds (us)

Implements a delay between characters transmitted by the **Hrsout4** command.

On occasion, the characters transmitted serially are in a stream that is too fast for the receiver to catch, this results in missed characters. To alleviate this, a delay may be implemented between each individual character transmitted by **Hrsout4**.

If the **Declare** is not used in the program, then the default is no delay between characters.

Notes.

The **Hrsout commands** can only be used with devices that contain a hardware USART. See the specific device's data sheet for further information concerning the serial input pin as well as other relevant parameters.

See also : **Declare, Rsin, Rsout, Serin, Serout, Hrsin, Hserin, Hserout.**

HrsoutLn, Hrsout2Ln, Hrsout3Ln, Hrsout4Ln

Syntax

HrsoutLn *Item* {, *Item*... }

Hrsout2Ln *Item* {, *Item*... }

Hrsout3Ln *Item* {, *Item*... }

Hrsout4Ln *Item* {, *Item*... }

Overview

Transmit one or more *Items* from the hardware serial port on devices that contain one or more USART peripherals and terminate with a Carriage Return(13) or Carriage Return(13) Line Feed(10) or Line Feed(10) Carriage Return(13). The syntax and operators are exactly the same as **Hrsout**, **Hrsout2**, **Hrsout3** and **Hrsout4**. If **Hrsout2Ln**, **Hrsout3Ln**, or **Hrsout4Ln** are used, the device must contain more than 1 USART.

Parameters

Item may be a constant, variable, expression, string list, or inline command.

There are no operators as such, instead there are *modifiers*. See the section for **Hrsout** for more details.

Declares

There are 4 declares for the HrsoutXLn commands. Each one is for the particular command.

```
Declare Hserial1_Terminator = CRLF or LFCR or CR
```

```
Declare Hserial2_Terminator = CRLF or LFCR or CR
```

```
Declare Hserial3_Terminator = CRLF or LFCR or CR
```

```
Declare Hserial4_Terminator = CRLF or LFCR or CR
```

The parameter **CR** will transmit a single value of 13 at the end of transmission.

The parameter **CRLF** will transmit a value of 13 then 10 at the end of transmission.

The parameter **LFCR** will transmit a value of 10 then 13 at the end of transmission.

See also : **Declare**, **Rsin**, **Rsout**, **Serin**, **Serout**, **Hrsout**, **Hrsin**, **Hserin**, **Hserout**.

Hserin, Hserin2, Hserin3, Hserin4

Syntax

Hserin *Timeout*, *Timeout Label*, *Parity Error Label*, [*Modifiers*, *Variable* {, *Variable...* }]

Overview

Receive one or more values from the serial port on devices that contain a hardware USART. (Compatible with the melabs compiler)

Parameters

Timeout is an *optional* value for the length of time the **Hserin** command will wait before jumping to label **Timeout Label**. **Timeout** is specified in 1 millisecond units.

Timeout Label is an optional valid BASIC label where **Hserin** will jump to in the event that a character has not been received within the time specified by **Timeout**.

Parity Error Label is an optional valid BASIC label where **Hserin** will jump to in the event that a Parity error is received. Parity is set using **Declares**. Parity Error detecting is not supported in the inline version of **Hserin** (first syntax example above).

Modifier is one of the many formatting modifiers, explained below.

Variable is a **Bit**, **Byte**, **Word**, or **Dword** variable, that will be loaded by **Hserin**.

Example

```
' Receive values serially and timeout if no reception after 1 second
Device = 24FJ64GA002
Declare Xtal = 32
Declare Hserial_Baud = 9600           ' USART1 baud rate
Declare Hrsout1_Pin = PORTB.14       ' Select the pin for TX with USART1
Declare Hrsout1_Pin = PORTB.15       ' Select the pin for RX with USART1

Dim MyByte as Byte

CLKDIV = 0                           ' CPU peripheral clock ratio set to 1:1
Write_OSCCONH(%00010000)             ' Enable PLL
RPOR7 = 3                             ' Make RP14(PORTB.14) the pin for UART1 TX
RPINR18 = 15                          ' Make RP15(PORTB.15) the pin for UART1 RX

Do
    Hserin 1000, Timeout, [MyByte]     ' Receive a byte serially into MyByte
    Hrsout Dec MyByte                  ' Re-Transmit the byte received
Loop                                   ' Loop forever
Timeout:
    HrsoutLn "Timed Out"               ' Transmit an error if Hserin timed out
'
' For internal oscillator with PLL
'
Config Config1 = JTAGEN_OFF, GCP_OFF, GWRP_OFF, BKBUG_OFF, COE_OFF, _
                ICS_PGx1, FWDTEN_OFF, WINDIS_OFF, FWPSA_PR128, WDTPOST_PS256
Config Config2 = IOL1WAY_OFF, COE_OFF, IESO_OFF, FNOSC_FRCPLL, _
                FCKSM_CSDCMD, OSCIOFNC_ON, POSCMOD_NONE
```

Hserin Modifiers.

As we already know, **Hserin** will wait for and receive a single byte of data, and store it in a variable . If the microcontroller was connected to a PC running a terminal program and the user pressed the "A" key on the keyboard, after the **Hserin** command executed, the variable would contain 65, which is the ASCII code for the letter "A"

What would happen if the user pressed the "1" key? The result would be that the variable would contain the value 49 (the ASCII code for the character "1"). This is an important point to remember: every time you press a character on the keyboard, the computer receives the ASCII value of that character. It is up to the receiving side to interpret the values as necessary. In this case, perhaps we actually wanted the variable to end up with the value 1, rather than the ASCII code 49.

The **Hserin** command provides a modifier, called the decimal modifier, which will interpret this for us. Look at the following code: -

```
Dim SerData as Byte
Hserin [Dec SerData]
```

Notice the decimal modifier in the **Hserin** command that appears just to the left of the SerData variable. This tells **Hserin** to convert incoming text representing decimal numbers into true decimal form and store the result in SerData. If the user running the terminal software pressed the "1", "2" and then "3" keys followed by a space or other non-numeric text, the value 123 will be stored in the variable SerData, allowing the rest of the program to perform any numeric operation on the variable.

Without the decimal modifier, however, you would have been forced to receive each character ("1", "2" and "3") separately, and then would still have to do some manual conversion to arrive at the number 123 (one hundred twenty three) before you can do the desired calculations on it.

The decimal modifier is designed to seek out text that represents decimal numbers. The characters that represent decimal numbers are the characters "0" through "9". Once the **Hserin** command is asked to use the decimal modifier for a particular variable, it monitors the incoming serial data, looking for the first decimal character. Once it finds the first decimal character, it will continue looking for more (accumulating the entire multi-digit number) until it finds a non-decimal numeric character. Remember that it will not finish until it finds at least one decimal character followed by at least one non-decimal character.

To illustrate this further, examine the following examples (assuming we're using the same code example as above): -

Serial input: "ABC"

Result: The program halts at the **Hserin** command, continuously waiting for decimal text.

Serial input: "123" (with no characters following it)

Result: The program halts at the **Hserin** command. It recognises the characters "1", "2" and "3" as the number one hundred twenty three, but since no characters follow the "3", it waits continuously, since there's no way to tell whether 123 is the entire number or not.

Serial input: "123" (followed by a space character)

Result: Similar to the above example, except once the space character is received, the program knows the entire number is 123, and stores this value in SerData. The **Hserin** command then ends, allowing the next line of code to run.

Serial input: "123A"

Result: Same as the example above. The "A" character, just like the space character, is the first non-decimal text after the number 123, indicating to the program that it has received the entire number.

Serial input: "ABCD123EFGH"

Result: Similar to examples 3 and 4 above. The characters "ABCD" are ignored (since they're not decimal text), the characters "123" are evaluated to be the number 123 and the following character, "E", indicates to the program that it has received the entire number.

The final result of the **Dec** modifier is limited to 16 bits (up to the value 65535). If a value larger than this is received by the decimal modifier, the end result will be incorrect because the result rolled-over the maximum 16-bit value. Therefore, **Hserin** modifiers may not (at this time) be used to load **Dword** (32-bit) variables.

The decimal modifier is only one of a family of conversion modifiers available with **Hserin**. See below for a list of available conversion modifiers. All of the conversion modifiers work similar to the decimal modifier (as described above). The modifiers receive bytes of data, waiting for the first byte that falls within the range of characters they accept (e.g., "0" or "1" for binary, "0" to "9" for decimal, "0" to "9" and "A" to "F" for hex). Once they receive a numeric character, they keep accepting input until a non-numeric character arrives, or in the case of the fixed length modifiers, the maximum specified number of digits arrives.

While very effective at filtering and converting input text, the modifiers aren't completely fool-proof. As mentioned before, many conversion modifiers will keep accepting text until the first non-numeric text arrives, even if the resulting value exceeds the size of the variable. After **Hserin**, a **Byte** variable will contain the lowest 8 bits of the value entered and a **Word** (16-bits) would contain the lowest 16 bits. You can control this to some degree by using a modifier that specifies the number of digits, such as **Dec2**, which would accept values only in the range of 0 to 99.

Conversion Modifier	Type of Number	Numeric	Characters Accepted
Dec {1..10}	Decimal, optionally limited to 1 - 10 digits		0 through 9
Hex {1..8}	Hexadecimal, optionally limited to 1 - 8 digits		0 through 9, A through F
Bin {1..32}	Binary, optionally limited to 1 - 32 digits		0, 1

A variable preceded by **Bin** will receive the ASCII representation of its binary value. For example, if **Bin** Var1 is specified and "1000" is received, Var1 will be set to 8.

A variable preceded by **Dec** will receive the ASCII representation of its decimal value. For example, if **Dec** Var1 is specified and "123" is received, Var1 will be set to 123.

A variable preceded by **Hex** will receive the ASCII representation of its hexadecimal value. For example, if **Hex** Var1 is specified and "FE" is received, Var1 will be set to 254.

Skip followed by a count will skip that many characters in the input stream. For example, **Skip** 4 will skip 4 characters.

The **Hserin** command can be configured to wait for a specified sequence of characters before it retrieves any additional input. For example, suppose a device attached to the microcontroller is known to send many different sequences of data, but the only data you wish to observe happens to appear right after the unique characters, "XYZ". A modifier named **Wait** can be used for this purpose: -

```
Hserin [Wait("XYZ"), SerData]
```

The above code waits for the characters "X", "Y" and "Z" to be received, in that order, then it receives the next data byte and places it into variable SerData.

Str modifier.

The **Hserin** command also has a modifier for handling a string of characters, named **Str**.

The **Str** modifier is used for receiving a string of characters into a byte array variable.

A string is a set of characters that are arranged or accessed in a certain order. The characters "ABC" would be stored in a string with the "A" first, followed by the "B" then followed by the "C". A byte array is a similar concept to a string; it contains data that is arranged in a certain order. Each of the elements in an array is the same size. The string "ABC" would be stored in a byte array containing three bytes (elements).

Below is an example that receives ten bytes and stores them in the 10-byte array, SerString: -

```
Dim SerString[10] as Byte      ' Create a 10-byte array.
Hserin [Str SerString]        ' Fill the array with received data.
HrsoutLn Str SerString        ' Display the string.
```

If the amount of received characters is not enough to fill the entire array, then a formatter may be placed after the array's name, which will only receive characters until the specified length is reached. For example: -

```
Dim SerString[10] as Byte      ' Create a 10-byte array.
Hserin [Str SerString\5]      ' Fill the first 5-bytes of the array
Hrsout Str SerString\5        ' Display the 5-character string.
```

The example above illustrates how to fill only the first n bytes of an array, and then how to display only the first n bytes of the array. n refers to the value placed after the backslash.

Because of its complexity, serial communication can be rather difficult to work with at times. Using the guidelines below when developing a project using the **Hserin** and **Hserout** commands may help to eliminate some obvious errors: -

Always build your project in steps.

Start with small, manageable pieces of code, (that deal with serial communication) and test them, one individually.

Add more and more small pieces, testing them each time, as you go.

Never write a large portion of code that works with serial communication without testing its smallest workable pieces first.

Pay attention to timing.

Be careful to calculate and overestimate the amount of time, operations should take within the microcontroller for a given oscillator frequency. Misunderstanding the timing constraints is the source of most problems with code that communicate serially. If the serial communication in your project is bi-directional, the above statement is even more critical.

Pay attention to wiring.

Take extra time to study and verify serial communication wiring diagrams. A mistake in wiring can cause strange problems in communication, or no communication at all. Make sure to connect the ground pins (Vss) between the devices that are communicating serially.

Verify port setting on the PC and in the Hserin / Hserout commands.

Unmatched settings on the sender and receiver side will cause garbled data transfers or no data transfers. This is never more critical than when a line transceiver is used(i.e. MAX232). Always remember that a line transceiver inverts the serial polarity.

If the serial data received is unreadable, it is most likely caused by a baud rate setting error, or a polarity error.

If receiving data from another device that is not a microcontroller, try to use baud rates of 9600 and below, or alternatively, use a higher frequency crystal.

Because of additional overheads in the microcontroller, and the fact that the **Hserin** command offers a 8 level hardware receive buffer for serial communication, received data may sometimes be missed or garbled. If this occurs, try lowering the baud rate, or increasing the crystal frequency. Using simple variables (not arrays) will also increase the chance that the microcontroller will receive the data properly.

Declares

There are several Declare directives for use with the **Hserin** commands. These are the same declares as used by the **HRsin** commands

Notes.

The **Hserin commands** can only be used with devices that contain a hardware USART. See the specific device's data sheet for further information concerning the serial input pin as well as other relevant parameters.

See also : Declare, Hserout, Hrsin, Hrsout, Rsin, Rsout.

Hserout, Hserout2, Hserout3, Hserout4

Syntax

Hserout [*Item* {, *Item*... }]

Overview

Transmit one or more *Items* from the USART on devices that support asynchronous serial communications in hardware.

Parameters

Item may be a constant, variable, expression, string list, or inline command.

There are no operands as such, instead there are *modifiers*. For example, if an at sign '@' precedes an *Item*, the ASCII representation for each digit is transmitted.

The modifiers are listed below: -

Modifier	Operation
Bin {1..32}	Send binary digits
Dec {1..10}	Send decimal digits
Hex {1..8}	Send hexadecimal digits
Sbin {1..32}	Send signed binary digits
Sdec {1..10}	Send signed decimal digits
Shex {1..8}	Send signed hexadecimal digits
Ibin {1..32}	Send binary digits with a preceding '%' identifier
Idec {1..10}	Send decimal digits with a preceding '#' identifier
Ihex {1..8}	Send hexadecimal digits with a preceding '\$' identifier
ISbin {1..32}	Send signed binary digits with a preceding '%' identifier
ISdec {1..10}	Send signed decimal digits with a preceding '#' identifier
IShex {1..8}	Send signed hexadecimal digits with a preceding '\$' identifier
Rep c\n	Send character c repeated n times
Str array\n	Send all or part of an array
Cstr Label	Send string data defined in code memory.

The numbers after the **Bin**, **Dec**, and **Hex** modifiers are optional. If they are omitted, then the default is all the digits that make up the value will be displayed.

If a floating point variable is to be displayed, then the digits after the **Dec** modifier determine how many remainder digits are send. i.e. numbers after the decimal point.

```
Dim MyFloat as Float
MyFloat = 3.145
Hserout [Dec2 MyFloat]      ' Send 2 values after the decimal point
```

The above program will send 3.14

If the digit after the **Dec** modifier is omitted, then 3 values will be displayed after the decimal point.

```
Dim MyFloat as Float
MyFloat = 3.1456
Hserout [Dec MyFloat] ' Send 3 values after the decimal point
```

The above program will send 3.145

There is no need to use the **Sdec** modifier for signed floating point values, as the compiler's **Dec** modifier will automatically display a minus result: -

```
Dim MyFloat as Float
MyFloat = -3.1456
Hserout [Dec MyFloat] ' Send 3 values after the decimal point
```

The above program will transmit the ASCII representation of -3.145

Example

```
Device = 24FJ64GA002
Declare Xtal = 16
Declare Hserial_Baud = 9600 ' USART1 baud rate
Declare Hrsout1_Pin = PORTB.14 ' Select the pin for TX with USART1

Dim MyByte as Byte
Dim MyWord as Word
Dim MyDword as Dword

RPOR7 = 3 ' Make PPS Pin RP14 U1TX
Hserout ["Hello World"] ' Display the text "Hello World"
Hserout ["Var1= ", Dec MyByte] ' Display the decimal value of MyByte
Hserout ["Var1= ", Hex MyByte] ' Display the hexadecimal value of MyByte
Hserout ["Var1= ", Bin MyByte] ' Display the binary value of MyByte
' Display 6 hex characters of a Dword type variable
Hserout ["MyDword= ", Hex6 MyDword]
```

The **Cstr** modifier is used in conjunction with code memory strings. The **Dim as Code** directive is used for initially creating the string of characters: -

```
Dim String1 as Code = "Hello World", 0
```

The above line of code will create, in flash memory, the values that make up the ASCII text "Hello World", at address String1. Note the null terminator after the ASCII text.

Null terminated means that a zero (null) is placed at the end of the string of ASCII characters to signal that the string has finished.

To display, or transmit this string of characters, the following command structure could be used:

```
Hserout [Cstr String1]
```

The label that declared the address where the list of code memory values resided, now becomes the string's name. In a large program with lots of text formatting, this type of structure can save quite literally hundreds of bytes of valuable code space.

Try both these small programs, and you'll see that using **Cstr** saves a few bytes of code: -

First the standard way of displaying text: -

```
Device = 24FJ64GA002
Declare Xtal = 16
Declare Hserial_Baud = 9600      ' USART1 baud rate
Declare Hrsout1_Pin = PORTB.14   ' Select the pin for TX with USART1

RPOR7 = 3                        ' Make PPS Pin RP14 U1TX

Hserout ["Hello World\r"]
Hserout ["How are you?\r"]
Hserout ["I am fine!\r"]
```

Now using the **Cstr** modifier: -

```
Dim Text1 as Code = "Hello World", 0
Dim Text2 as Code = "How are you?\r", 0
Dim Text3 as Code = "I am fine!\r", 0

Hserout [Cstr Text1]
Hserout [Cstr Text2]
Hserout [Cstr Text3]
```

Again, note the null terminators after the ASCII text in the code memory strings. Without these, the device will continue to transmit data until a value 0 is reached.

The **Str** modifier is used for sending a string of bytes from a byte array variable. A string is a set of bytes sized values that are arranged or accessed in a certain order. The values 1, 2, 3 would be stored in a string with the value 1 first, followed by 2 then followed by the value 3. A byte array is a similar concept to a string; it contains data that is arranged in a certain order. Each of the elements in an array is the same size. The string 1,2,3 would be stored in a byte array containing three bytes (elements).

Below is an example that displays four bytes (from a byte array): -

```
Dim MyArray[10] as Byte      ' Create a 10-byte array.
MyArray [0] = "H"           ' Load the first 5 bytes of the array
MyArray [1] = "E"           ' With the data to send
MyArray [2] = "L"
MyArray [3] = "L"
MyArray [4] = "O"
Hserout [Str MyArray\5]     ' Display a 5-byte string.
```

Note that we use the optional \n argument of **Str**. If we didn't specify this, the microcontroller would try to keep sending characters until all 10 bytes of the array were transmitted. Since we do not wish all 10 bytes to be transmitted, we chose to tell it explicitly to only send the first 5 bytes.

The above example may also be written as: -

```
Dim MyArray [10] as Byte    ' Create a 10-byte array.
Str MyArray = "Hello"       ' Load the first 5 bytes of the array
Hserout [Str MyArray\5]     ' Send 5-byte string.
```

The above example, has exactly the same function as the previous one. The only difference is that the string is now constructed using **Str** as a command instead of a modifier.

Declares

There are several Declare directives for use with the **Hserout** commands. These are the same declares as used by the **HRsout** commands.

Notes.

Hserout can only be used with devices that contain a hardware USART. See the specific device's data sheet for further information concerning the serial input pin as well as other relevant parameters.

See also : **Declare, Rsin, Rsout, Serin, Serout, Hserin, Hserin.**

HseroutLn, Hserout2Ln, Hserout3Ln, Hserout4Ln

Syntax

```
HseroutLn [Item {, Item... }]  
Hserout2Ln [Item {, Item... }]  
Hserout3Ln [Item {, Item... }]  
Hserout4Ln [Item {, Item... }]
```

Overview

Transmit one or more *Items* from the hardware serial port on devices that contain one or more USART peripherals and terminate with a Carriage Return(13) or Carriage Return(13) Line Feed(10) or Line Feed(10) Carriage Return(13). The syntax and operators are exactly the same as **Hserout**, **Hserout2**, **Hserout3** and **Hserout4**. If **Hserout2Ln**, **Hserout3Ln**, or **HseroutLn** are used, the device must contain more than 1 USART.

Parameters

Item may be a constant, variable, expression, string list, modifier, or inline command. See the section on **Hserout** for more details.

Declares

There are 4 declares for the HseroutXLn commands. Each one is for the particular command.

```
Declare Hserial1_Terminator = CRLF or LFCR or CR  
Declare Hserial2_Terminator = CRLF or LFCR or CR  
Declare Hserial3_Terminator = CRLF or LFCR or CR  
Declare Hserial4_Terminator = CRLF or LFCR or CR
```

The parameter **CR** will transmit a single value of 13 at the end of transmission.

The parameter **CRLF** will transmit a value of 13 then 10 at the end of transmission.

The parameter **LFCR** will transmit a value of 10 then 13 at the end of transmission.

See also : **Declare**, **Rsin**, **Rsout**, **Serin**, **Serout**, **Hrsout**, **HrsoutLn**, **Hrsin**, **Hserin**, **Hserout**.

HSerial1_ChangeBaud

Syntax

HSerial1_ChangeBaud *Baud Value*, { *Display Actual Baud* }

Overview

Changes the Baud rate of USART1 for the **HRsout/HRsin** and **HSerout/HSerin** commands.

Parameters

Baud Value is a constant value that signifies which Baud rate to set USART1 at.

Display Actual Baud is an optional constant of 0 or 1 that will produce a reminder message in the IDE that indicates what the actual Baud rate is, and its error ratio.

Example

```
Device = 24FJ64GA306
Declare Xtal = 32
Declare HSerial_Baud = 9600           ' Set the Baud rate for USART1 to 9600
Declare HRSOut1_Pin PORTB.0         ' Set PORTB.0 as USART1 output pin

RPOR0 = 3                             ' Configure the PPS for USART1 on PORTB.0

HRsoutLn "Hello World at 9600 Baud"
DelayMs 2000                          ' Wait for 2 seconds

HSerial1_ChangeBaud 115200           ' Change the Baud rate to 115200
HRsoutLn "Hello World at 115200 Baud"
Stop
```

HSerial2_ChangeBaud

Syntax

HSerial2_ChangeBaud *Baud Value*, { *Display Actual Baud* }

Overview

Changes the Baud rate of USART2 for the **HRSout2/HRsin2** and **HSerout2/HSerin2** commands.

Parameters

Baud Value is a constant value that signifies which Baud rate to set USART2 at.

Display Actual Baud is an optional constant of 0 or 1 that will produce a reminder message in the IDE that indicates what the actual Baud rate is, and its error ratio.

Example

```
Device = 24FJ64GA306
Declare Xtal = 32
Declare HSerial2_Baud = 9600           ' Set the Baud rate for USART2 to 9600
Declare HRSOut2_Pin PORTB.0          ' Set PORTB.0 as USART2 output pin

RPOR0 = 5                             ' Configure the PPS for USART2 on PORTB.0

Hrsout2Ln "Hello World at 9600 Baud"
DelayMs 2000                          ' Wait for 2 seconds

HSerial2_ChangeBaud 115200           ' Change the Baud rate to 115200
Hrsout2Ln "Hello World at 115200 Baud"
Stop
```

HSerial3_ChangeBaud

Syntax

HSerial3_ChangeBaud *Baud Value*, { *Display Actual Baud* }

Overview

Changes the Baud rate of USART3 for the **HRsout3/HRsin3** and **HSerout3/HSerin3** commands.

Parameters

Baud Value is a constant value that signifies which Baud rate to set USART3 at.

Display Actual Baud is an optional constant of 0 or 1 that will produce a reminder message in the IDE that indicates what the actual Baud rate is, and its error ratio.

Example

```
Device = 24FJ64GA306           ' Use a device that has 4 USARTs
Declare Xtal = 32
Declare HSerial3_Baud = 9600   ' Set the Baud rate for USART3 to 9600
Declare HRSOut3_Pin PORTB.0    ' Set PORTB.0 as USART3 output pin

RPOR0 = 28                     ' Configure the PPS for USART3 on PORTB.0

HRsout3Ln "Hello World at 9600 Baud"
DelayMs 2000                   ' Wait for 2 seconds

HSerial3_ChangeBaud 115200     ' Change the Baud rate to 115200
HRsoutLn "Hello World at 115200 Baud"
Stop
```

HSerial4_ChangeBaud

Syntax

HSerial4_ChangeBaud *Baud Value*, { *Display Actual Baud* }

Overview

Changes the Baud rate of USART4 for the **HRsout4/HRsin4** and **HSerout4/HSerin4** commands.

Parameters

Baud Value is a constant value that signifies which Baud rate to set USART4 at.

Display Actual Baud is an optional constant of 0 or 1 that will produce a reminder message in the IDE that indicates what the actual Baud rate is, and its error ratio.

Example

```
Device = 24FJ64GA306           ' Use a device that has 4 USARTs
Declare Xtal = 32
Declare HSerial4_Baud = 9600    ' Set the Baud rate for USART4 to 9600
Declare HRSOut4_Pin PORTB.0    ' Set PORTB.0 as USART4 output pin

RPOR0 = 30                     ' Configure the PPS for USART1 on PORTB.0

HRsout4Ln "Hello World at 9600 Baud"
DelayMs 2000                   ' Wait for 2 seconds

HSerial4_ChangeBaud 115200      ' Change the Baud rate to 115200
Hrsout4Ln "Hello World at 115200 Baud"
Stop
```

I2Cin

Syntax

I2Cin *Dpin*, *Cpin*, *Control*, { *Address* }, [*Variable* {, *Variable*...}]

Overview

Receives a value from the I²C bus, and places it into *Variable*/s.

Parameters

Dpin is a Port.Pin constant that specifies the I/O pin that will be connected to the I²C device's data line (SDA). This pin's I/O direction will be changed to input and will remain in that state after the instruction is completed.

Cpin is a Port.Pin constant that specifies the I/O pin that will be connected to the I²C device's clock line (SCL). This pin's I/O direction will be changed to input and will remain in that state after the instruction is completed.

Variable is a user defined variable of type **Bit**, **Byte**, **Word**, **Dword**, **Float**, **Array**.

Control is a constant value or a byte sized variable expression.

Address is an optional constant value or a variable expression.

The **I2Cin** command operates as an I²C master, and may be used to interface with any device that complies with the 2-wire I²C protocol. The most significant 7-bits of control byte contain the control code and the slave address of the device being interfaced with. Bit-0 is the flag that indicates whether a read or write command is being implemented.

For example, if we were interfacing to an external eeprom such as the 24LC32, the control code would be %10100001 or \$A1. The most significant 4-bits (1010) are the eeprom's unique slave address. Bits 1 to 3 reflect the three address pins of the eeprom. And bit-0 is set to signify that we wish to read from the eeprom. Note that this bit is automatically set by the **I2Cin** command, regardless of its initial setting.

Example

```
' Receive a byte from the I2C bus and place it into variable Var1.
Device = 24FJ64GA002
Declare Xtal = 16

Dim MyByte as Byte           ' We'll only read 8-bits
Dim Address as Word          ' 16-bit address required
Symbol Control %10100001    ' Target an eeprom
Symbol SDA = PORTC.3        ' Alias the SDA (Data) line
Symbol SCL = PORTC.4        ' Alias the SSL (Clock) line

Address = 20                 ' Read the value at address 20
I2Cin SDA, SCL, Control, Address, [MyByte] ' Read the byte from the eeprom
```

Address is an optional parameter that may be an 8-bit or 16-bit value. If a variable is used in this position, the size of address is dictated by the size of the variable used (byte or word). In the case of the previous eeprom interfacing, the 24LC32 eeprom requires a 16-bit address. While the smaller types require an 8-bit address. Make sure you assign the right size address for the device interfaced with, or you may not achieve the results you intended.

The **I2Cin** command allows differing variable assignments. For example: -

```
Dim Var1 as Byte
Dim MyWord as Word
I2Cin SDA, SCL, Control, Address, [Var1, MyWord]
```

The above example will receive two values from the bus, the first being an 8-bit value dictated by the size of variable Var1 which has been declared as a byte. And a 16-bit value, this time dictated by the size of the variable MyWord which has been declared as a word. Of course, bit type variables may also be used, but in most cases these are not of any practical use as they still take up a byte within the eeprom.

Declares

See **I2Cout** for declare explanations.

Notes.

When the **I2Cin** command is used, the appropriate SDA and SCL Port and Pin are automatically setup as inputs, and outputs. Because the I²C protocol calls for an open-collector interface, pull-up resistors are required on both the SDA and SCL lines. Values of 4.7KΩ to 10KΩ will suffice.

Str modifier with I2Cin

Using the **Str** modifier allows the **I2Cin** command to transfer the bytes received from the I²C bus directly into a byte array. If the amount of received characters is not enough to fill the entire array, then a formatter may be placed after the array's name, which will only receive characters until the specified length is reached. An example of each is shown below: -

```
Device = 24FJ64GA002
Declare Xtal = 16

Dim Array[10] as Byte           ' Create an array of 10 bytes
Dim Address as Byte           ' Create a word sized variable
,
' Load data into all the array
,
I2Cin SDA, SCL, %10100000, Address, [Str Array]
,
' Load data into only the first 5 elements of the array
,
I2Cin SDA, SCL, %10100000, Address, [Str Array\5]
```

See Also: **BusAck, Bstart, Brestart, Bstop, Busout, HbStart, HbRestart, HbusAck, Hbusin, Hbusout, I2Cout**

I2Cout

Syntax

I2Cout *Control*, { *Address* }, [*OutputData*]

Overview

Transmit a value to the I²C bus, by first sending the *control* and optional *address*.

Parameters

Dpin is a Port.Pin constant that specifies the I/O pin that will be connected to the I²C device's data line (SDA). This pin's I/O direction will be changed to input and will remain in that state after the instruction is completed.

Cpin is a Port.Pin constant that specifies the I/O pin that will be connected to the I²C device's clock line (SCL). This pin's I/O direction will be changed to output.

Control is a constant value or a byte sized variable expression.

Address is an optional constant, variable, or expression.

OutputData is a list of variables, constants, expressions and modifiers that informs I2Cout how to format outgoing data. **I2Cout** can transmit individual or repeating bytes, convert values into decimal, hex or binary text representations, or transmit strings of bytes from variable arrays.

These actions can be combined in any order in the OutputData list.

The **I2Cout** command operates as an I²C master and may be used to interface with any device that complies with the 2-wire I²C protocol. The most significant 7-bits of *control* byte contain the control code and the slave address of the device being interfaced with. Bit-0 is the flag that indicates whether a read or write command is being implemented.

For example, if we were interfacing to an external eeprom such as the 24LC32, the control code would be %10100000 or \$A0. The most significant 4-bits (1010) are the eeprom's unique slave address. Bits 1 to 3 reflect the three address pins of the eeprom. And Bit-0 is clear to signify that we wish to write to the eeprom. Note that this bit is automatically cleared by the **I2Cout** command, regardless of its initial value.

Example

```
' Send a byte to the I2C bus.
Device = 24FJ64GA002
Declare xtal = 16

Dim MyByte as Byte           ' We'll only read 8-bits
Dim Address as Word          ' 16-bit address required
Symbol Control = %10100000  ' Target an eeprom
Symbol SDA = PORTC.3        ' Alias the SDA (Data) line
Symbol SCL = PORTC.4        ' Alias the SCL (Clock) line

Address = 20                 ' Write to address 20
MyByte = 200                 ' The value place into address 20
I2Cout SDA, SCL, Control, Address, [MyByte] ' Send the byte to the eeprom
DelayMs 10                   ' Allow time for allocation of byte
```

Address is an optional parameter that may be an 8-bit or 16-bit value. If a variable is used in this position, the size of *address* is dictated by the size of the variable used (byte or word). In the case of the above eeprom interfacing, the 24LC32 eeprom requires a 16-bit address. While the smaller types require an 8-bit address. Make sure you assign the right size address for the device interfaced with, or you may not achieve the results you intended.

The value sent to the bus depends on the size of the variables used. For example: -

```
Dim MyWord as Word           ' Create a Word size variable
I2Cout SDA, SCL, Control, Address, [MyWord]
```

Will send a 16-bit value to the bus. While: -

```
Dim MyByte as Byte          ' Create a Byte size variable
I2Cout SDA, SCL, Control, Address, [MyByte]
```

Will send an 8-bit value to the bus. Using more than one variable within the brackets allows differing variable sizes to be sent. For example: -

```
Dim MyByte as Byte
Dim MyWord as Word
I2Cout SDA, SCL, Control, Address, [MyByte, MyWord]
```

Will send two values to the bus, the first being an 8-bit value dictated by the size of variable MyByte which has been declared as a byte. And a 16-bit value, this time dictated by the size of the variable MyWord which has been declared as a word. Of course, bit type variables may also be used, but in most cases these are not of any practical use as they still take up a byte within the eeprom.

A string of characters can also be transmitted, by enclosing them in quotes: -

```
I2Cout SDA, SCL, Control, Address, ["Hello World", MyByte, MyWord]
```

Str modifier with I2Cout

The **Str** modifier is used for transmitting a string of bytes from a byte array variable. A string is a set of bytes sized values that are arranged or accessed in a certain order. The values 1, 2, 3 would be stored in a string with the value 1 first, followed by 2 then followed by the value 3. A byte array is a similar concept to a string; it contains data that is arranged in a certain order. Each of the elements in an array is the same size. The string 1,2,3 would be stored in a byte array containing three bytes (elements). Below is an example that sends four bytes from an array: -

```
Device = 24FJ64GA002
Declare Xtal = 16

Dim MyArray[10] as Byte      ' Create a 10-byte array.
MyArray [0] = "A"           ' Load the first 4 bytes of the array
MyArray [1] = "B"           ' With the data to send
MyArray [2] = "C"
MyArray [3] = "D"
' Send a 4-byte string
I2Cout SDA, SCL, %10100000, Address, [Str MyArray\4]
```

Note that we use the optional \n argument of **Str**. If we didn't specify this, the program would try to keep sending characters until all 10 bytes of the array were transmitted. Since we do not wish all 10 bytes to be transmitted, we chose to tell it explicitly to only send the first 4 bytes.

Declares

There are two **Declare** directives for use with **I2Cout**. These are: -

Declare I2C_Slow_Bus On - Off or 1 – 0

Slows the bus speed when using an oscillator higher than 4MHz. The standard speed for the I²C bus is 100KHz. Some devices use a higher bus speed of 400KHz. If you use an 8MHz or higher oscillator, the bus speed may exceed the devices specs, which will result in intermittent transactions, or in some cases, no transactions at all. Therefore, use this **Declare** if you are not sure of the device's spec. The datasheet for the device used will inform you of its bus speed.

Declare I2C_Bus_SCL On - Off, 1 - 0

Eliminates the necessity for a pull-up resistor on the SCL line.

The I²C protocol dictates that a pull-up resistor is required on both the SCL and SDA lines, however, this is not always possible due to circuit restrictions etc, so once the **I2C_Bus_SCL On Declare** is issued at the top of the program, the resistor on the SCL line can be omitted from the circuit. The default for the compiler if the **I2C_Bus_SCL Declare** is not issued, is that a pull-up resistor is required.

Notes.

When the **I2Cout** command is used, the appropriate SDA and SCL Port and Pin are automatically setup as inputs, and outputs. Because the I²C protocol calls for an *open-collector* interface, pull-up resistors are required on both the SDA and SCL lines. Values of 4.7K Ω to 10K Ω will suffice.

You may imagine that it's limiting having a fixed set of pins for the I²C interface, but you must remember that several different devices may be attached to a single bus, each having a unique slave address. Which means there is usually no need to use up more than two pins on the microcontroller in order to interface to many devices.

See Also: **BusAck, Bstart, Brestart, Bstop, Busin, HbStart, HbRestart, HbusAck, Hbusin, Hbusout, I2Cin**

If..Then..Elseif..Else..EndIf

Syntax

If *Comparison* **Then** *Instruction* : { *Instruction* }

Or, you can use the single line form syntax:

If *Comparison* **Then** *Instruction* : { *Instruction* } : **Elseif** *Comparison* **Then** *Instruction* : **Else** *Instruction*

Or, you can use the block form syntax:

```
If Comparison Then  
Instruction(s)  
Elseif Comparison Then  
Instruction(s)  
{  
Elseif Comparison Then  
Instruction(s)  
}  
Else  
Instruction(s)  
EndIf
```

The curly braces signify optional conditions.

Overview

Evaluates the *comparison* and, if it fulfils the criteria, executes *expression*. If *comparison* is not fulfilled the *instruction* is ignored, unless an **Else** directive is used, in which case the code after it is implemented until the **EndIf** is found.

When all the instruction are on the same line as the **If-Then** statement, all the instructions on the line are carried out if the condition is fulfilled.

Parameters

Comparison is composed of variables, numbers and comparators.

Instruction is the statement to be executed should the *comparison* fulfil the **If** criteria

Example 1

```
Device = 24FJ64GA002  
Declare Xtal = 16  
Symbol LED = PORTB.4  
  
MyByte = 3  
Low LED  
If MyByte > 4 Then High LED : DelayMs 500 : Low LED
```

In the above example, MyByte is not greater than 4 so the **If** criteria isn't fulfilled. Consequently, the **High** LED statement is never executed leaving the state of port pin PORTB.4 low. However, if we change the value of variable Var1 to 5, then the LED will turn on for 500ms then off, because MyByte is now greater than 4, so fulfills the *comparison* criteria.

A second form of **If**, evaluates the expression and if it is true then the first block of instructions is executed. If it is false then the second block (after the **Else**) is executed.

The program continues after the **EndIf** instruction.

The **Else** is optional. If it is missed out then if the expression is false the program continues after the **EndIf** line.

Example 2

```
If MyVar1 & 1 = 0 Then
    MyVar2 = 0
    MyVar3 = 1
Else
    MyVar2 = 1
EndIf
If MyVar4 = 1 Then
    MyVar2 = 0
    MyVar3 = 0
EndIf
```

Example 3

```
If MyVar1 = 10 Then
    High LED1
ElseIf MyVar1 = 20 Then
    High LED2
Else
    High LED3
EndIf
```

A forth form of **If**, allows the **Else** or **Elseif** to be placed on the same line as the **If**: -

```
If MyVar1 = 10 Then High LED1 : ElseIf MyVar1 = 20 Then High LED2 : Else : High LED3
```

Notice that there is no **EndIf** instruction. The comparison is automatically terminated by the end of line condition. So in the above example, if MyVar1 is equal to 10 then LED1 will illuminate, if MyVar1 equals 20 then LED will illuminate, otherwise, LED3 will illuminate.

The **If** statement allows any type of variable, register or constant to be compared. A common use for this is checking a Port bit: -

```
If PORTA.0 = 1 Then High LED : Else : Low LED
```

Any commands on the same line after **Then** will only be executed if the comparison is fulfilled: -

```
If MyVar1 = 1 Then High LED : DelayMs 500 : Low LED
```

Notes.

A **GoTo** command is optional after the **Then**: -

```
If PORTB.0 = 1 Then Label
```

Then always required.

The Proton24 compiler relies heavily on the **Then** part. Therefore, if the **Then** part of a construct is left out of the code listing, a Syntax Error will be produced.

See also : **Boolean Logic Operators, Select..Case..EndSelect.**

Include

Syntax

Include "Filename"

Overview

Include another file at the current point in the compilation. All the lines in the new file are compiled as if they were in the current file at the point of the **Include** directive.

A common use for the include command is shown in the example below. Here a small master program is used to include a number of smaller library files which are all compiled together to make the overall program.

Parameter

Filename is any valid Proton24 file.

Example

```
' Main Program Includes sub files
  Include "StartCode.inc"
  Include "MainCode.inc"
  Include "EndCode.inc"
```

Notes.

The file to be included into the BASIC listing may be in one of several places on the hard drive if a specific path is not chosen.

- 1... Within the BASIC program's directory.
- 2... Within the Compiler's current directory.
- 3... Within the user's Includes folder, located in the user's PDS directory.
- 4... Within the Includes folder of the compiler's current directory.
- 5... Within the Includes\Sources folder of the compiler's current directory.

The list above also shows the order in which they are searched for.

Using Include files to tidy up your code.

There are some considerations that must be taken into account when writing code for an include file, these are: -

- 1). Always jump over the subroutines.

When the include file is placed at the top of the program this is the first place that the compiler starts, therefore, it will run the subroutine/s first and the **Return** command will be pointing to a random place within the code. To overcome this, place a **GoTo** statement just before the subroutine starts.

For example: -

```
GoTo Over_This_Subroutine ' Jump over the subroutine  
' The subroutine is placed here
```

```
Over_This_Subroutine:      ' Jump to here first
```

2). Variable and Label names should be as meaningful as possible.

For example. Instead of naming a variable **Loop**, change it to **Isub_Loop**. This will help eliminate any possible duplication errors, caused by the main program trying to use the same variable or label name. However, try not to make them too obscure as your code will be harder to read and understand, it might make sense at the time of writing, but come back to it after a few weeks and it will be meaningless.

3). Comment, Comment, and Comment some more.

This cannot be emphasised enough. Always place a plethora of remarks and comments. The purpose of the subroutine/s within the include file should be clearly explained at the top of the program, also, add comments after virtually every command line, and clearly explain the purpose of all variables and constants used. This will allow the subroutine to be used many weeks or months after its conception. A rule of thumb that I use is that I can understand what is going on within the code by reading only the comments to the right of the command lines.

Inc

Syntax

Inc Variable

Overview

Increment a variable i.e. $Var1 = Var1 + 1$

Parameters

Variable is a user defined variable

Example

```
Device = 24FJ64GA002
Declare Xtal = 16
Declare Hserial_Baud = 9600      ' USART1 baud rate
Declare Hrsout1_Pin = PORTB.14  ' Select the pin for TX with USART1

Dim MyDword as Dword

RPOR7 = 3                        ' Make PPS Pin RP14 U1TX
MyDword = 1
Repeat
    Hrsout Dec MyDword, 13
    DelayMs 200
    Inc MyDword
Until MyDword > 10000
```

The above example shows the equivalent to the For-Next loop: -

```
For MyDword = 1 to 10000 : Next
```

However, the **Repeat-Until** version, although it looks more complex, is much more efficient in both code size and speed of operation.

See also : Dec.

Inkey

Syntax

Assignment Variable = Inkey

Overview

Scan a keypad and place the returned value into *variable*

Parameters

Assignment Variable is a user defined variable

Example

```

Device = 24FJ64GA002
Declare Xtal = 16
Declare Hserial_Baud = 9600      ' USART1 baud rate
Declare Hrsout1_Pin = PORTB.14  ' Select the pin for TX with USART1
Declare Keypad_Port = PORTB

Dim MyByte as Byte
RPOR7 = 3                        ' Make PPS Pin RP14 U1TX

Do                               ' Create an infinite loop
  MyByte = Inkey                 ' Scan the keypad
  DelayMs 50                    ' Simple debounce by waiting 50ms
  Hrsout Dec MyByte, 13         ' Display the result
Loop                             ' Do it forever
    
```

Notes.

Inkey will return a value between 0 and 16. If no key is pressed, the value returned is 16.

Using a **LookUp** command, the returned values can be re-arranged to correspond with the legends printed on the keypad: -

```

MyByte = Inkey
MyKey = LookUp MyByte, [255,1,4,7,"*",2,5,8,0,3,6,9,"#",0,0,0]
    
```

The above example is only a demonstration, the values inside the **LookUp** command will need to be re-arranged for the type of keypad used, and its connection configuration.

Declare

Declare Keypad_Port Port

Assigns the 8-bits of a Port that the keypad is attached to.

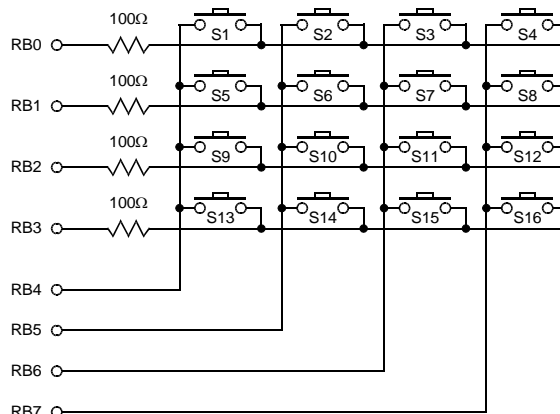

The diagram above illustrates typical connections for a 16-button keypad.

Input

Syntax

Input *Port* . *Pin* or *Pin Number*

Overview

Makes the specified *Port* or *Pin* an input.

Parameters

Port.Pin must be a Port, or Port.Pin constant declaration.

Pin Number can be any variable or constant holding 0 to the amount of I/O pins on the device. A value of 0 will be **PORTA.0**, if present, 1 will be **PORTA.1**, 16 will be **PORTB.0** etc...

Example 1

```
Input PORTB.0      ' Make bit-0 of PORTB an input
Input PORTB        ' Make all of PORTB an input
Input 0            ' Make pin-0 of PORTA an input
Input 16           ' Make pin-0 of PORTB an input
```

Example 2

```
' Flash each of the pins on PORTB
'
Device = 24FJ64GA002
Declare Xtal = 16

Dim PinNumber as Byte

High PORTB
For PinNumber = 16 to 31      ' Create a loop for the pin to flash
    Output PinNumber         ' Set the pin as an output
    DelayMs 500              ' Delay so that it can be seen
    Input PinNumber          ' Set the pin as an input
    DelayMs 500              ' Delay so that it can be seen
Next
```

Notes.

An Alternative method for making a particular pin an input is by directly modifying the TRIS register: -

```
TRISB.0 = 1      ' Make bit-0 of PORTB an input
```

All of the pins on a port may be set to inputs by setting the whole TRIS register at once: -

```
TRISB = %1111111111111111 ' Set all of PORTB to inputs
```

In the above examples, setting a TRIS bit to 1 makes the pin an input, and conversely, setting the bit to 0 makes the pin an output.

Each pin number has a designated name. These are Pin_A0, Pin_A1, Pin_A2, Pin_B0...Pin_B15, Pin_C0...Pin_C15, Pin_D0...Pin_D15 to Pin_L15 etc... Each of the names has a relevant value, for example, Pin_A0 has the value 0, Pin_B0 has the value 16, up to Pin_J15, which has the value 143.

These can be used to pass a relevant pin number to a Procedure. For example:

```
,  
' Flash an LED attached to PORTB.0 via a procedure  
' Then flash an LED attached to PORTB.1 via the same procedure  
,  
Device = 24HJ128GP502  
Declare Xtal = 16  
  
Do                               ' Create a loop  
    FlashPin(Pin_B0)             ' Call the procedure to flash PORTB.0  
    FlashPin(Pin_B1)             ' Call the procedure to flash PORTB.1  
Loop                               ' Do it forever  
,  
' Set a pin high then an input for 500ms using a value as the pin to adjust  
,  
Proc FlashPin(pPinNumber As Byte)  
    High pPinNumber              ' Set the pin output high  
    DelayMs 500                  ' Wait for 500 milliseconds  
    Input pPinNumber             ' Make the pin an input  
    DelayMs 500                  ' Wait for 500 milliseconds  
EndProc
```

See also : ClearPin, Output, SetPin, Low, High.

Isr, EndIsr

Syntax

```
Isr Interrupt Name, {UnHandled}
Interrupt handler BASIC code goes here
EndIsr
```

Overview

Indicate the start and end of an interrupt handling subroutine.

Parameters

Interrupt Name is the name of the interrupt being handled by the subroutine.

Unhandled is an optional parameter that will disable context saving and restoring of the **WREG** SFRs and key SFRs, as well as compiler system variables. Use this option with caution and only when you know that the interrupt handler's code will not disturb any other SFRs or variables.

Unlike 8-bit PIC[®] microcontroller's, PIC24[®] and dsPIC33[®] devices have a separate vector for each type of interrupt. Each interrupt has a specific name, and there are up to 128 of them. A typical interrupt vector name list is shown below:

Interrupt Name	Interrupt Cause
OscillatorFail	Oscillator Failure (Non-Maskable)
StackError	Address Error (Non-Maskable)
AddressError	Stack Error (Non-Maskable)
MathError	Math Error (Non-Maskable)
DMACError	DMA Error (Non-Maskable)
INT0Interrupt	External Interrupt 0
IC1Interrupt	Input Capture 1
OC1Interrupt	Output Compare 1
T1Interrupt	Timer1
DMA0Interrupt	DMA Channel 0
IC2Interrupt	Input Capture 2
OC2Interrupt	Output Compare 2
T2Interrupt	Timer2
T3Interrupt	Timer3
SPI1ErrInterrupt	SPI1 Error
SPI1Interrupt	SPI1 Transfer Done
U1RXInterrupt	UART1 Receiver
U1TXInterrupt	UART1 Transmitter
ADC1Interrupt	ADC 1
DMA1Interrupt	DMA Channel 1
SI2C1Interrupt	I ² C1 Slave Events
MI2C1Interrupt	I ² C1 Master Events
CNInterrupt	Change Notification Interrupt
INT1Interrupt	External Interrupt 1
IC7Interrupt	Input Capture 7
IC8Interrupt	Input Capture 8
DMA2Interrupt	DMA Channel 2
OC3Interrupt	Output Compare 3
OC4Interrupt	Output Compare 4

Interrupt Name	Interrupt Cause
T4Interrupt	Timer4
T5Interrupt	Timer5
INT2Interrupt	External Interrupt 2
U2RXInterrupt	UART2 Receiver
U2TXInterrupt	UART2 Transmitter
SPI2ErrInterrupt	SPI2 Error
SPI2Interrupt	SPI1 Transfer Done
DMA3Interrupt	DMA Channel 3
IC3Interrupt	Input Capture 3
IC4Interrupt	Input Capture 4
IC5Interrupt	Input Capture 5
IC6Interrupt	Input Capture 6
OC5Interrupt	Output Compare 5
OC6Interrupt	Output Compare 6
OC7Interrupt	Output Compare 7
OC8Interrupt	Output Compare 8
DMA4Interrupt	DMA Channel 4
T6Interrupt	Timer6
T7Interrupt	Timer7
SI2C2Interrupt	I ² C2 Slave Events
MI2C2Interrupt	I ² C2 Master Events
T8Interrupt	Timer8
T9Interrupt	Timer9
INT3Interrupt	External Interrupt 3
INT4Interrupt	External Interrupt 4
U1ErrInterrupt	UART1 Error
U2ErrInterrupt	UART2 Error

There are commonalities for the names on all PIC24[®] and dsPIC33[®] devices, however, interrupt vector names will be added if the device has a specific peripheral. A full list of the interrupt names for a specific device can be found within the device's **PPI** file, under the [ISRSTART] section. The PPI files can be found within the compiler's "PDS\Includes\PPI" directory.

The first 5 names in the list are interrupts that cannot be disabled. i.e. Non-Maskable, and are used for exception handling within the microcontroller. The others in the list are Maskable, meaning they can be enabled or disabled accordingly.

The interrupt handler, unless otherwise indicated, will first disable any other interrupts, then save key SFRs (Special Function Registers) such as **SR** (**STATUS** on 8-bit devices), **CORCON**, **RCOUNT**, **WREG0** to **WREG14**, then if available on the device being used, **PSVPAG**, **DSRPAG**, **DCOUNT**, **DOSTART**, and **DOEND**. If the device has more than 65K or code memory, the **TBLPAG** SFR will also be saved. Saving is accomplished by pushing the SFRs or variables onto the microcontroller's stack, which will expand to accommodate them.

It will then save any compiler system variables that are used within the interrupt handler, before re-enabling interrupts and handing control to the code within the interrupt handler. The reverse is accomplished when the interrupt is exited, and the **Retfie** mnemonic issued. Note that the interrupt handler will not reset any associated interrupt flag.

This means that pretty much any BASIC code can be placed inside an interrupt as long as it handles any peripheral conflicts, such as Port re-use etc...

If additional SFRs or variables need to be saved within the interrupt handler, they can be pushed onto the stack then popped from it before the interrupt exits. For example:

```
Isr T1Interrupt
  Push TRISB           ' Save 16-bit TRISB on the stack
  Push PORTB          ' Save 16-bit PORTB on the stack
  Toggle PORTB        ' Use TRISB and PORTB
  Pop PORTB           ' Restore 16-bit PORTB from the stack
  Pop TRISB           ' Restore 16-bit TRISB from the stack
  IFS0bits_T1IF = 0   ' Reset the Timer1 interrupt flag
EndIsr                ' Exit the interrupt
```

Note that the compiler can only track its system variable use when the code is between **Isr** and **EndIsr**. It cannot track any code that is called as a subroutine or a procedure from the ISR handler.

An asm **Bra** mnemonic is placed before the **Isr** directive, that jumps over the handler code past the **EndIsr** directive. This means that the interrupt handler can be placed in the line of code without having to jump over it manually. However, this behaviour can be altered by adding a dash after the **Isr** and **EndIsr** directives: **Isr-** and **EndIsr-**. This will save two bytes of code space for every interrupt handler used in the BASIC program, but measures should be taken to make sure that the program does not run the interrupt code directly, such as a **GoTo** to the main program loop.

Example

```
'
' Timer interrupt demo
'
Device = 24FJ64GA002
Declare Xtal = 16
Declare Hserial_Baud = 9600           ' UART1 baud rate
Declare Hrsout1_Pin = PORTB.14       ' Select which pin for TX with USART1

Dim FloatOut1 As Float
Dim FloatOut2 As Float

'-----
GoTo Main                            ' Jump over the interrupt handlers
'-----
' Timer1 interrupt handler
' Transmit a floating point value serially
'
Isr- T1Interrupt                      ' Context save
  HRSOut "Timer1 ", Dec1 FloatOut1, 13
  FloatOut1 = FloatOut1 + 0.1
  IFS0bits_T1IF = 0                  ' Reset the Timer1 interrupt flag
EndIsr-                               ' Context restore and exit the interrupt
'-----
' Timer2 interrupt handler
' Transmit a floating point value serially
'
Isr - T2Interrupt                    ' Context save
  HRSOut "Timer2 ", Dec1 FloatOut2, 13
  FloatOut2 = FloatOut2 + 0.1
  IFS0bits_T2IF = 0                  ' Reset the Timer2 interrupt flag
EndIsr-                               ' Context restore and exit the interrupt
```

```
-----  
Main:  
    RPOR7 = 3           ' Make PPS Pin RP14 UITX  
    FloatOut1 = 0  
    FloatOut2 = 0  
,  
' Configure Timer1  
,  
    TMR1 = 0  
    PR1 = 8192         ' Load Timer1 period  
    T1CON = %101000000101001 ' Start Timer1  
                                ' Discontinue operation in Idle mode  
                                ' Gated time accumulation disabled  
                                ' 1:64 prescaler  
                                ' Do not synchronise external clock input  
                                ' Internal clock  
  
    IFS0bits_T1IF = 0   ' Clear Timer1 interrupt flag  
    IPC0bits_T1IP0 = 0 ' Set priority  
    IEC0bits_T1IE = 1   ' Enable the Timer1 interrupt  
,  
' Configure Timer2  
,  
    TMR2 = 0  
    PR2 = 8192         ' Load Timer2 period  
    T2CON = %1010000000110101 ' Start Timer2  
                                ' Discontinue operation in Idle mode  
                                ' Gated time accumulation disabled  
                                ' 1:256 prescaler  
                                ' Timer2 as 16-bit timer  
                                ' Internal clock  
  
    IFS0bits_T2IF = 0   ' Clear Timer2 interrupt flag  
    IPC1bits_T2IP0 = 0 ' Set priority  
    IEC0bits_T2IE = 1   ' Enable the Timer2 interrupt
```

The program above shows a worse case scenario of each interrupt calculating and displaying floating point variables, which are among the most processor intensive operations.

Adding another interrupt is as simple as placing **Isr** and **EndIsr** directives with a given name, and configuring the microcontroller to initiate the interrupt. The compiler will take care of the rest as much as it can.

Notes.

Nesting of **Isr** and **EndIsr** directives is not allowed.

The naming of the interrupts is taken from the official Microchip™ documentation and are the names used by the Linker application.

LCDread

Syntax

Assignment Variable = **LCDread** *Ypos*, *Xpos*

Overview

Read a byte from a graphic LCD.

Parameters

Assignment Variable is a user defined variable.

Ypos :-

With a KS0108 graphic LCD this may be a constant, variable or expression within the range of 0 to 7 This corresponds to the line number of the LCD, with 0 being the top row.

With a Toshiba T6963 graphic LCD this may be a constant, variable or expression within the range of 0 to the Y resolution of the display. With 0 being the top line.

Xpos :-

With a KS0108 graphic LCD this may be a constant, variable or expression with a value of 0 to 127. This corresponds to the X position of the LCD, with 0 being the far left column.

With a Toshiba graphic LCD this may be a constant, variable or expression with a value of 0 to the X resolution of the display divided by the font width ($LCD_X_Res / LCD_Font_Width$). This corresponds to the X position of the LCD, with 0 being the far left column.

Example

```
' Read and display the top row of the KS0108 graphic LCD
Device = 24HJ128GP502
Declare Xtal = 16
,
' LCD interface pin assignments
,
Declare LCD_Type = KS0108           ' Setup for a KS0108 graphic LCD
Declare LCD_DTPort = PORTB.Byte0
Declare LCD_CS1Pin = PORTB.8
Declare LCD_CS2Pin = PORTB.9
Declare LCD_ENPin = PORTB.10
Declare LCD_RSPin = PORTB.11
Declare LCD_RWPin = PORTB.12

Dim Var1 as Byte
Dim Xpos as Byte
Cls                                 ' Clear the LCD
Print "Testing 1 2 3"
For Xpos = 0 to 127                 ' Create a loop of 128
    Var1 = LCDread 0, Xpos          ' Read the LCD's top line
    Print At 1, 0, "Chr= ", Dec Var1, " "
    DelayMs 100
Next
```

Notes.

The graphic LCDs that are compatible with Proton24 are the KS0108, and the Toshiba T6963. The KS0108 display usually has a pixel resolution of 64 x 128. The 64 being the Y axis, made up of 8 lines each having 8-bits. The 128 being the X axis, made up of 128 positions. The Toshiba LCDs are available with differing resolutions.

As with **LCDwrite**, the graphic LCD must be targeted using the **LCD_Type Declare** directive before this command may be used.

See also : **LCDwrite** for a description of the screen formats, **Pixel**, **Plot**, **Toshiba_Command**, **Toshiba_UDG**, **UnPlot**, see **Print** for LCD connections.

LCDwrite

Syntax

LCDwrite *Ypos*, *Xpos*, [*Value*, { *Value etc...* }]

Overview

Write a byte to a graphic LCD.

Parameters

Ypos :-

With a KS0108 graphic LCD this may be a constant, variable or expression within the range of 0 to 7 This corresponds to the line number of the LCD, with 0 being the top row.

With a **Toshiba** T6963 graphic LCD this may be a constant, variable or expression within the range of 0 to the Y resolution of the display. With 0 being the top line.

Xpos :-

With a KS0108 graphic LCD this may be a constant, variable or expression with a value of 0 to 127. This corresponds to the X position of the LCD, with 0 being the far left column.

With a **Toshiba** graphic LCD this may be a constant, variable or expression with a value of 0 to the X resolution of the display divided by the font width ($LCD_X_Res / LCD_Font_Width$). This corresponds to the X position of the LCD, with 0 being the far left column.

Value may be a constant, variable, or expression, within the range of 0 to 255 (byte).

Example 1

```
' Display a line on the top row of a KS0108 graphic LCD
Device = 24HJ128GP502
Declare Xtal = 16
'
' LCD interface pin assignments
'
Declare LCD_Type = KS0108           ' Setup for a KS0108 graphic LCD
Declare LCD_DTPort = PORTB.Byte0
Declare LCD_CS1Pin = PORTB.8
Declare LCD_CS2Pin = PORTB.9
Declare LCD_ENPin = PORTB.10
Declare LCD_RSPin = PORTB.11
Declare LCD_RWPin = PORTB.12

Dim Xpos as Byte
Cls                                 ' Clear the LCD
For Xpos = 0 to 127                 ' Create a loop of 128
    LCDwrite 0, Xpos, [%11111111]  ' Write to the LCD's top line
    DelayMs 100
Next
```

Example 2

```

' Display a line on the top row of a Toshiba 128x64 graphic LCD
Device = 24HJ128GP502
Declare xtal = 16

Include "T6963C.Inc"           ' Load the T6983 routines into the program

Dim Xpos as Byte
Cls                             ' Clear the LCD
For Xpos = 0 to 20              ' Create a loop of 21
    LCDwrite 0, Xpos, [%00111111] ' Write to the LCD's top line
    DelayMs 100
Next
    
```

Notes.

The graphic LCDs that are compatible with Proton24 are the KS0108, and the Toshiba T6963 (which must be included separately). The KS0108 display has a pixel resolution of 64 x 128. The 64 being the Y axis, made up of 8 lines each having 8-bits. The 128 being the X axis, made up of 128 positions. The Toshiba LCDs are available with differing resolutions.

There are important differences between the KS0108 and T6963 screen formats. The diagrams below show these in more detail: -

The diagram below illustrates the position of one byte at position 0,0 on a KS0108 LCD screen. The least significant bit is located at the top. The byte displayed has a value of 149 (10010101).

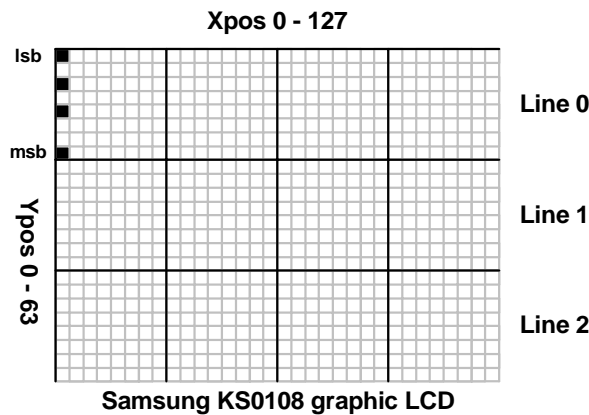

The diagram below illustrates the position of one byte at position 0,0 on a Toshiba T6963 LCD screen in 8-bit font mode. The least significant bit is located at the right of the screen byte. The byte displayed has a value of 149 (10010101).

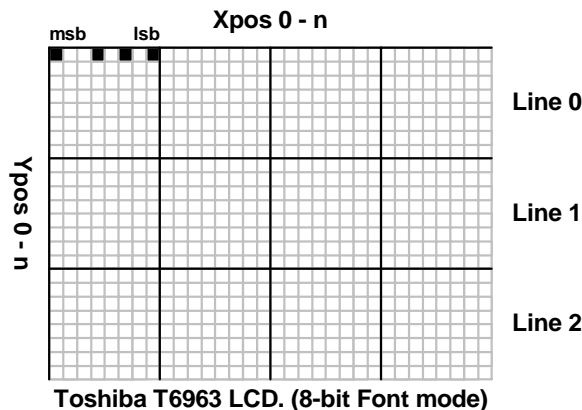

The diagram below illustrates the position of one byte at position 0,0 on a Toshiba T6963 LCD screen in 6-bit font mode. The least significant bit is located at the right of the screen byte. The byte displayed still has a value of 149 (10010101), however, only the first 6 bits are displayed (010101) and the other two are discarded.

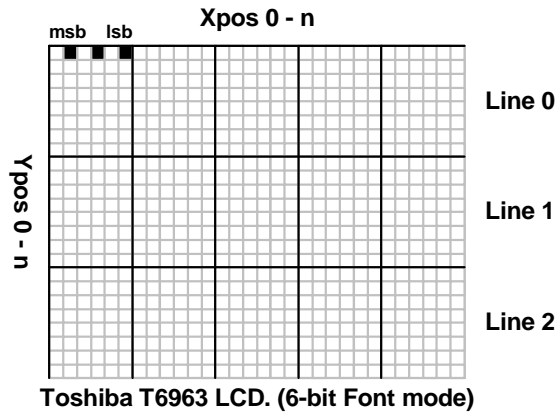

See also : [LCDread](#), [Plot](#), [Toshiba_Command](#), [Toshiba_UDG](#), [UnPlot](#)
see [Print](#) for LCD connections.

Len

Syntax

Assignment Variable = Len(Source String)

Overview

Find the length of a **String**. (not including the null terminator) .

Parameters

Assignment Variable is a user defined variable.

Source String can be a **String** variable, or a Quoted String of Characters. The *Source String* can also be a **Byte**, **Word**, **Float** or **Array** variable, in which case the value contained within the variable is used as a pointer to the start of the Source String's address in RAM. A third possibility for *Source String* is a label name, in which case a null terminated Quoted String of Characters is read from code memory.

Example 1

```
' Display the length of SourceString
Device = 24HJ128GP502
Declare Xtal = 16

Dim SourceString as String * 20 ' Create a String capable of 20 characters
Dim Length as Byte

SourceString = "Hello World" ' Load the source string with characters
Length = Len(SourceString) ' Find the length
Print Dec Length ' Display the result, which will be 11
```

Example 2

```
' Display the length of a Quoted Character String
Device = 24HJ128GP502
Declare Xtal = 16

Dim Length as Byte

Length = Len("Hello World") ' Find the length
Print Dec Length ' Display the result, which will be 11
```

Example 3

```
' Display the length of SourceString using a pointer to SourceString
Device = 24HJ128GP502
Declare Xtal = 16

Dim SourceString as String * 20 ' Create a String capable of 20 characters
Dim Length as Byte ' Display the length of SourceString
Dim SourceString as String * 20 ' Create a String capable of 20 characters
' Create a Word variable to hold the address of SourceString
Dim StringAddr as Word

SourceString = "Hello World" ' Load the source string with characters
' Locate the start address of SourceString in RAM
StringAddr = AddressOf(SourceString)
Length = Len(StringAddr) ' Find the length
Print Dec Length ' Display the result, which will be 11
```

Example 4

```
' Display the length of a code memory string
Device = 24HJ128GP502
Declare Xtal = 16

Dim Length as Byte
,
' Create a null terminated string of characters in code memory
,
Dim Source as Code = "Hello World", 0

Length = Len(Source)      ' Find the length
Print Dec Length         ' Display the result, which will be 11
```

See also : **Creating and using Strings, Creating and using code memory strings, Left\$, Mid\$, Right\$, Str\$, ToLower, ToUpper, AddressOf .**

Left\$

Syntax

Destination String = **Left\$** (*Source String*, *Amount of characters*)

Overview

Extract *n* amount of characters from the left of a source string and copy them into a destination string.

Parameters

Destination String can only be a **String** variable, and should be large enough to hold the correct amount of characters extracted from the *Source String*.

Source String can be a **String** variable, or a Quoted String of Characters. See below for more variable types that can be used for *Source String*.

Amount of characters can be any valid variable type, expression or constant value, that signifies the amount of characters to extract from the left of the *Source String*. Values start at 1 for the leftmost part of the string and should not exceed 255 which is the maximum allowable length of a String variable.

Example 1.

```
' Copy 5 characters from the left of SourceString into DestString
',
Device = 24HJ128GP502
Declare Xtal = 16

Dim SourceString as String * 20 ' Create a String capable of 20 characters
Dim DestString as String * 20 ' Create another String for 20 characters

SourceString = "Hello World" ' Load the source string with characters
',
' Copy 5 characters from the source string into the destination string
',
DestString = Left$(SourceString, 5)
Print DestString ' Display the result, which will be "Hello"
```

Example 2.

```
' Copy 5 chars from the left of a Quoted Character String into DestString
',
Device = 24HJ128GP502
Declare Xtal = 16

Dim DestString as String * 20 ' Create a String capable of 20 characters
',
' Copy 5 characters from the quoted string into the destination string
',
DestString = Left$("Hello World", 5)
Print DestString ' Display the result, which will be "Hello"
```

The *Source String* can also be a **Byte**, **Word**, **Dword**, **Float** or **Array** variable, in which case the value contained within the variable is used as a pointer to the start of the Source String's address in RAM.

Example 3.

```
' Copy 5 characters from the left of SourceString into DestString using a
' pointer to SourceString
,
Device = 24HJ128GP502
Declare Xtal = 16

Dim SourceString as String * 20 ' Create a String capable of 20 characters
Dim DestString as String * 20 ' Create another String for 20 characters
,
' Create a Word variable to hold the address of SourceString
,
Dim StringAddr as Word

SourceString = "Hello World" ' Load the source string with characters
,
' Locate the start address of SourceString in RAM
,
StringAddr = AddressOf(SourceString)
,
' Copy 5 characters from the source string into the destination string
,
DestString = Left$(StringAddr, 5)
Print DestString ' Display the result, which will be "Hello"
```

A third possibility for *Source String* is a label name, in which case a null terminated Quoted String of Characters is read from code memory.

Example 4.

```
' Copy 5 characters from the left of a code memory table into DestString
,
Device = 24HJ128GP502
Declare Xtal = 16

Dim DestString as String * 20 ' Create a String capable of 20 characters
,
' Create a null terminated string of characters in code memory
,
Dim Source as Code = "Hello World", 0
,
' Copy 5 characters from label Source into the destination string
,
DestString = Left$(Source, 5)
Print DestString ' Display the result, which will be "Hello"
```

See also : **Creating and using Strings, Creating and using code memory strings, Len, Mid\$, Right\$, Str\$, ToLower, ToUpper , AddressOf .**

Line

Syntax

Line *Pixel Colour, Xpos Start, Ypos Start, Xpos End, Ypos End*

Overview

Draw a straight line in any direction on a graphic LCD.

Parameters

Pixel Colour may be a constant or variable that determines if the line will set or clear the pixels. A value of 1 will set the pixels and draw a line, while a value of 0 will clear any pixels and erase a line. If using a colour graphic LCD, this parameter holds the 16-bit colour of the pixel.

Xpos Start may be a constant or variable that holds the X position for the start of the line. Can be a value from 0 to the LCD's X resolution.

Ypos Start may be a constant or variable that holds the Y position for the start of the line. Can be a value from 0 to the LCD's Y resolution.

Xpos End may be a constant or variable that holds the X position for the end of the line. Can be a value from 0 to the LCD's X resolution.

Ypos End may be a constant or variable that holds the Y position for the end of the line. Can be a value from 0 to the LCD's Y resolution.

KS0108 graphic LCD example

```
' Draw a line from 0,0 to 120,34
,
Device = 24HJ128GP502
Declare Xtal = 16
,
' LCD interface pin assignments
,
Declare LCD_Type = KS0108      ' Setup for a KS0108 graphic LCD
Declare LCD_DTPort = PORTB.Byte0
Declare LCD_CS1Pin = PORTB.8
Declare LCD_CS2Pin = PORTB.9
Declare LCD_ENPin = PORTB.10
Declare LCD_RSPin = PORTB.11
Declare LCD_RWPin = PORTB.12

Dim Xpos_Start as Byte
Dim Xpos_End as Byte
Dim Ypos_Start as Byte
Dim Ypos_End as Byte
Dim SetClr as Byte

DelayMs 100                      ' Wait for things to stabilise
Cls                               ' Clear the LCD
Xpos_Start = 0
Ypos_Start = 0
Xpos_End = 120
Ypos_End = 34
SetClr = 1
Line SetClr, Xpos_Start, Ypos_Start, Xpos_End, Ypos_End
```

ILI9320 colour graphic LCD example

```
' Demonstrate the Line and LineTo commands with a colour LCD
,
Device = 24EP128MC202
Declare Xtal = 140.03
,
' Setup the Pins used by the ILI9320 graphic LCD
,
Declare LCD_DTPort = PORTB.Byte0 ' Use the first 8-bits of PORTB
Declare LCD_CSPin = PORTB.8 ' Connect to the LCD's CS pin
Declare LCD_RDPin = PORTB.9 ' Connect to the LCD's RD pin
Declare LCD_RSPin = PORTB.10 ' Connect to the LCD's RS pin
Declare LCD_WRPin = PORTA.3 ' Connect to the LCD's WR pin

Include "ILI9320.inc" ' Load the ILI9320 routines into the program

Dim wXpos As Word ' Create a variable for the X position
Dim wYpos As Word ' Create a variable for the Y position

-----
Main:
' Configure the Oscillator to operate the device at 140.03MHz
,
PLL_Setup(76, 2, 2, $0300)

Cls clWhite ' Clear the LCD with the colour white
,
' Draw a series of lines
,
For wYpos = 0 To 319
Line clBrightBlue,0,0,239,wYpos
Next
For wYpos = 0 To 319
Line clBrightRed,239,0,0,wYpos
Next
,
' Draw a box around the LCD using LineTo
,
DelayMS 512
Line clBlack,1,1,238,1
LineTo clBlack,238,318
LineTo clBlack,1,318
LineTo clBlack,1,1
-----
' Configure for internal 7.37MHz oscillator with PLL
' OSC pins are general purpose I/O
,
Config FGS = GWRP_OFF, GCP_OFF
Config FOSCSEL = FNOSC_FRCPLL, IESO_ON, PWMLOCK_OFF
Config FOSC = POSCMD_NONE, OSCIOFNC_ON, IOL1WAY_OFF, FCKSM_CSDCMD
Config FWDT = WDTPOST_PS256, WINDIS_OFF, PLLKEN_ON, FWDTEN_OFF
Config FPOR = ALTI2C1_ON, ALTI2C2_OFF
Config FICD = ICS_PGD1, JTAGEN_OFF
```

Notes.

With an ILI9320 colour graphic LCD, the colour is a 16-bit value formatted in RGB565, where the upper 5-bits represent the red content, the middle 6-bits represent the green content, and the lower 5-bits represent the blue content. As illustrated below:

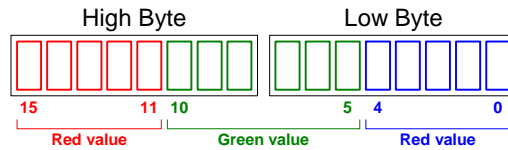

For convenience, there are several colours defined within the ILI9320.inc file. These are:

```
clBlack  
clBrightBlue  
clBrightGreen  
clBrightCyan  
clBrightRed  
clBrightMagenta  
clBrightYellow  
clBlue  
clGreen  
clCyan  
clRed  
clMagenta  
clBrown  
clLightGray  
clDarkGray  
clLightBlue  
clLightGreen  
clLightCyan  
clLightRed  
clLightMagenta  
clYellow  
clWhite
```

More constant values for colours can be added by the user if required.

See Also : **Box, Circle, LintTo, Plot.**

LineTo

Syntax

LineTo *Pixel Colour, Xpos End, Ypos End*

Overview

Draw a straight line in any direction on a graphic LCD, starting from the previous **Line** command's end position.

Parameters

Pixel Colour may be a constant or variable that determines if the line will set or clear the pixels. A value of 1 will set the pixels and draw a line, while a value of 0 will clear any pixels and erase a line. If using a colour graphic LCD, this parameter holds the 16-bit colour of the pixel.

Xpos End may be a constant or variable that holds the X position for the end of the line. Can be a value from 0 to the LCD's X resolution.

Ypos End may be a constant or variable that holds the Y position for the end of the line. Can be a value from 0 to the LCD's Y resolution.

Example

```
' Draw a line from 0,0 to 120,34. Then from 120,34 to 0,63
  Device= 24HJ128GP502
  Declare Xtal = 16
,
' LCD interface pin assignments
,
  Declare LCD_Type = KS0108           ' Setup for a KS0108 graphic LCD
  Declare LCD_DTPort = PORTB.Byte0
  Declare LCD_CS1Pin = PORTB.8
  Declare LCD_CS2Pin = PORTB.9
  Declare LCD_ENPin = PORTB.10
  Declare LCD_RSPin = PORTB.11
  Declare LCD_RWPin = PORTB.12
  Dim Xpos_Start as Byte
  Dim Xpos_End as Byte
  Dim Ypos_Start as Byte
  Dim Ypos_End as Byte
  Dim SetClr as Byte
  DelayMs 100                         ' Wait for things to stabilise
  Cls                                  ' Clear the LCD
  Xpos_Start = 0
  Ypos_Start = 0
  Xpos_End = 120
  Ypos_End = 34
  SetClr = 1
  Line SetClr, Xpos_Start, Ypos_Start, Xpos_End, Ypos_End
  Xpos_End = 0
  Ypos_End = 63
  LineTo SetClr, Xpos_End, Ypos_End
```

Notes.

The **LineTo** command uses the compiler's internal system variables to obtain the end position of a previous **Line** command. These X and Y coordinates are then used as the starting X and Y coordinates of the **LineTo** command.

See Also : **Line, Box, Circle, Plot.**

LoadBit

Syntax

LoadBit *Variable, Index, Value*

Overview

Clear, or Set a bit of a variable or register using a variable index to point to the bit of interest.

Parameters

Variable is a user defined variable, of type **Byte**, **Word**, or **Dword**.

Index is a constant, variable, or expression that points to the bit within *Variable* that requires accessing.

Value is a constant, variable, or expression that will be placed into the bit of interest. Values greater than 1 will set the bit.

Example

```
' Copy variable ExVar bit by bit into variable PT_Var
Device = 24HJ128GP502
Declare Xtal = 16

Dim ExVar as Word
Dim Index as Byte
Dim Value as Byte
Dim PT_Var as Word

Do
  PT_Var = %0000000000000000
  ExVar = %1011011000110111
  Cls
  For Index = 0 to 15          ' Create a loop for 16 bits
    Value = GetBit ExVar, Index ' Examine each bit of variable ExVar
    LoadBit PT_Var, Index, Value ' Set or Clear each bit of PT_Var
    Print At 1,1,Bin16 ExVar    ' Display the original variable
    Print At 2,1,Bin16 PT_Var  ' Display the copied variable
    DelayMs 100                ' Slow things down to see what's happening
  Next                          ' Close the loop
Loop                            ' Do it forever
```

Notes.

There are many ways to clear or set a bit within a variable, however, each method requires a certain amount of manipulation, either with rotates, or alternatively, the use of indirect addressing. Each method has its merits, but requires a certain amount of knowledge to accomplish the task correctly. The **LoadBit** command makes this task extremely simple by taking advantage of the indirect method, however, this is not necessarily the quickest method, or the smallest, but it is the easiest. For speed and size optimisation, there is no shortcut to experience.

To Clear a known constant bit of a variable or register, then access the bit directly using Port.n.
i.e. **PORTA.1 = 0**

To Set a known constant bit of a variable or register, then access the bit directly using Port.n.
i.e. **PORTA.1 = 1**

If a Port is targeted by **LoadBit**, the **TRIS** register is **not** affected.

See also : **ClearBit, GetBit, SetBit.**

LookDown

Syntax

Assignment Variable = **LookDown** *Index*, [*Constant* {, *Constant*...etc }]

Overview

Search *constants*(s) for *index* value. If *index* matches one of the *constants*, then store the matching *constant*'s position (0-N) in *variable*. If no match is found, then the *variable* is unaffected.

Parameters

Assignment Variable is a user define variable that holds the result of the search.

Index is the variable/constant being sought.

Constant(s),... is a list of values. A maximum of 255 values may be placed between the square brackets, 256 if using an 18F device.

Example

```
Device = 24HJ128GP502
Declare Xtal = 16

Dim Value as Byte
Dim MyResult as Byte
Value = 177           ' The value to look for in the list
MyResult = 255       ' Default to value 255
MyResult = LookDown Value, [75,177,35,1,8,29,245]
Print "Value matches ", Dec MyResult, " in list"
```

In the above example, **Print** displays, "Value matches 1 in list" because Value (177) matches item 1 of [75,177,35,1,8,29,245]. Note that index numbers count up from 0, not 1; that is in the list [75,177,35,1,8,29,245], 75 is item 0.

If the value is not in the list, then MyResult is unchanged.

Notes.

LookDown is similar to the index of a book. You search for a topic and the index gives you the page number. Lookdown searches for a value in a list, and stores the item number of the first match in a variable.

LookDown also supports text phrases, which are basically lists of byte values, so they are also eligible for Lookdown searches:

```
Device = 24HJ128GP502
Declare Xtal = 16

Dim Value as Byte = 101           ' ASCII "e". the value to look for in the list
Dim MyResult as Byte = 255       ' Default to value 255

MyResult = LookDown Value, ["Hello World"]
```

In the above example, MyResult will hold a value of 1, which is the position of character 'e'

See also : Dim, cPtr8, cPtr16, cPtr32, Cread8, Cread16, Cread32, Edata, Eread, LookDownL, LookUp, LookUpL.

LookDownL

Syntax

Assignment Variable = **LookDownL** *Index*, {*Operator*} [*Value* {, *Value*...etc }]

Overview

A comparison is made between *index* and *value*; if the result is true, 0 is written into *variable*. If that comparison was false, another comparison is made between *value* and *value1*; if the result is true, 1 is written into variable. This process continues until a true is yielded, at which time the *index* is written into *variable*, or until all entries are exhausted, in which case *variable* is unaffected.

Parameters

Assignment Variable is a user define variable that holds the result of the search.

Index is the variable/constant being sought.

Value(s) can be a mixture of constants, string constants and variables. Expressions may not be used in the *Value* list, although they may be used as the *index* value. A maximum of 65536 values may be placed between the square brackets.

Operator is an optional comparison operator and may be one of the following: -

- = equal
- <> not equal
- > greater than
- < less than
- >= greater than or equal to
- <= less than or equal to

The optional operator can be used to perform a test for other than equal to ("=") while searching the list. For example, the list could be searched for the first *Value* greater than the *index* parameter by using ">" as the *operator*. If *operator* is left out, "=" is assumed.

Example

```
Var1 = LookDownL MyWord, [ 512, MyWord1, 1024 ]  
Var1 = LookDownL MyWord, < [ 10, 100, 1000 ]
```

Notes.

Because **LookDownL** is more versatile than the standard **LookDown** command, it generates larger code. Therefore, if the search list is made up only of 8-bit constants and strings, use **LookDown**.

See also : **Dim, cPtr8, cPtr16, cPtr32, Cread8, Cread16, Cread32, Edata, Eread, LookDown, LookUp, LookUpL.**

LookUp

Syntax

Assignment Variable = **LookUp** *Index*, [*Constant* {, *Constant...etc* }]

Overview

Look up the value specified by the index and store it in variable. If the index exceeds the highest index value of the items in the list, then variable remains unchanged.

Parameters

Assignment Variable may be a constant, variable, or expression. This is where the retrieved value will be stored.

Index may be a constant or variable. This is the item number of the value to be retrieved from the list.

Constant(s) may be any 8-bit value (0-255). A maximum of 65536 values may be placed between the square brackets.

Example

```
' Create an animation of a spinning line on an LCD.
Device = 24HJ128GP502
Declare Xtal = 16

Dim Index as Byte
Dim Frame as Byte

Cls                               ' Clear the LCD
Do
  For Index = 0 to 3              ' Create a loop of 4
    Frame = LookUp Index, [ "|\"-/\" ] ' Table of animation characters
    Print At 1, 1, Frame          ' Display the character
    DelayMs 200                  ' So we can see the animation
  Next                             ' Close the loop
Loop                               ' Repeat forever
```

Notes.

Index starts at value 0. For example, in the **LookUp** command below. If the first value (10) is required, then index will be loaded with 0, and 1 for the second value (20) etc.

```
Var1 = LookUp Index, [10, 20, 30]
```

See also : Dim, cPtr8, cPtr16, cPtr32, Cread8, Cread16, Cread32, Edata, Eread, LookDown, LookDownL, LookUpL.

LookUpL

Syntax

Assignment Variable = **LookUpL** *Index*, [*Value* {, *Value*...etc }]

Overview

Look up the value specified by the index and store it in variable. If the index exceeds the highest index value of the items in the list, then variable remains unchanged. Works exactly the same as **LookUp**, but allows variable types or constants in the list of values.

Parameters

Assignment Variable may be a constant, variable, or expression. This is where the retrieved value will be stored.

Index may be a constant or variable. This is the item number of the value to be retrieved from the list.

Value(s) can be a mixture of 16-bit constants, string constants and variables. A maximum of 65536 values may be placed between the square brackets.

Example

```
Device = 24HJ128GP502
Declare Xtal = 16

Dim Var1 as Byte
Dim MyWord as Word
Dim Index as Byte
Dim Assign as Word

Var1 = 10
MyWord = 1234
Index = 0          ' Point to the first value in the list (MyWord)
Assign = LookUpL Index, [MyWord, Var1, 12345]
```

Notes.

Expressions may not be used in the *Value* list, although they may be used as the *Index* value.

Because **LookUpL** is capable of processing any variable and constant type, the code produced is a lot larger than that of **LookUp**. Therefore, if only 8-bit constants are required in the list, use **LookUp** instead.

See also : **Dim, cPtr8, cPtr16, cPtr32, Cread8, Cread16, Cread32, Edata, Eread, LookDown, LookDownL, LookUp.**

Low

Syntax

Low *Port* or *Port.Bit* or *Pin Number*

Overview

Place a Port or bit in a low state. For a port, this means filling it with 0's. For a bit this means setting it to 0.

Parameters

Port can be any valid port.

Port.Bit can be any valid port and bit combination, i.e. **PORTA.1**

Pin Number can be a variable or constant that holds a value from 0 to the amount of I/O pins on the device. A value of 0 will be **PORTA.0**, if present, 1 will be **PORTA.1**, 16 will be **PORTB.0** etc...

Example 1

```
Device = 24HJ128GP502
Declare Xtal = 16

Symbol LED = PORTB.4
Low LED           ' Clear PORTB bit 4
Low PORTB.0      ' Clear PORTB bit 0
Low PORTB        ' Clear all of PORTB
Low 1            ' Pull Pin PORTA.1 low
```

Example 2

```
' Flash each of the pins on PORTB
,
Device = 24HJ128GP502
Declare Xtal = 16

Dim MyPin as Byte

For MyPin = 16 to 31 ' Create a loop for the pin to flash
  High MyPin        ' Set the pin high
  DelayMs 500       ' Delay so that it can be seen
  Low MyPin         ' Pull the pin low
  DelayMs 500       ' Delay so that it can be seen
Next
```

Notes.

The compiler will write to the device's **LAT** SFR and will always set the relevant Port or Port.Bit to an output.

Each pin number has a designated name. These are Pin_A0, Pin_A1, Pin_A2, Pin_B0...Pin_B15, Pin_C0...Pin_C15, Pin_D0...Pin_D15 to Pin_L15 etc... Each of the names has a relevant value, for example, Pin_A0 has the value 0, Pin_B0 has the value 16, up to Pin_J15, which has the value 143.

These can be used to pass a relevant pin number to a Procedure. For example:

```
,  
' Flash an LED attached to PORTB.0 via a procedure  
' Then flash an LED attached to PORTB.1 via the same procedure  
,  
  
Device = 24HJ128GP502  
Declare Xtal = 16  
  
Do                               ' Create a loop  
    FlashPin(Pin_B0)             ' Call the procedure to flash PORTB.0  
    FlashPin(Pin_B1)             ' Call the procedure to flash PORTB.1  
Loop                               ' Do it forever  
,  
' Set a pin high then low for 500ms using a variable as the pin to adjust  
,  
  
Proc FlashPin(pPinNumber As Byte)  
    High pPinNumber              ' Set the pin output high  
    DelayMs 500                  ' Wait for 500 milliseconds  
    Low pPinNumber               ' Pull the pin output low  
    DelayMs 500                  ' Wait for 500 milliseconds  
EndProc
```

Example 3

```
' Clear then Set each pin of PORTC  
Device = 24HJ128GP502  
Declare Xtal = 16  
  
Dim PinNumber as Byte  
  
Low PORTC                        ' Make PORTC output low before we start  
Do                                ' Create a loop  
    For PinNumber = Pin_C0 to Pin_C7 ' Create a loop for 8 pins  
        Low PinNumber              ' Clear each pin of PORTC  
        DelayMs 100                 ' Slow things down to see what's happening  
    Next                            ' Close the loop  
    For PinNumber = Pin_C0 to Pin_C7 ' Create a loop for 8 pins  
        High PinNumber             ' Set each pin of PORTC  
        DelayMs 100                 ' Slow things down to see what's happening  
    Next                            ' Close the loop  
Loop                               ' Do it forever
```

See also : **ClearPin, Dim, High, SetPin, Symbol.**

Mid\$

Syntax

Destination String = **Mid\$** (*Source String*, *Position within String*, *Amount of characters*)

Overview

Extract *n* amount of characters from a source string beginning at *n* characters from the left, and copy them into a destination string.

Parameters

Destination String can only be a **String** variable, and should be large enough to hold the correct amount of characters extracted from the *Source String*.

Source String can be a **String** variable, or a **Quoted String of Characters**. See below for more variable types that can be used for *Source String*.

Position within String can be any valid variable type, expression or constant value, that signifies the position within the *Source String* from which to start extracting characters. Values start at 1 for the leftmost part of the string and should not exceed 255 which is the maximum allowable length of a *String* variable.

Amount of characters can be any valid variable type, expression or constant value, that signifies the amount of characters to extract from the left of the *Source String*. Values start at 1 and should not exceed 255 which is the maximum allowable length of a *String* variable.

Example 1

```
' Copy 5 characters from position 4 of SourceString into DestString

Device = 24HJ128GP502
Declare Xtal = 16

Dim SourceString as String * 20 ' Create a String of 20 characters
Dim DestString as String * 20   ' Create another String

SourceString = "Hello World"    ' Load the source string with characters
' Copy 5 characters from the source string into the destination string
DestString = Mid$(SourceString, 4, 5)
Print DestString                ' Display the result, which will be "lo Wo"
```

Example 2

```
' Copy 5 chars from position 4 of a Quoted Character String into DestString

Device = 24HJ128GP502
Declare Xtal = 16

Dim DestString as String * 20   ' Create a String of 20 characters

' Copy 5 characters from the quoted string into the destination string
DestString = Mid$("Hello World", 4, 5)
Print DestString                ' Display the result, which will be " lo Wo "
```

The *Source String* can also be a **Byte**, **Word**, **Dword**, **Float** or **Array** variable, in which case the value contained within the variable is used as a pointer to the start of the *Source String*'s address in RAM.

Example 3

```
' Copy 5 chars from position 4 of SourceString to DestString with a pointer
' to SourceString

Device = 24HJ128GP502
Declare Xtal = 16

Dim SourceString as String * 20 ' Create a String of 20 characters
Dim DestString as String * 20   ' Create another String
' Create a Word variable to hold the address of SourceString
Dim StringAddr as Word

SourceString = "Hello World"    ' Load the source string with characters
' Locate the start address of SourceString in RAM
StringAddr = AddressOf(SourceString)
' Copy 5 characters from the source string into the destination string
DestString = Mid$(StringAddr, 4, 5)
Print DestString                ' Display the result, which will be " lo Wo "
```

A third possibility for *Source String* is a Label name, in which case a null terminated Quoted String of Characters is read from code memory.

Example 4

```
' Copy 5 characters from position 4 of a code memory string into DestString

Device = 24HJ128GP502
Declare Xtal = 16

Dim DestString as String * 20    ' Create a String of 20 characters
' Create a null terminated string of characters in code memory
Dim Source as Code = "Hello World", 0

' Copy 5 characters from label Source into the destination string
DestString = Mid$(Source, 4, 5)
Print DestString                  ' Display the result, which will be "LO WO"
```

See also : **Creating and using Strings, Creating and using code memory strings, Len, Left\$, Right\$, Str\$, ToLower, ToUpper, AddressOf .**

On GoTo

Syntax

On *Index Variable* **GoTo** *Label1* {,...*Labeln* }

Overview

Cause the program to jump to different locations based on a variable index.

Parameters

Index Variable is a constant, variable, or expression, that specifies the label to jump to. **Label1...Labeln** are valid labels that specify where to branch to.

Example

```
Device = 24HJ128GP502
Declare Xtal = 16

Dim Index as Byte

Cls                               ' Clear the LCD
Index = 2                          ' Assign Index a value of 2
Start:                             ' Jump to label 2 (Label_2) because Index = 2
  On Index GoTo Label_0, Label_1, Label_2

Label_0:
  Index = 2                        ' Index now equals 2
  Print At 1,1,"Label 0"          ' Display the Label name on the LCD
  DelayMs 500                     ' Wait 500ms
  GoTo Start                      ' Jump back to Start

Label_1:
  Index = 0                        ' Index now equals 0
  Print At 1,1,"Label 1"          ' Display the Label name on the LCD
  DelayMs 500                     ' Wait 500ms
  GoTo Start                      ' Jump back to Start

Label_2:
  Index = 1                        ' Index now equals 1
  Print At 1,1,"Label 2"          ' Display the Label name on the LCD
  DelayMs 500                     ' Wait 500ms
  GoTo Start                      ' Jump back to Start
```

The above example we first assign the index variable a value of 2, then we define our labels. Since the first position is considered 0 and the variable Index equals 2 the **On GoTo** command will cause the program to jump to the third label in the list, which is Label_2.

Notes.

On GoTo is useful when you want to organise a structure such as: -

```
If Var1 = 0 Then GoTo Label_0 ' Var1 = 0: go to label "Label_0"  
If Var1 = 1 Then GoTo Label_1 ' Var1 = 1: go to label "Label_1"  
If Var1 = 2 Then GoTo Label_2 ' Var1 = 2: go to label "Label_2"
```

You can use **On GoTo** to organise this into a single statement: -

```
On Var1 GoTo Label_0, Label_1, Label_2
```

This works exactly the same as the above **If...Then** example. If the value is not in range (in this case if Var1 is greater than 2), **On GoTo** does nothing. The program continues with the next instruction.

See also : **Branch, BranchL, On Gosub.**

On Gosub

Syntax

On *Index Variable* **Gosub** *Label1* {...*Labeln*}

Overview

Cause the program to Call a subroutine based on an index value. A subsequent **Return** will continue the program immediately following the **On Gosub** command.

Parameters

Index Variable is a constant, variable, or expression, that specifies the label to call. **Label1...Labeln** are valid labels that specify where to call.

Example

```
Device = 24HJ128GP502
Declare Xtal = 16

Dim Index as Byte

Cls                                     ' Clear the LCD
While                                   ' Create an infinite loop
  For Index = 0 to 2                   ' Create a loop to call all the labels
    ' Call the label depending on the value of Index
    On Index Gosub Label_0, Label_1, Label_2
    DelayMs 500                        ' Wait 500ms after the subroutine has returned
  Next
Wend                                     ' Do it forever
Label_0:
  Print At 1,1,"Label 0"               ' Display the Label name on the LCD
  Return
Label_1:
  Print At 1,1,"Label 1"               ' Display the Label name on the LCD
  Return
Label_2:
  Print At 1,1,"Label 2"               ' Display the Label name on the LCD
  Return
```

The above example, a loop is formed that will load the variable Index with values 0 to 2. The **On Gosub** command will then use that value to call each subroutine in turn. Each subroutine will **Return** to the **DelayMs** command, ready for the next scan of the loop.

Notes.

On Gosub is useful when you want to organise a structure such as: -

```
If Var1 = 0 Then Gosub Label_0 ' Var1 = 0: call label "Label_0"  
If Var1 = 1 Then Gosub Label_1 ' Var1 = 1: call label "Label_1"  
If Var1 = 2 Then Gosub Label_2 ' Var1 = 2: call label "Label_2"
```

You can use **On Gosub** to organise this into a single statement: -

```
On Var1 Gosub Label_0, Label_1, Label_2
```

This works exactly the same as the above **If...Then** example. If the value is not in range (in this case if Var1 is greater than 2), **On Gosub** does nothing. The program continues with the next instruction..

See also : Branch, BranchL, On GoTo.

Output

Syntax

Output *Port* or *Port . Pin* or *Pin Number*

Overview

Makes the specified *Port* or *Port.Pin* an output.

Parameters

Port.Pin must be a Port.Pin constant declaration.

Pin Number can be any variable or constant holding 0 to the amount of I/O pins on the device. A value of 0 will be **PORTA.0**, if present, 1 will be **PORTA.1**, 8 will be **PORTB.0** etc...

Example 1

```
Output PORTA.0      ' Make bit-0 of PORTA an output
Output PORTA        ' Make all of PORTA an output
Output 0            ' Make pin-0 of PORTA an output
Output 16           ' Make pin-0 of PORTB an output
```

Example 2

```
' Flash each of the pins on PORTB
,
Device = 24HJ128GP502
Declare Xtal = 16

Dim PinNumber as Byte

High PORTB
For PinNumber = 16 to 31      ' Create a loop for the pin to flash
    Output PinNumber         ' Set the pin as an output
    DelayMs 500              ' Delay so that it can be seen
    Input PinNumber          ' Set the pin as an input
    DelayMs 500              ' Delay so that it can be seen
Next
```

Notes.

An Alternative method for making a particular pin an output is by directly modifying the TRIS: -

```
TRISB.0 = 0      ' Make bit-0 of PORTB an output
```

All of the pins on a port may be set to output by setting the whole TRIS register at once: -

```
TRISB = %0000000000000000    ' Set all of PORTB to outputs
```

In the above examples, setting a TRIS bit to 0 makes the pin an output, and conversely, setting the bit to 1 makes the pin an input.

See also : **Input.**

Oread

Syntax

Oread *Pin*, *Mode*, [*Inputdata*]

Overview

Receive data from a device using the Dallas Semiconductor 1-wire protocol. The 1-wire protocol is a form of asynchronous serial communication developed by Dallas Semiconductor. It requires only one I/O pin which may be shared between multiple 1-wire devices.

Parameters

Pin is a Port-Bit combination that specifies which I/O pin to use. 1-wire devices require only one I/O pin (normally called DQ) to communicate. This I/O pin will be toggled between output and input mode during the **Oread** command and will be set to input mode by the end of the **Oread** command.

Mode is a numeric constant (0 - 7) indicating the mode of data transfer. The Mode argument control's the placement of reset pulses and detection of presence pulses, as well as byte or bit input. See notes below.

Inputdata is a list of variables or arrays to store the incoming data into.

Example

```
Device = 24HJ128GP502
Declare Xtal = 16

Dim MyResult as Byte
Symbol DQ = PORTA.0
Oread DQ, 1, [MyResult]
```

The above example code will transmit a 'reset' pulse to a 1-wire device (connected to bit 0 of **PORTA**) and will then detect the device's 'presence' pulse and receive one byte and store it in the variable MyResult.

Notes.

The Mode operator is used to control placement of reset pulses (and detection of presence pulses) and to designate byte or bit input. The table below shows the meaning of each of the 8 possible value combinations for Mode.

Mode Value	Effect
0	No Reset, Byte mode
1	Reset before data, Byte mode
2	Reset after data, Byte mode
3	Reset before and after data, Byte mode
4	No Reset, Bit mode
5	Reset before data, Bit mode
6	Reset after data, Bit mode
7	Reset before and after data, Bit mode

The correct value for Mode depends on the 1-wire device and the portion of the communication that is being dealt with. Consult the data sheet for the device in question to determine the correct value for Mode. In many cases, however, when using the **Oread** command, Mode should be set for either No Reset (to receive data from a transaction already started by an **Owrite**

command) or a Reset after data (to terminate the session after data is received). However, this may vary due to device and application requirements.

When using the Bit (rather than Byte) mode of data transfer, all variables in the InputData argument will only receive one bit. For example, the following code could be used to receive two bits using this mode: -

```
Dim BitVar1 as Bit
Dim BitVar2 as Bit
Oread PORTA.0, 6, [BitVar1, BitVar2]
```

In the example code shown, a value of 6 was chosen for Mode. This sets Bit transfer and Reset after data mode.

We could also have chosen to make the BitVar1 and BitVar2 variables each a Byte type, however, they would still only have received one bit each in the **Oread** command, due to the Mode that was chosen.

The compiler also has a modifier for handling a string of data, named **Str**.

The **Str** modifier is used for receiving data and placing it directly into a byte array variable.

A string is a set of bytes that are arranged or accessed in a certain order. The values 1, 2, 3 would be stored in a string with the value 1 first, followed by 2 then followed by the value 3. A byte array is a similar concept to a string; it contains data that is arranged in a certain order. Each of the elements in an array is the same size. The string 1 2 3 would be stored in a byte array containing three bytes (elements).

Below is an example that receives ten bytes through a 1-wire interface and stores them in the 10-byte array, MyArray: -

```
Dim MyArray[10] as Byte      ' Create a 10-byte array.
Oread DQ, 1, [Str MyArray]
Print Dec Str MyArray       ' Display the values.
```

If the amount of received characters is not enough to fill the entire array, then a formatter may be placed after the array's name, which will only receive characters until the specified length is reached. For example: -

```
Dim MyArray[10] as Byte      ' Create a 10-byte array.
Oread DQ, 1, [Str MyArray\5] ' Fill the first 5-bytes of array with data.
Print Str MyArray \5        ' Display the 5-value string.
```

The example above illustrates how to fill only the first n bytes of an array, and then how to display only the first n bytes of the array. n refers to the value placed after the backslash.

Dallas 1-Wire Protocol.

The 1-wire protocol has a well defined standard for transaction sequences. Every transaction sequence consists of four parts: -

- Initialisation.
- ROM Function Command.
- Memory Function Command.
- Transaction / Data.

Additionally, the ROM Function Command and Memory Function Command are always 8 bits wide and are sent least-significant-bit first (LSB).

The Initialisation consists of a reset pulse (generated by the master) that is followed by a presence pulse (generated by all slave devices).

The reset pulse is controlled by the lowest two bits of the Mode argument in the Oread command. It can be made to appear before the ROM Function Command (Mode = 1), after the Transaction / Data portion (Mode = 2), before and after the entire transaction (Mode = 3) or not at all (Mode = 0).

Command	Value	Action
Read ROM	\$33	Reads the 64-bit ID of the 1-wire device. This command can only be used if there is a single 1-wire device on the line.
Match ROM	\$55	This command, followed by a 64-bit ID, allows the micro-controller to address a specific 1-wire device.
Skip ROM	\$CC	Address a 1-wire device without its 64-bit ID. This command can only be used if there is a single 1-wire device on the line.
Search ROM	\$F0	Reads the 64-bit IDs of all the 1-wire devices on the line. A process of elimination is used to distinguish each unique device.

Following the Initialisation, comes the ROM Function Command. The ROM Function Command is used to address the desired 1-wire device. The above table shows a few common ROM Function Commands. If only a single 1 wire device is connected, the Match ROM command can be used to address it. If more than one 1-wire device is attached, the microcontroller will ultimately have to address them individually using the Match ROM command.

The third part, the Memory Function Command, allows the microcontroller to address specific memory locations, or features, of the 1-wire device. Refer to the 1-wire device's data sheet for a list of the available Memory Function Commands.

Finally, the Transaction / Data section is used to read or write data to the 1-wire device. The **Oread** command will read data at this point in the transaction. A read is accomplished by generating a brief low-pulse and sampling the line within 15us of the falling edge of the pulse. This is called a 'Read Slot'.

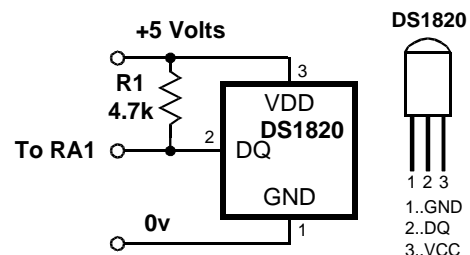

The following program demonstrates interfacing to a Dallas Semiconductor DS1820 1-wire digital thermometer device using the compiler's 1-wire commands, and connections as per the diagram to the right.

The code reads the Counts Remaining and Counts per Degree Centigrade registers within the DS1820 device in order to provide a more accurate temperature (down to 1/10th of a degree).

```
Device = 24HJ128GP502
Declare Xtal = 16

Symbol DQ = PORTA.1           ' Place the DS1820 on bit-1 of PORTA
Dim Temp as Word              ' Holds the temperature value
Dim C as Byte                 ' Holds the counts remaining value
Dim CPerD as Byte             ' Holds the Counts per degree C value

Cls                             ' Clear the LCD before we start
Do
  Owrite DQ, 1, [$CC, $44]     ' Send Calculate Temperature command
  Repeat
    DelayMs 25                 ' Wait until conversion is complete
    Oread DQ, 4, [C]           ' Keep reading low pulses until
  Until C <> 0                  ' the DS1820 is finished.
  Owrite DQ, 1, [$CC, $BE]     ' Send Read ScratchPad command
  Oread DQ, 2, [Temp.LowByte, Temp.HighByte, C, C, C, C, C, CPerD]
  ' Calculate the temperature in degrees Centigrade
  Temp = (((Temp >> 1) * 100) - 25) + (((CPerD - C) * 100) / CPerD)
  Print At 1,1, Dec Temp / 100, ".", Dec2 Temp, " ", At 1,8, "C"
Loop
```

Note.

The equation used in the program above will not work correctly with negative temperatures. Also note that the 4.7k Ω pull-up resistor (R1) is required for correct operation.

Inline Oread Command.

The standard structure of the **Oread** command is: -

```
Oread Pin, Mode, [ Inputdata ]
```

However, this did not allow it to be used in conditions such as **If-Then**, **While-Wend** etc. Therefore, there is now an additional structure to the **Oread** command: -

```
Var = Oread Pin, Mode
```

Parameters Pin and Mode have not changed their function, but the result from the 1-wire read is now placed directly into the assignment variable.

See also : **Owrite.**

Owrite

Syntax

Owrite *Pin, Mode, [OutputData]*

Overview

Send data to a device using the Dallas Semiconductor 1-wire protocol. The 1-wire protocol is a form of asynchronous serial communication developed by Dallas Semiconductor. It requires only one I/O pin which may be shared between multiple 1-wire devices.

Parameters

Pin is a Port-Bit combination that specifies which I/O pin to use. 1-wire devices require only one I/O pin (normally called DQ) to communicate. This I/O pin will be toggled between output and input mode during the Owrite command and will be set to input mode by the end of the Owrite command.

Mode is a numeric constant (0 - 7) indicating the mode of data transfer. The Mode operator controls the placement of reset pulses and detection of presence pulses, as well as byte or bit input. See notes below.

OutputData is a list of variables or arrays transmit individual or repeating bytes.

Example

```
Symbol DQ = PORTA.0
Owrite DQ, 1, [$4E]
```

The above example will transmit a 'reset' pulse to a 1-wire device (connected to bit 0 of PORTA) and will then detect the device's 'presence' pulse and transmit one byte (the value \$4E).

Notes.

The Mode operator is used to control placement of reset pulses (and detection of presence pulses) and to designate byte or bit input. The table below shows the meaning of each of the 8 possible value combinations for Mode.

Mode Value	Effect
0	No Reset, Byte mode
1	Reset before data, Byte mode
2	Reset after data, Byte mode
3	Reset before and after data, Byte mode
4	No Reset, Bit mode
5	Reset before data, Bit mode
6	Reset after data, Bit mode
7	Reset before and after data, Bit mode

The correct value for Mode depends on the 1-wire device and the portion of the communication you're dealing with. Consult the data sheet for the device in question to determine the correct value for Mode. In many cases, however, when using the **Owrite** command, Mode should be set for a Reset before data (to initialise the transaction). However, this may vary due to device and application requirements.

When using the Bit (rather than Byte) mode of data transfer, all variables in the InputData argument will only receive one bit. For example, the following code could be used to receive two bits using this mode: -

```
Dim BitVar1 as Bit
Dim BitVar2 as Bit
Owrite PORTA.0, 6, [BitVar1, BitVar2]
```

In the example code shown, a value of 6 was chosen for Mode. This sets Bit transfer and Reset after data mode. We could also have chosen to make the BitVar1 and BitVar2 variables each a Byte type, however, they would still only use their lowest bit (Bit0) as the value to transmit in the **Owrite** command, due to the Mode value chosen.

The Str Modifier

The **Str** modifier is used for transmitting a string of bytes from a byte array variable. A string is a set of bytes sized values that are arranged or accessed in a certain order. The values 1, 2, 3 would be stored in a string with the value 1 first, followed by 2 then followed by the value 3. A byte array is a similar concept to a string; it contains data that is arranged in a certain order. Each of the elements in an array is the same size. The string 1,2,3 would be stored in a byte array containing three bytes (elements).

Below is an example that sends four bytes (from a byte array) through bit-0 of PORTA: -

```
Dim MyArray[10] as Byte           ' Create a 10-byte array.
MyArray [0] = $CC                 ' Load the first 4 bytes of the array
MyArray [1] = $44                 ' With the data to send
MyArray [2] = $CC
MyArray [3] = $4E
Owrite PORTA.0, 1, [Str MyArray\4] ' Send 4-byte string.
```

Note that we use the optional \n argument of **Str**. If we didn't specify this, the microcontroller would try to keep sending characters until all 10 bytes of the array were transmitted. Since we do not wish all 10 bytes to be transmitted, we chose to tell it explicitly to only send the first 4 bytes.

The above example may also be written as: -

```
Dim MyArray[10] as Byte           ' Create a 10-byte array.
Str MyArray = $CC,$44,$CC,$4E     ' Load the first 4 bytes of the array
Owrite PORTA.0, 1, [Str MyArray\4] ' Send 4-byte string.
```

The above example, has exactly the same function as the previous one. The only difference is that the string is now constructed using the **Str** as a command instead of a modifier.

See also : [Oread for example code, and 1-wire protocol.](#)

Pixel

Syntax

Assignment Variable = **Pixel** *Ypos*, *Xpos*

Overview

Read the condition of an individual pixel from a graphic LCD. The returned value will be 1 if the pixel is set, and 0 if the pixel is clear, or if using a colour graphic LCD, it will hold the 16-bit colour of the pixel.

Parameters

Assignment Variable is a user defined variable that holds the colour of the pixel.

Xpos can be a constant, variable, or expression, pointing to the X-axis location of the pixel to examine. This must be a value of 0 to the X resolution of the LCD. Where 0 is the far left row of pixels.

Ypos can be a constant, variable, or expression, pointing to the Y-axis location of the pixel to examine. This must be a value of 0 to the Y resolution of the LCD. Where 0 is the top column of pixels.

Example

```
' Read a line of pixels from a KS0108 graphic LCD
Device = 24HJ128GP502
Declare Xtal = 16
'
' KS0108 graphic LCD declares
'
Declare LCD_Type = KS0108          ' Setup for a KS0108 graphic LCD
Declare LCD_DTPort = PORTB.Byte0
Declare LCD_CS1Pin = PORTB.8
Declare LCD_CS2Pin = PORTB.9
Declare LCD_ENPin = PORTB.10
Declare LCD_RSPin = PORTB.11
Declare LCD_RWPin = PORTB.12

Dim Xpos as Byte
Dim Ypos as Byte
Dim MyResult as Byte

Cls
Print At 0, 0, "Testing 1-2-3"
' Read the top row and display the result
For Xpos = 0 to 127
    MyResult = Pixel 0, Xpos          ' Read the top row
    Print At 1, 0, Dec MyResult
    DelayMs 400
Next
```

See also : LCDread, LCDwrite, Plot, UnPlot. See Print for circuit.

Plot

Syntax

Plot *Ypos*, *Xpos*

Overview

Set an individual pixel on a graphic LCD.

Parameters

Xpos can be a constant, variable, or expression, pointing to the X-axis location of the pixel to set. This must be a value of 0 to the X resolution of the LCD. Where 0 is the far left row of pixels.

Ypos can be a constant, variable, or expression, pointing to the Y-axis location of the pixel to set. This must be a value of 0 to the Y resolution of the LCD. Where 0 is the top column of pixels.

KS0108 LCD example

```
Device = 24HJ128GP502
Declare Xtal = 16
,
' KS0108 graphic LCD declares
,
Declare LCD_Type = KS0108 ' Setup for a KS0108 graphic LCD
Declare LCD_DTPort = PORTB.Byte0
Declare LCD_CS1Pin = PORTB.8
Declare LCD_CS2Pin = PORTB.9
Declare LCD_ENPin = PORTB.10
Declare LCD_RSPin = PORTB.11
Declare LCD_RWPin = PORTB.12

Dim Xpos as Byte
,
' Draw a line across the LCD
,
While ' Create an infinite loop
    For Xpos = 0 to 127
        Plot 20, Xpos
        DelayMs 10
    Next
    ,
    ' Now erase the line
    ,
    For Xpos = 0 to 127
        UnPlot 20, Xpos
        DelayMs 10
    Next
Wend
```

ILI9320 colour graphic LCD example

```
' Fill the LCD with colour using plot
,
Device = 24EP128MC202
Declare Xtal = 140.03
,
' Setup the Pins used by the ILI9320 320x240 pixel graphic LCD
,
Declare LCD_DTPort = PORTB.Byte0 ' Use the first 8-bits of PORTB
Declare LCD_CSPin = PORTB.8 ' Connect to the LCD's CS pin
Declare LCD_RDPin = PORTB.9 ' Connect to the LCD's RD pin
Declare LCD_RSPin = PORTB.10 ' Connect to the LCD's RS pin
Declare LCD_WRPin = PORTA.3 ' Connect to the LCD's WR pin

Include "ILI9320.inc" ' Load the ILI9320 routines into the program

Dim wXpos As Word ' Create a variable for the X position
Dim wYpos As Word ' Create a variable for the Y position
-----
Main:
' Configure the internal oscillator to operate the device at 140.03MHz
PLL_Setup(76, 2, 2, $0300)

Cls clYellow ' Clear the LCD with the colour yellow
Glcd_InkColour(clBrightBlue) ' Choose the pixel colour
,
' Fill the LCD with colour
,
For wYpos = 0 To 319
For wXpos = 0 To 239
Plot wYpos, wXpos
Next
Next
-----
' Configure for internal 7.37MHz oscillator with PLL
' OSC pins are general purpose I/O
,
Config FGS = GWRP_OFF, GCP_OFF
Config FOSCSEL = FNOSC_FRCPLL, IESO_ON, PWMLOCK_OFF
Config FOSC = POSCMD_NONE, OSCIOFNC_ON, IOL1WAY_OFF, FCKSM_CSDCMD
Config FWDT = WDTPOST_PS256, WINDIS_OFF, PLLKEN_ON, FWDTEN_OFF
Config FPOR = ALTI2C1_ON, ALTI2C2_OFF
Config FICD = ICS_PGD1, JTAGEN_OFF
```

Notes.

If using a colour graphic LCD, the **Plot** command will use the current colour of the pixel's Ink. As previously set by the **Glcd_Ink** command.

With an ILI9320 320x240 pixel colour graphic LCD, the colour is a 16-bit value formatted in RGB565, where the upper 5-bits represent the red content, the middle 6-bits represent the green content, and the lower 5-bits represent the blue content. As illustrated below:

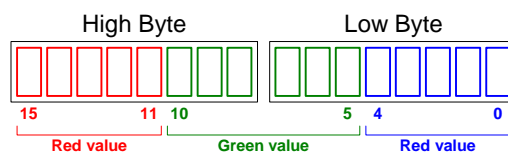

See also : **LCDread, LCDwrite, Pixel, UnPlot.**

Graphic LCD pixel configuration for a 128x64 resolution display.

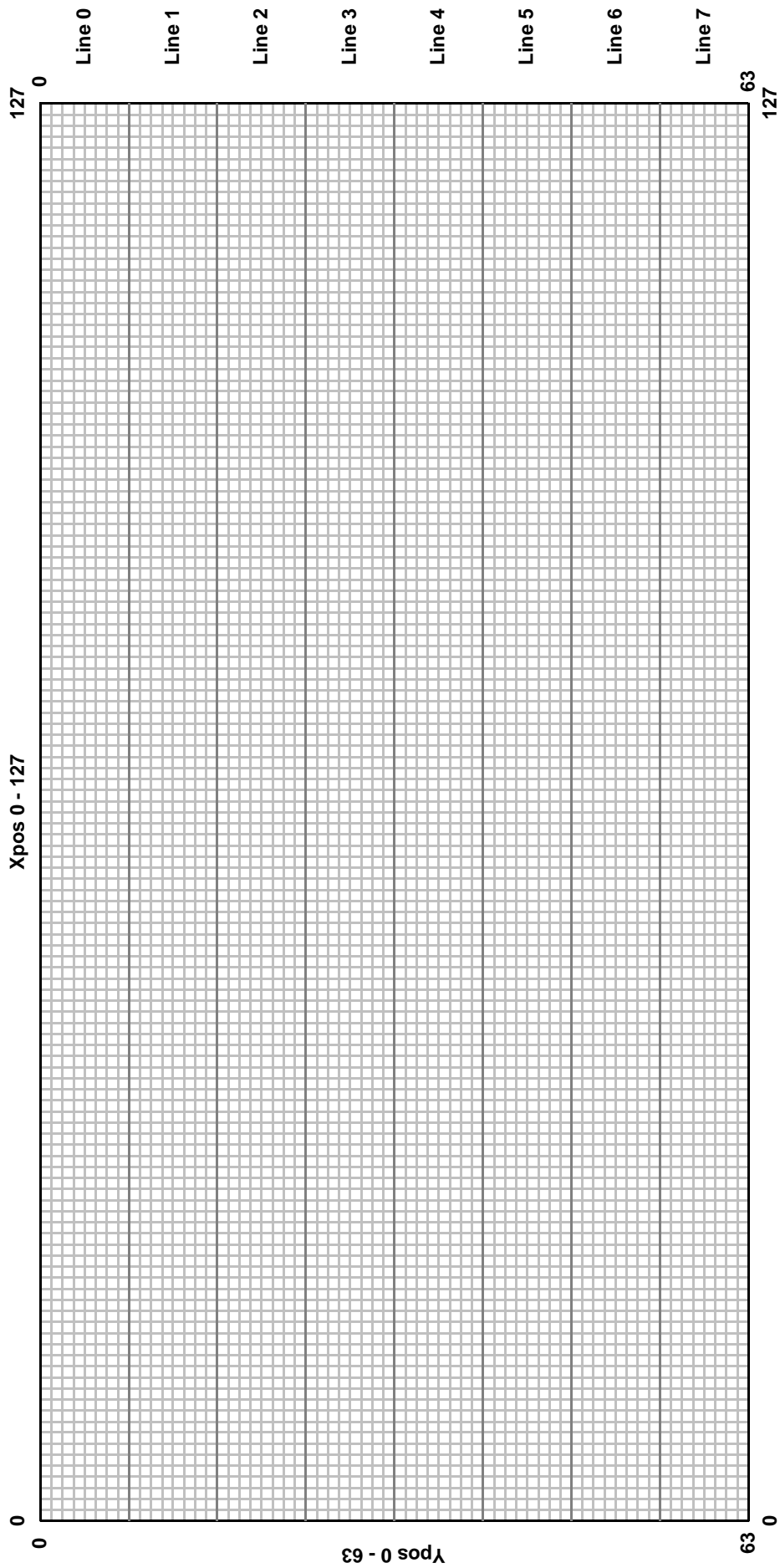

Pop

Syntax

Pop *Variable*, {*Variable*, *Variable* etc}

Overview

Pull a single variable or multiple variables from the microcontroller's stack.

Parameters

Variable is a user defined variable of type **Bit**, **Byte**, **Word**, **Dword**, **Float**, **Array**, or **String**.

The amount of bytes pushed on to the stack varies with the variable type used. The list below shows how many bytes are pushed for a particular variable type, and their order. The microcontroller's stack is word orientated, therefore all operations are accomplished using 16-bits.

Bit	2 Bytes are popped containing the value of the bit pushed.
Byte	2 Bytes are popped containing the value of the byte pushed.
Byte Array	2 Bytes are popped containing the value of the byte pushed.
Word	2 Bytes are popped. Low Byte then High Byte containing the value of the word pushed.
Word Array	2 Bytes are popped. Low Byte then High Byte containing the value of the word pushed.
Dword Array	4 Bytes are popped. Low Byte, Mid1 Byte, Mid2 Byte then High Byte containing the value of the dword pushed.
Float Array	4 Bytes are popped. Low Byte, Mid1 Byte, Mid2 Byte then High Byte containing the value of the dword pushed.
Dword	4 Bytes are popped. Low Byte, Mid1 Byte, Mid2 Byte then High Byte containing the value of the dword pushed.
Float	4 Bytes are popped. Low Byte, Mid1 Byte, Mid2 Byte then High Byte containing the value of the float pushed.
String	2 Bytes are popped. Low Byte then High Byte that point to the start address of the string previously pushed.

Example 1

' Push two variables on to the stack then retrieve them

```
Device = 24HJ128GP502
Declare Xtal = 16
Declare Stack_Size = 90      ' Increase the stack to hold extra words

Dim MyWord as Word          ' Create a Word variable
Dim MyDword as Dword        ' Create a Dword variable

MyWord = 1234                ' Load the Word variable with a value
MyDword = 567890            ' Load the Dword variable with a value
Push MyWord, MyDword        ' Push the Word variable then the Dword variable

Clear MyWord                ' Clear the Word variable
Clear MyDword               ' Clear the Dword variable

Pop MyDword, MyWord         ' Pop the Dword variable then the Word variable
Print Dec MyWord, " ", Dec MyDword ' Display the variables as decimal
```

Example 2

```
' Push a String on to the stack then retrieve it

Device = 24HJ128GP502
Declare Xtal = 16
Declare Stack_Size = 90          ' Increase the stack to hold extra words

Dim SourceString as String * 20 ' Create a String variable
Dim DestString as String * 20   ' Create another String variable

SourceString = "Hello World"    ' Load the String variable with characters

Push SourceString              ' Push the String variable's address

Pop DestString                 ' Pop the previously pushed String into DestString
Print DestString               ' Display the string, which will be "Hello World"
```

Example 3

```
' Push a Quoted character string on to the stack then retrieve it

Device = 24HJ128GP502
Declare Xtal = 16
Declare Stack_Size = 90          ' Increase the stack to hold extra words

Dim DestString as String * 20    ' Create a String variable

Push "Hello World"              ' Push the Quoted String of Characters on to the stack

Pop DestString                  ' Pop the previously pushed String into DestString
Print DestString               ' Display the string, which will be "Hello World"
```

Notes.

Unlike the 8-bit PIC[®] microcontroller's, the PIC24[®] and dsPIC33[®] types have a true stack that occupied RAM and stores call and return data as well as data pushed onto it. This is a valuable resource for saving and restoring variables or SFRs than would otherwise be altered.

There are two declares for use with the stack. These are:

Declare Stack_Size = 20 to n (in words)

The compiler sets the default size of the microcontroller's stack to 60 words (120 bytes). This can be increased or decreased as required, as long as it fits within the RAM available. The compiler places a minimum limit of 20 for stack size. If the stack overflows or underflows, the microcontroller will trigger an exception.

Declare Stack_Expand = 1 or 0 or On or Off

Whenever an interrupt handler is used within a BASIC program, it must context save and restore critical SFRs and variables that would otherwise get overwritten. It uses the microcontroller's stack for temporary storage of the SFRs and variables, therefore the stack will increase with every interrupt handler used within the program. If this behaviour is undesirable, the above declare will disable it. However, the user must make sure that the stack is large enough to accommodate the storage, otherwise an exception will be triggered by the microcontroller.

See also : Push.

Pot

Syntax

Assignment Variable = **Pot** *Pin*, *Scale*

Overview

Read a potentiometer, thermistor, photocell, or other variable resistance.

Parameters

Assignment Variable is a user defined variable.

Pin is a Port.Pin constant that specifies the I/O pin to use.

Scale is a constant, variable, or expression, used to scale the instruction's internal 16-bit result. The 16-bit reading is multiplied by (scale/ 256), so a *scale* value of 128 would reduce the range by approximately 50%, a scale of 64 would reduce to 25%, and so on.

Example

```
Device = 24HJ128GP502
Declare xtal = 16

Dim Var1 as Byte
While                                     ' Create an infinite loop
    Var1 = Pot PORTB.0, 100               ' Read potentiometer on pin 0 of PORTB.
    Print Dec Var1, " "                  ' Display the potentiometer reading
Wend                                       ' Do it forever
```

Notes.

Internally, the **Pot** instruction calculates a 16-bit value, which is scaled down to an 8-bit value. The amount by which the internal value must be scaled varies with the size of the resistor being used.

The pin specified by **Pot** must be connected to one side of a resistor, whose other side is connected through a capacitor to ground. A resistance measurement is taken by timing how long it takes to discharge the capacitor through the resistor.

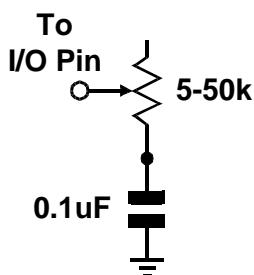

The value of *scale* must be determined by experimentation, however, this is easily accomplished as follows: -

Set the device under measure, the pot in this instance, to maximum resistance and read it with *scale* set to 255. The value returned in *Var1* can now be used as *scale*: -

```
Var1 = Pot PORTB.0, 255
```

See also : Adin, RCin.

Print

Syntax

Print *Item* {, *Item*... }

Overview

Send Text to an LCD module using the Hitachi HD44780 controller or a graphic LCD based on the KS0108, or Toshiba T6963, or ILI9320 chipsets.

Parameters

Item may be a constant, variable, expression, modifier, or string list.

There are no operands as such, instead there are *modifiers*. For example, if an at sign '@' precedes an *Item*, the ASCII representation for each digit is sent to the LCD.

The modifiers are listed below: -

Modifier

Operation

At ypos (1 to n),xpos(1 to n) Position the cursor on the LCD

Cl Clear the LCD (also creates a 30ms delay)

Bin{1..32}

Display binary digits

Dec{1..10}

Display decimal digits

Hex{1..8}

Display hexadecimal digits

Sbin{1..32}

Display signed binary digits

Sdec{1..10}

Display signed decimal digits

Shex{1..8}

Display signed hexadecimal digits

lbin{1..32}

Display binary digits with a preceding '%' identifier

ldec{1..10}

Display decimal digits with a preceding '#' identifier

lhex{1..8}

Display hexadecimal digits with a preceding '\$' identifier

lSbin{1..32}

Display signed binary digits with a preceding '%' identifier

lSdec{1..10}

Display signed decimal digits with a preceding '#' identifier

lShex{1..8}

Display signed hexadecimal digits with a preceding '\$' identifier

Rep c\n

Display character c repeated n times

Str array\n

Display all or part of an array

Cstr Label

Display string data defined in code memory.

The numbers after the **Bin**, **Dec**, and **Hex** modifiers are optional. If they are omitted, then the default is all the digits that make up the value will be displayed.

If a floating point variable is to be displayed, then the digits after the **Dec** modifier determine how many remainder digits are printed. i.e. numbers after the decimal point.

```
Dim MyFloat as Float
MyFloat = 3.145
Print Dec2 MyFloat      ' Display 2 values after the decimal point
```

The above program will display 3.14

If the digit after the **Dec** modifier is omitted, then 3 values will be displayed after the decimal point.

```
Dim MyFloat as Float
MyFloat = 3.1456
Print Dec MyFloat      ' Display 3 values after the decimal point
```

The above program will display 3.145

There is no need to use the **Sdec** modifier for signed floating point values, as the compiler's **Dec** modifier will automatically display a minus result: -

```
Dim MyFloat as Float
MyFloat = -3.1456
Print Dec MyFloat      ' Display 3 values after the decimal point
```

The above program will display -3.145

Hex or **Bin** modifiers cannot be used with floating point values or variables.

The Xpos and Ypos values in the **At** modifier both start at 1. For example, to place the text "Hello World" on line 1, position 1, the code would be: -

```
Print At 1, 1, "Hello World"
```

Example 1

```
Device = 24HJ128GP502
Declare Xtal = 16
```

```
Dim Var1 as Byte
Dim MyWord as Word
Dim MyDword as Dword
```

```
Print "Hello World"      ' Display the text "Hello World"
Print "Var1= ", Dec Var1 ' Display the decimal value of Var1
Print "Var1= ", Hex Var1 ' Display the hexadecimal value of Var1
Print "Var1= ", Bin Var1 ' Display the binary value of Var1
Print "MyDword= ", Hex6 MyDword ' Display 6 hex characters of a Dword variable
```

Example 2

```
' Display a negative value on the LCD.
Symbol Negative = -200
Print At 1, 1, Sdec Negative
```

Example 3

```
' Display a negative value on the LCD with a preceding identifier.
Print At 1, 1, IShex -$1234
```

Example 3 will produce the text "\$-1234" on the LCD.

The **Cstr** modifier is used in conjunction with code memory strings. The **Dim as Code** directive is used for initially creating the string of characters: -

```
Dim CodeString as Code = "Hello World", 0
```

The above line of code will create, in code memory, the values that make up the ASCII text "Hello World", at address String1. Note the null terminator after the ASCII text.

Null terminated means that a zero (null) is placed at the end of the string of ASCII characters to signal that the string has finished.

To display this string of characters, the following command structure could be used: -

```
Print CodeString
```

The label that declared the address where the list of code memory values resided, now becomes the string's name.

The **Str** modifier is used for sending a string of bytes from a byte array variable. A string is a set of bytes sized values that are arranged or accessed in a certain order. The values 1, 2, 3 would be stored in a string with the value 1 first, followed by 2 then followed by the value 3. A byte array is a similar concept to a string; it contains data that is arranged in a certain order. Each of the elements in an array is the same size. The string 1,2,3 would be stored in a byte array containing three bytes (elements).

Below is an example that displays four bytes (from a byte array): -

```
Dim MyArray[10] as Byte      ' Create a 10-byte array.
MyArray [0] = "H"           ' Load the first 5 bytes of the array
MyArray [1] = "E"           ' With the data to send
MyArray [2] = "L"
MyArray [3] = "L"
MyArray [4] = "O"
Print Str MyArray\5         ' Display a 5-byte string.
```

Note that we use the optional \n argument of **Str**. If we didn't specify this, the microcontroller would try to keep sending characters until all 10 bytes of the array were transmitted. Since we do not wish all 10 bytes to be transmitted, we chose to tell it explicitly to only send the first 5 bytes.

The above example may also be written as: -

```
Dim MyArray[10] as Byte      ' Create a 10-byte array.
Str MyArray = "Hello"        ' Load the first 5 bytes of the array
Print Str MyArray\5         ' Send 5-byte string.
```

The above example, has exactly the same function as the previous one. The only difference is that the string is now constructed using **Str** as a command instead of a modifier.

Declares

There are several Declares for use with an alphanumeric LCD and **Print**: -

Declare LCD_Type 0 or 1 or 2, **Alpha** or **Graphic** or **KS0108** or **Toshiba** or **T6963**

Inform the compiler as to the type of LCD that the **Print** command will output to. If **Graphic**, **KS0108** or 1 is chosen then any output by the **Print** command will be directed to a graphic LCD based on the KS0108 chipset. A value of 2, or the text **Toshiba**, or **T6963**, will direct the output to a graphic LCD based on the Toshiba T6963 chipset. A value of 0 or **Alpha**, or if the **Declare** is not issued, will target the standard Hitachi HD44780 alphanumeric LCD type

Targeting the graphic LCD will also enable commands such as **Plot**, **UnPlot**, **LCDread**, **LCDwrite**, **Pixel**, **Box**, **Circle** and **Line**.

Declare LCD_DTPin Port . Pin

Assigns the Port and Pins that the LCD's DT (data) lines will attach to.

The LCD may be connected to the microcontroller using either a 4-bit bus or an 8-bit bus. If an 8-bit bus is used, all 8 bits must be on one port. If a 4-bit bus is used, it must be connected to either the bottom 4 or top 4 bits of one port. For example: -

```
Declare LCD_DTPin PORTB.4      ' Used for 4-line interface.
```

```
Declare LCD_DTPin PORTB.0      ' Used for 8-line interface.
```

In the previous examples, PORTB is only a personal preference. The LCD's DT lines may be attached to any valid port on the microcontroller.

There is no default setting for this **Declare** and it must be used within the BASIC program.

Declare LCD_ENPin Port . Pin

Assigns the Port and Pin that the LCD's EN line will attach to.

There is no default setting for this **Declare** and it must be used within the BASIC program.

Declare LCD_RSPin Port . Pin

Assigns the Port and Pins that the LCD's RS line will attach to.

There is no default setting for this **Declare** and it must be used within the BASIC program.

Declare LCD_Interface 4 or 8

Inform the compiler as to whether a 4-line or 8-line interface is required by the LCD.

There is no default setting for this **Declare** and it must be used within the BASIC program.

Declare LCD_Lines 1, 2, or 4

Inform the compiler as to how many lines the LCD has.

LCD's come in a range of sizes, the most popular being the 2 line by 16 character types. However, there are 4 line types as well. Simply place the number of lines that the particular LCD has, into the declare.

There is no default setting for this **Declare** and it must be used within the BASIC program.

Notes.

If no modifier precedes an item in a **Print** command, then the character's value is sent to the LCD. This is useful for sending control codes to the LCD. For example: -

```
Print $FE, 128
```

Will move the cursor to line 1, position 1 (HOME).

Below is a list of some useful control commands: -

Control Command	Operation
\$FE, 1	Clear display
\$FE, 2	Return home (beginning of first line)
\$FE, \$0C	Cursor off
\$FE, \$0E	Underline cursor on
\$FE, \$0F	Blinking cursor on
\$FE, \$10	Move cursor left one position
\$FE, \$14	Move cursor right one position
\$FE, \$C0	Move cursor to beginning of second line
\$FE, \$94	Move cursor to beginning of third line (if applicable)
\$FE, \$D4	Move cursor to beginning of fourth line (if applicable)

Note that if the command for clearing the LCD is used, then a small delay should follow it: -

```
Print $FE, 1 : DelayMs 10
```

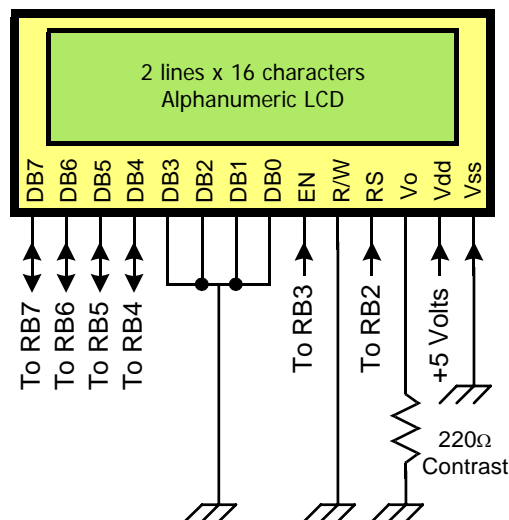

The above diagram shows typical connections for an alphanumeric LCD module using a 4-bit interface. Note that the compiler does not use the LCD's RW pin, and this must be connected to ground.

Using a KS0108 Graphic LCD

Once a KS0108 graphic LCD has been chosen using the **Declare LCD_Type** directive, all **Print** outputs will be directed to that LCD.

The standard modifiers used by an alphanumeric LCD may also be used with the graphics LCD. Most of the above modifiers still work in the expected manner, however, the **At** modifier now starts at Ypos 0 and Xpos 0, where values 0,0 will be the top left corner of the LCD.

There are also four new modifiers. These are: -

Inverse 0-1	Invert the characters sent to the LCD
Or 0-1	Or the new character with the original
Xor 0-1	Xor the new character with the original

Once one of the four new modifiers has been enabled, all future **Print** commands will use that particular feature until the modifier is disabled. For example: -

```
' Enable inverted characters from this point
Print At 0, 0, Inverse 1, "Hello World"
Print At 1, 0, "Still Inverted"
' Now use normal characters
Print At 2, 0, Inverse 0, "Normal Characters"
```

If no modifiers are present, then the character's ASCII representation will be displayed: -

```
' Print characters A and B
Print At 0, 0, 65, 66
```

KS0108 graphic LCD Declares

There are several declares associated with a KS0108 graphic LCD.

Declare LCD_DTPort Port = Port.Byten

Assign the port that will output the 8-bit data to the graphic LCD.

There is no default setting for this **Declare** and it must be used within the BASIC program.

Declare LCD_RWPin = Port . Pin

Assigns the Port and Pin that the graphic LCD's RW line will attach to.

There is no default setting for this **Declare** and it must be used within the BASIC program.

Declare LCD_ENPin Port . Pin

Assigns the Port and Pin that the LCD's EN line will attach to.

There is no default setting for this **Declare** and it must be used within the BASIC program.

Declare LCD_RSPin Port . Pin

Assigns the Port and Pins that the LCD's RS line will attach to.

There is no default setting for this **Declare** and it must be used within the BASIC program.

Declare LCD_CS1Pin = Port . Pin

Assigns the Port and Pin that the graphic LCD's CS1 line will attach to.

There is no default setting for this **Declare** and it must be used within the BASIC program.

Declare LCD_CS2Pin = Port . Pin

Assigns the Port and Pin that the graphic LCD's CS2 line will attach to.

There is no default setting for this **Declare** and it must be used within the BASIC program.

Note

The KS0108 graphic LCD is a “non-intelligent” type, therefore, a separate character set is required. This is held internally in code memory.

The code memory table that contains the font must have a label named **Font_Table**. For example: -

```
{ data for characters 0 to 64 here}
  Dim Font_Table as Code = $7E, $11, $11, $11, $7E, $00, _ ' Chr 65 "A"
                          $7F, $49, $49, $49, $36, $00, _ ' Chr 66 "B"
  { rest of font table }
```

The font is built up of an 8x6 cell, with only 5 of the 6 rows, and 7 of the 8 columns being used for alphanumeric characters. See the diagram below.

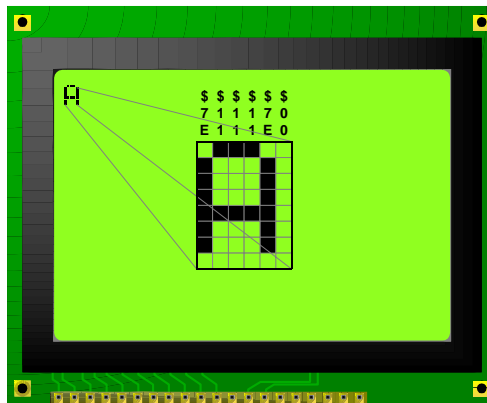

If a graphic character is chosen (chr 0 to 31), the whole of the 8x6 cell is used. In this way, large fonts and graphics may be easily constructed.

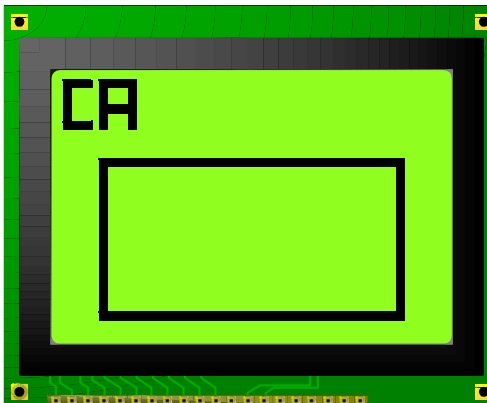

The character set itself is 128 characters long (0 -127). Which means that all the ASCII characters are present, including \$, %, &, # etc.

Declare GLCD_CS_Invert On - Off, 1 or 0

Some graphic LCD types have inverters on the CS lines. Which means that the LCD displays left-hand data on the right side, and vice-versa. The **GLCD_CS_Invert Declare**, adjusts the library LCD handling subroutines to take this into account.

Declare GLCD_Strobe_Delay 0 to 16383 cycles.

If a noisy circuit layout is unavoidable when using a graphic LCD, then the above **Declare** may be used. This will create a delay between the Enable line being strobed. This can ease random data being produced on the LCD's screen. See below for more details on circuit layout for graphic LCDs.

If the **Declare** is not used in the program, then the cycles delay is determined by the oscillator used.

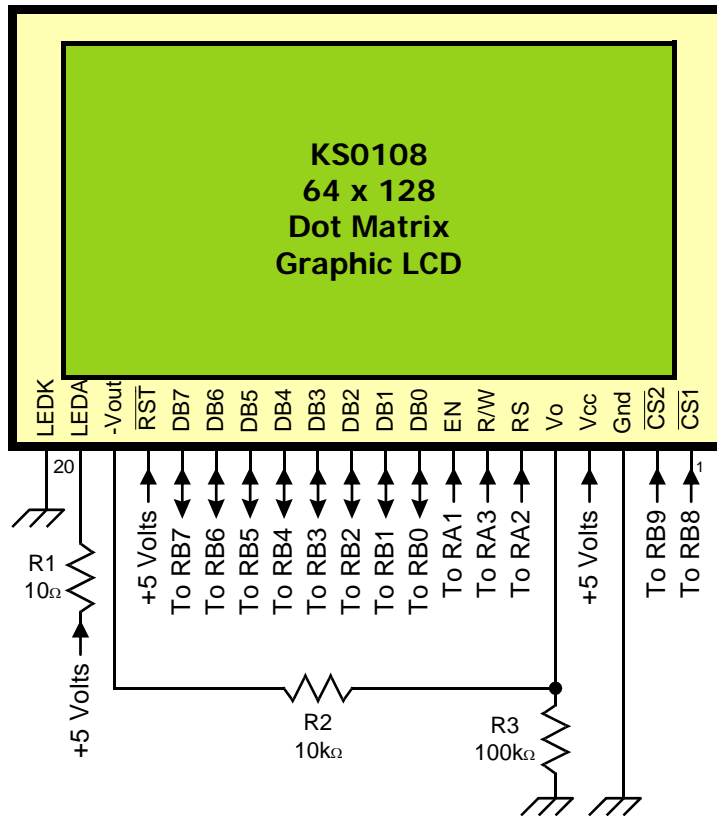

The diagram above shows typical connections to a KS0108 graphic LCD.

Using a Toshiba T6963 Graphic LCD

Once a Toshiba T6963 graphic LCD has been chosen using the **Declare LCD_Type** directive, all **Print** outputs will be directed to that LCD. Note that the Toshiba routines must be loaded into the program via the **Include** directive.

The standard modifiers used by an alphanumeric LCD may also be used with the graphics LCD. Most of the modifiers still work in the expected manner, however, the **At** modifier now starts at Ypos 0 and Xpos 0, where values 0,0 correspond to the top left corner of the LCD.

The KS0108 modifiers **Inverse**, **Or**, and **Xor** are not supported because of the method Toshiba LCD's using the T6963 chipset implement text and graphics.

There are several **Declares** for use with a Toshiba graphic LCD, some optional and some mandatory.

Declare LCD_DTPort = Port

Assign the port that will output the 8-bit data to the graphic LCD.

There is no default setting for this **Declare** and it must be used within the BASIC program.

Declare LCD_WRPin Port . Pin

Assigns the Port and Pin that the graphic LCD's WR line will attach to.

There is no default setting for this **Declare** and it must be used within the BASIC program.

Declare LCD_RDPin Port . Pin

Assigns the Port and Pin that the graphic LCD's RD line will attach to.

There is no default setting for this **Declare** and it must be used within the BASIC program.

Declare LCD_CEPin Port . Pin

Assigns the Port and Pin that the graphic LCD's CE line will attach to.

There is no default setting for this **Declare** and it must be used within the BASIC program.

Declare LCD_CDPin Port . Pin

Assigns the Port and Pin that the graphic LCD's CD line will attach to.

There is no default setting for this **Declare** and it must be used within the BASIC program.

Declare LCD_RSTPin Port . Pin

Assigns the Port and Pin that the graphic LCD's RST line will attach to.

The LCD's RST (Reset) **Declare** is optional and if omitted from the BASIC code, the compiler will not manipulate it. However, if not used as part of the interface, you must set the LCD's RST pin high for normal operation.

Declare LCD_X_Res 0 to 255

LCD displays using the T6963 chipset come in varied screen sizes (resolutions). The compiler must know how many horizontal pixels the display consists of before it can build its library sub-routines.

There is no default setting for this **Declare** and it must be used within the BASIC program.

Declare LCD_Y_Res 0 to 255

LCD displays using the T6963 chipset come in varied screen sizes (resolutions). The compiler must know how many vertical pixels the display consists of before it can build its library subroutines.

There is no default setting for this **Declare** and it must be used within the BASIC program.

Declare LCD_Font_Width 6 or 8

The Toshiba T6963 graphic LCDs have two internal font sizes, 6 pixels wide by eight high, or 8 pixels wide by 8 high. The particular font size is chosen by the LCD's FS pin. Leaving the FS pin floating or bringing it high will choose the 6 pixel font, while pulling the FS pin low will choose the 8 pixel font. The compiler must know what size font is required so that it can calculate screen and RAM boundaries.

Note that the compiler does not control the FS pin and it is down to the circuit layout whether or not it is pulled high or low. There is no default setting for this **Declare** and it must be used within the BASIC program.

Declare LCD_RAM_Size 1024 to 65535

Toshiba graphic LCDs contain internal RAM used for Text, Graphic or Character Generation. The amount of RAM is usually dictated by the display's resolution. The larger the display, the more RAM is normally present. Standard displays with a resolution of 128x64 typically contain 4096 bytes of RAM, while larger types such as 240x64 or 190x128 typically contain 8192 bytes or RAM. The display's datasheet will inform you of the amount of RAM present.

There is no default setting for this **Declare** and it must be used within the BASIC program.

Declare LCD_Text_Pages 1 to n

As mentioned above, Toshiba graphic LCDs contain RAM that is set aside for text, graphics or characters generation. In normal use, only one page of text is all that is required, however, the compiler can re-arrange its library subroutines to allow several pages of text that is continuous. The amount of pages obtainable is directly proportional to the RAM available within the LCD itself. Larger displays require more RAM per page, therefore always limit the amount of pages to only the amount actually required or unexpected results may be observed as text, graphic and character generator RAM areas merge.

This **Declare** is purely optional and is usually not required. There is no default setting for this **Declare**.

Declare LCD_Text_Home_Address 0 to n

The RAM within a Toshiba graphic LCD is split into three distinct uses, text, graphics and character generation. Each area of RAM must not overlap or corruption will appear on the display as one uses the other's assigned space. The compiler's library subroutines calculate each area of RAM based upon where the text RAM starts. Normally the text RAM starts at address 0, however, there may be occasions when it needs to be set a little higher in RAM. The order of RAM is; Text, Graphic, then Character Generation.

This **Declare** is purely optional and is usually not required. There is no default setting for this **Declare**.

The diagram below shows a typical circuit for an interface with a Toshiba T6963 graphic LCD.

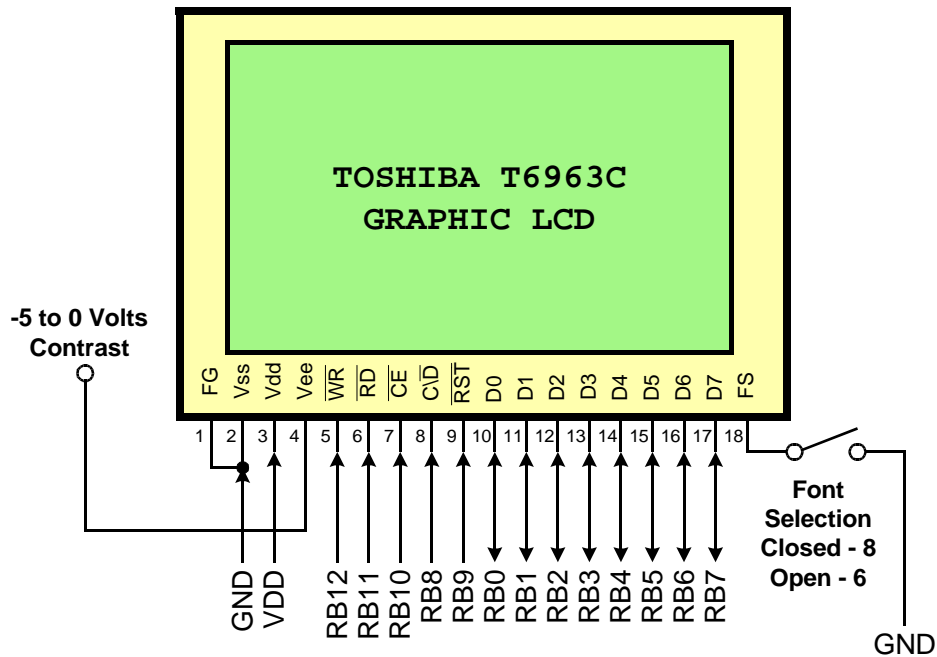

Example

```

' Toshiba T6963C graphic LCD demo
  Device = 24FJ64GA002
  Declare Xtal = 16
' Toshiba T6963C graphic LCD Pin configuration
  Declare LCD_Type = Toshiba           ' LCD's type is Toshiba T6963C
  Declare LCD_DTPort = PORTB.Byte0     ' The LCD's 8-bit Data port
  Declare LCD_WRPin = PORTB.12         ' The LCD's WR pin
  Declare LCD_RDPin = PORTB.11        ' The LCD's RD pin
  Declare LCD_CEPin = PORTB.10        ' The LCD's CE pin
  Declare LCD_CDPin = PORTB.8         ' The LCD's CD pin
  Declare LCD_RSTPin = PORTB.9        ' The LCD's RST pin (optional)
'
' Toshiba T6963C graphic LCD setup configuration
'
  Declare LCD_Font_Width = 8           ' The font width ( 6 or 8 )
  Declare LCD_X_Res = 128             ' The X resolution of the LCD
  Declare LCD_Y_Res = 64              ' The Y resolution of the LCD
  Declare LCD_Text_Home_Address = 0    ' The home address of the LCD
  Declare LCD_RAM_Size = 8192         ' The amount of RAM the LCD contains
  Declare LCD_Text_Pages = 1          ' The amount of text pages required

  Include "T6963C.inc"               ' Load the Toshiba T6963C routines into the program
'
' Create variables used in the demo
'
  Dim MyCodeString As Code = "From Code",0
  Dim MyRAMString As String * 20 = "From RAM"
  Dim MyWord As Word = 1234
  Dim MyDword As Dword = 12345
  Dim MyFloat As Float = 3.14

  Cls                                ' Clear Text and Graphic RAM
  Print At 1,0, "1234567890ABCDEF"
  Print At 2,0, Dec MyWord
  Print At 3,0, Dec MyDword
  Print At 4,0, Dec MyFloat
  Print At 5,0, MyRAMString
  Print At 6,0, MyCodeString
  
```

Using an ILI9320 320x240 pixel Colour Graphic LCD

Once a colour graphic LCD has been chosen using the **Declare LCD_Type** directive, all **Print** outputs will be directed to that LCD.

The standard modifiers used by an alphanumeric LCD may also be used with the graphics LCD. Most of the previous modifiers still work in the expected manner, however, the **At** modifier now starts at Ypos 0 and Xpos 0, where values 0,0 will be the top left corner of the LCD. And each cursor position is pixel based. The **Inverse**, **Xor**, and **Or** modifiers are not available for a colour LCD.

There are two new modifiers specifically for a colour LCD. These are: -

Ink 0 to 65535 Choose the colour of the pixel used for a character
Paper 0 to 65535 Choose the colour of the background under a character

Once one of the new modifiers has been enabled, all future **Print** commands will use that particular feature until the modifier is altered, or the Ink or Paper colour is chosen by the **GLCD_Ink** or **GLCD_Paper** commands. For example: -

```
' Enable red characters from this point
Print At 0, 0, Ink cBrightRed, "Hello World"
Print At 30, 0, "Still Red"
' Now use black characters
Print At 60, 0, Ink cBlack, "Black Characters"
```

If no modifiers are present, then the character's ASCII representation will be displayed: -

```
' Print characters A and B
Print At 0, 0, 65, 66
```

The routines for the ILI9320 colour graphic LCD must be included into the program before they are used, and the declares, listed later, must be placed. The LCD routines themselves are written in Proton24 BASIC so their operation may be readily changed.

Example.

```
' Demonstrate the Print command with an ILI9320 colour graphic LCD
,
Device = 24EP128MC202
Declare Xtal = 140.03
,
' Setup the Pins used by the ILI9320 graphic LCD
,
Declare LCD_DTPort = PORTB.Byte0 ' Use the first 8-bits of PORTB
Declare LCD_CSPin = PORTB.8 ' Connect to the LCD's CS pin
Declare LCD_RDPin = PORTB.9 ' Connect to the LCD's RD pin
Declare LCD_RSPin = PORTB.10 ' Connect to the LCD's RS pin
Declare LCD_WRPin = PORTA.3 ' Connect to the LCD's WR pin

Include "ILI9320.inc" ' Load the ILI9320 routines into the program
-----
```

Main:

```
' Configure the internal oscillator to operate the device at 140.03MHz
PLL_Setup(76, 2, 2, $0300)

Cls clWhite ' Clear the LCD with the colour white
```

```
Glcd_SetFont(CourierNew_20)      ' Choose the font to use
Print At 0,0, Ink clBrightBlue, "Hello World"

-----
' Load the font required
  Include "CourierNew_20.inc"
,
' Configure for internal 7.37MHz oscillator with PLL
' OSC pins are general purpose I/O
,
  Config FGS = GWRP_OFF, GCP_OFF
  Config FOSCSEL = FNOSC_FRCPLL, IESO_ON, PWMLOCK_OFF
  Config FOSC = POSCMD_NONE, OSCIOFNC_ON, IOL1WAY_OFF, FCKSM_CSDCMD
  Config FWDT = WDTPOST_PS256, WINDIS_OFF, PLLKEN_ON, FWDTEN_OFF
  Config FPOR = ALTI2C1_ON, ALTI2C2_OFF
  Config FICD = ICS_PGD1, JTAGEN_OFF
```

Fonts can be created using the supplied program named *FontCreator.exe*, and can be found in the IDE's *plugins* folder.

With an ILI9320 320x240 pixel colour graphic LCD, the colour is a 16-bit value formatted in RGB565, where the upper 5-bits represent the red content, the middle 6-bits represent the green content, and the lower 5-bits represent the blue content. As illustrated below:

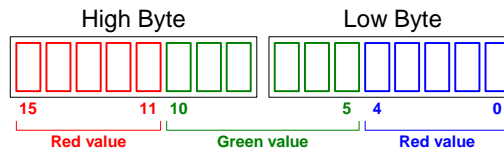

For convenience, there are several colours defined within the ILI9320.inc file. These are:

```
clBlack
clBrightBlue
clBrightGreen
clBrightCyan
clBrightRed
clBrightMagenta
clBrightYellow
clBlue
clGreen
clCyan
clRed
clMagenta
clBrown
clLightGray
clDarkGray
clLightBlue
clLightGreen
clLightCyan
clLightRed
clLightMagenta
clYellow
clWhite
```

More constant values for colours can be added by the user if required.

A suitable circuit for the Ampire AM240320D4T0QWT00H(R) module is shown below:

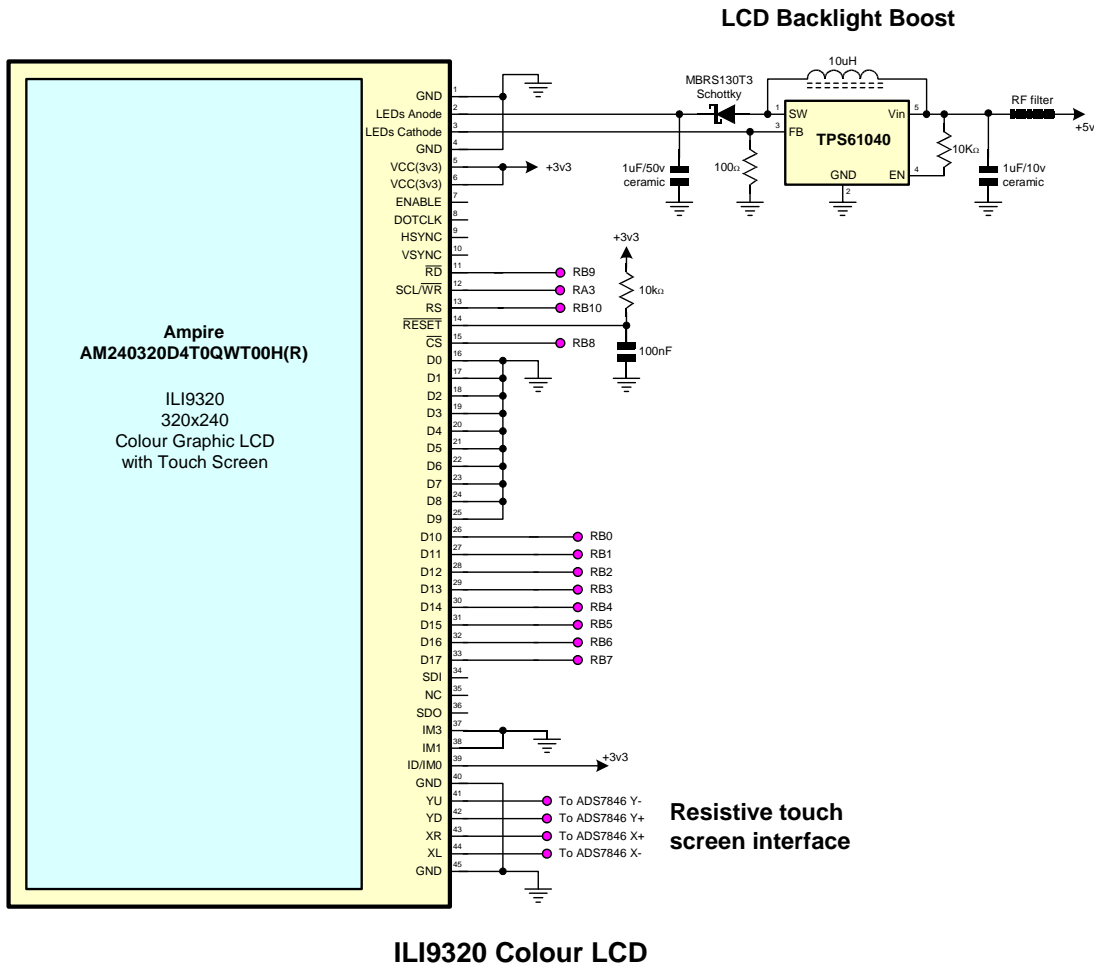

ILI9320 colour graphic LCD Declares

There are several declares associated with an ILI9320 colour graphic LCD.

Declare **LCD_DTPort** Port

Assign the port that will output the 8-bit data to the graphic LCD.

There is no default setting for this **Declare** and it must be used within the BASIC program.

Declare **LCD_WRPin** Port . Pin

Assigns the Port and Pin that the graphic LCD's WR line will attach to.

There is no default setting for this **Declare** and it must be used within the BASIC program.

Declare **LCD_RDPin** Port . Pin

Assigns the Port and Pin that the graphic LCD's RD line will attach to.

There is no default setting for this **Declare** and it must be used within the BASIC program.

Declare **LCD_CSPin** Port . Pin

Assigns the Port and Pin that the graphic LCD's CS line will attach to.

There is no default setting for this **Declare** and it must be used within the BASIC program.

Declare LCD_RSPort . Pin

Assigns the Port and Pins that the graphic LCD's RS line will attach to.

There is no default setting for this **Declare** and it must be used within the BASIC program.

Declare LCD_RSTPort . Pin

Assigns the Port and Pin that the graphic LCD's RST line will attach to.

The LCD's RST (Reset) **Declare** is optional and if omitted from the BASIC code the compiler will not manipulate it. However, if not used as part of the interface, you must set the LCD's RST pin high for normal operation.

Note.

The ILI9320 graphic LCD is a “non-intelligent” type, therefore, a separate character set is required. This is held internally in code memory and is chosen by issuing the **Glcd_SetFont**(pFont) command.

Ptr8, Ptr16, Ptr32, Ptr64

Syntax

Assignment Variable = **Ptr8** (Address)

Assignment Variable = **Ptr16** (Address)

Assignment Variable = **Ptr32** (Address)

Assignment Variable = **Ptr64** (Address)

or

Ptr8 (Address) = Variable

Ptr16 (Address) = Variable

Ptr32 (Address) = Variable

Ptr64 (Address) = Variable

Overview

Indirectly address RAM for loading or retrieving using a variable to hold the 16-bit address.

Parameters

Variable is a user defined variable that holds the result of the indirectly address RAM area, or the variable to place into the indirectly addressed RAM area.

Address is a **Word** variable that holds the 16-bit address of the RAM area of interest.

Address can also post or pre increment or decrement:

- (MyAddress++) Post increment MyAddress after retrieving its RAM location.
- (MyAddress --) Post decrement MyAddress after retrieving its RAM location.
- (++MyAddress) Pre increment MyAddress before retrieving its RAM location.
- (--MyAddress) Pre decrement MyAddress before retrieving its RAM location.

Ptr8 will load or retrieve a value with an optional 8-bit post or pre increment or decrement.

Ptr16 will load or retrieve a value with an optional 16-bit post or pre increment or decrement.

Ptr32 will load or retrieve a value with an optional 32-bit post or pre increment or decrement.

Ptr64 will load or retrieve a value with an optional 64-bit post or pre increment or decrement.

8-bit Example.

```
'  
' Load and Read 8-bit values indirectly from/to RAM  
'  
Device = 24FJ64GA002  
Declare Xtal = 16  
Declare Hserial_Baud = 9600 ' UART1 baud rate  
Declare Hrsout1_Pin = PORTB.14 ' Select pin to be used for TX  
  
Dim MyByteArray[20] As Byte ' Create a byte array  
Dim MyByte As Byte ' Create a byte variable  
Dim bIndex As Byte  
Dim wAddress as Word ' Create a variable to hold address
```

```
Main:
  RPOR7 = 3          ' Make PPS Pin RP14 U1TX
,
' Load into RAM
,
  wAddress = AddressOf(MyByteArray) ' Load wAddress with address of array
  For bIndex = 19 To 0 Step -1      ' Create a loop
    Ptr8(wAddress++) = bIndex      ' Load RAM with address post increment
  Next
,
' Read from RAM
,
  wAddress = AddressOf(MyByteArray) ' Load wAddress with address of array
  Do                                ' Create a loop
    MyByte = Ptr8(wAddress++)      ' Retrieve from RAM with post increment
    HRSOut Dec MyByte, 13          ' Transmit the byte read from RAM
    If MyByte = 0 Then Break      ' Exit when a null(0) is read from RAM
  Loop
```

16-bit Example.

```
' Load and Read 16-bit values indirectly from/to RAM
,
  Device = 24FJ64GA002
  Declare Xtal = 16
  Declare Hserial_Baud = 9600      ' UART1 baud rate
  Declare Hrsout1_Pin = PORTB.14  ' Select pin is to be used for TX

  Dim MyWordArray[20] As Word     ' Create a word array
  Dim MyWord As Word              ' Create a word variable
  Dim bIndex As Byte
  Dim wAddress as Word           ' Create a variable to hold the address

Main:
  RPOR7 = 3          ' Make PPS Pin RP14 U1TX
,
' Load into RAM
,
  wAddress = AddressOf(MyWordArray) ' Load wAddress with address of array
  For bIndex = 19 To 0 Step -1      ' Create a loop
    Ptr16(wAddress++) = bIndex      ' Load RAM with address post increment
  Next
,
' Read from RAM
,
  wAddress = AddressOf(MyWordArray) ' Load wAddress with address of array
  Do                                ' Create a loop
    MyWord = Ptr16(wAddress++)      ' Retrieve from RAM with post increment
    HRSOut Dec MyWord, 13          ' Transmit the word read from RAM
    If MyWord = 0 Then Break      ' Exit when a null(0) is read from RAM
  Loop
```

32-bit Example.

```
' Load and Read 32-bit values indirectly from RAM
',
Device = 24FJ64GA002
Declare Xtal = 16
Declare Hserial_Baud = 9600           ' UART1 baud rate
Declare Hrsout1_Pin = PORTB.14       ' Select pin is to be used for TX

Dim MyDwordArray[20] As Dword        ' Create a dword array
Dim MyDword As Dword                 ' Create a dword variable
Dim bIndex As Byte
Dim wAddress as Word                 ' Create a variable to hold the address

Main:
  RPOR7 = 3                           ' Make PPS Pin RP14 U1TX
',
' Load into RAM
',
wAddress = AddressOf(MyDwordArray)    ' Load wAddress with address of array
For bIndex = 19 To 0 Step -1          ' Create a loop
  Ptr32(wAddress++) = bIndex          ' Load RAM with address post increment
Next
',
' Read from RAM
',
wAddress = AddressOf(MyDwordArray)    ' Load wAddress with address of array
Do                                    ' Create a loop
  MyDword = Ptr32(wAddress++)         ' Retrieve from RAM with post increment
  HRSOut Dec MyDword, 13              ' Transmit the dword read from RAM
  If MyDword = 0 Then Break          ' Exit when a null(0) is read from RAM
Loop
```

See also: [AddressOf](#), [cPtr8](#), [cPtr16](#), [cPtr32](#), [cPtr64](#).

PulseIn

Syntax

Assignment Variable = **PulseIn** *Pin*, *State*

Overview

Change the specified pin to input and measure an input pulse.

Parameters

Assignment Variable is a user defined variable. This may be a word variable with a range of 1 to 65535, or a byte variable with a range of 1 to 255.

Pin is a Port.Pin constant that specifies the I/O pin to use.

State is a constant (0 or 1) or name **High** - **Low** that specifies which edge must occur before beginning the measurement.

Example

```
Device = 24HJ128GP502
Declare Xtal = 16
Declare Hserial_Baud = 9600           ' UART1 baud rate
Declare Hrsout1_Pin = PORTB.14       ' Select pin is to be used for TX

Dim Var1 as Byte

RPOR7 = 3                             ' Make PPS Pin RP14 U1TX

Do
  Var1 = PulseIn PORTB.0, 1           ' Measure a pulse on pin 0 of PORTB.
  HrsoutLn Dec Var1                   ' Display the reading
  DelayMs 500                          ' Repeat the process
Loop
```

Notes.

PulseIn acts as a fast clock that is triggered by a change in state (0 or 1) on the specified pin. When the state on the pin changes to the state specified, the clock starts counting. When the state on the pin changes again, the clock stops. If the state of the pin doesn't change (even if it is already in the state specified in the **PulseIn** instruction), the clock won't trigger. **PulseIn** waits a maximum of 0.65535 seconds for a trigger, then returns with 0 in *variable*.

The variable can be either a **Word** or a **Byte** . If the variable is a word, the value returned by **PulseIn** can range from 1 to 65535 units.

The units are dependant on the frequency of the crystal used. If a 4MHz crystal is used, then each unit is 10us, while a 20MHz crystal produces a unit length of 2us.

If the variable is a byte and the crystal is 4MHz, the value returned can range from 1 to 255 units of 10µs. Internally, **PulseIn** always uses a 16-bit timer. When your program specifies a byte, **PulseIn** stores the lower 8 bits of the internal counter into it. Pulse widths longer than 2550µs will give false, low readings with a byte variable. For example, a 2560µs pulse returns a reading of 256 with a word variable and 0 with a byte variable.

See also : Counter, PulseOut, RCin.

PulseOut

Syntax

PulseOut *Pin*, *Period*, { *Initial State* }

Overview

Generate a pulse on *Pin* of specified *Period*. The pulse is generated by toggling the pin twice, thus the initial state of the pin determines the polarity of the pulse. Or alternatively, the initial state may be set by using High-Low or 1-0 after the *Period*. *Pin* is automatically made an output.

Parameters

Pin is a Port.Pin constant that specifies the I/O pin to use.

Period can be a constant of user defined variable. See notes.

State is an optional constant (0 or 1) or name **High - Low** that specifies the state of the outgoing pulse.

Example

```
' Send a high pulse 1ms long to PORTB.5
',
Device = 24HJ128GP502
Declare Xtal = 16

Low PORTB.5
PulseOut PORTB.5, 100
',
' Send a high pulse 1ms long to PORTB.5
',
PulseOut PORTB.5, 100, High
```

See also : Counter , PulseIn, RCin.

Push

Syntax

Push *Variable*, {*Variable*, *Variable* etc}

Overview

Place a single variable or multiple variables onto the microcontroller's stack.

Parameters

Variable is a user defined variable of type **Bit**, **Byte**, **Word**, **Dword**, **Float**, **Double**, **Arrays**, **String**, or **constant** value.

The amount of bytes pushed on to the stack varies with the variable type used. The list below shows how many bytes are pushed for a particular variable type, and their order. The microcontroller's stack is word orientated, therefore all operations are accomplished using 16-bits.

Bit	2 Bytes are pushed that hold the condition of the bit.
Byte	2 Bytes are pushed.
Byte Array	2 Bytes are pushed.
Word	2 Bytes are pushed. High Byte then Low Byte.
Word Array	2 Bytes are pushed. High Byte then Low Byte.
Dword Array	4 Bytes are pushed. High Byte, Mid2 Byte, Mid1 Byte then Low Byte.
Float Array	4 Bytes are pushed. High Byte, Mid2 Byte, Mid1 Byte then Low Byte.
Dword	4 Bytes are pushed. High Byte, Mid2 Byte, Mid1 Byte then Low Byte.
Float	4 Bytes are pushed. High Byte, Mid2 Byte, Mid1 Byte then Low Byte.
Double	8 Bytes are pushed. High Byte, Midx Bytes, then Low Byte.
String	2 Bytes are pushed. High Byte then Low Byte that point to the start address of the string in memory.
Constant	Amount of bytes varies according to the value pushed. High Byte first.

Example 1

' Push two variables on to the stack then retrieve them

```
Device = 24HJ128GP502
Declare Xtal = 16
Declare Stack_Size = 90      ' Increase the stack for holding extra words

Dim MyWord as Word          ' Create a Word variable
Dim MyDword as Dword       ' Create a Dword variable

MyWord = 1234               ' Load the Word variable with a value
MyDword = 567890           ' Load the Dword variable with a value
Push MyWord, MyDword       ' Push the Word variable then the Dword variable

Clear MyWord                ' Clear the Word variable
Clear MyDword               ' Clear the Dword variable

Pop MyDword, MyWord         ' Pop the Dword variable then the Word variable
Print Dec MyWord, " ", Dec MyDword ' Display the variables as decimal
```

Example 2

```
' Push a String on to the stack then retrieve it

Device = 24HJ128GP502
Declare Xtal = 16
Declare Stack_Size = 80          ' Increase the stack for holding extra words

Dim SourceString as String * 20 ' Create a String variable
Dim DestString as String * 20   ' Create another String variable

SourceString = "Hello World"    ' Load the String variable with characters

Push SourceString                ' Push the String variable's address

Pop DestString                   ' Pop the previously pushed String into DestString
Print DestString                 ' Display the string, which will be "Hello World"
```

Formatting a Push.

Each variable type, and more so, constant value, will push a different amount of bytes on to the stack. This can be a problem where values are concerned because it will not be known what size variable is required in order to **Pop** the required amount of bytes from the stack. For example, the code below will push a constant value of 200 onto the stack, which requires 2 bytes (remember, the stack is 16-bit orientated).

```
Push 200
```

All well and good, but what if the recipient popped variable is of a **Dword** or **Float** type.

```
Pop MyWord
```

Popping from the stack into a **Dword** variable will actually pull 4 bytes from the stack, however, the code above has only pushed two bytes, so the stack will become out of phase with the values or variables previously pushed. This is not really a problem where variables are concerned, as each variable has a known byte count and the user knows if a **Word** is pushed, a **Word** should be popped.

The answer lies in using a formatter preceding the value or variable pushed, that will force the amount of bytes loaded on to the stack. The formatters are **Byte**, **Word**, **Dword** or **Float**.

The **Byte** formatter will force any variable or value following it to push only 1 word to the stack.

```
Push Byte 12345
```

The **Word** formatter will force any variable or value following it to push only 1 word to the stack:

```
Push Word 123
```

The **Dword** formatter will force any variable or value following it to push only 2 words to the stack: -

```
Push Dword 123
```

The **Float** formatter will force any variable or value following it to push only 2 words to the stack, and will convert a constant value into the 2-word floating point format: -

```
Push Float 123.1
```

The **Double** formatter will force any variable or value following it to push only 4 words to the stack, and will convert a constant value into the 4-word 64-bit floating point format: -

```
Push Double 123.1
```

So for the **Push** of 200 code above, you would use: -

```
Push Word 200
```

In order for it to be popped back into a **Word** variable, because the push would be the high byte of 200, then the low byte.

If using the multiple variable **Push**, each parameter can have a different formatter preceding it.

```
Push Word 200, Dword 1234, Float 1234
```

Note that if a floating point value is pushed, 2 words will be placed on the stack because this is a known format.

What is a Stack?

Unlike the 8-bit PIC[®] microcontrollers, the PIC24[®] and dsPIC33[®] devices have a true stack, which is an area of RAM allocated for temporary data storage and call-return address's.

The stack is always present within a PIC24[®] or dsPIC33[®] device and is located at the end of the variable RAM. The microcontroller uses it for call and return addresses, but it can also be used for temporary storage of variables. The stack defaults to 60 words, but can be increased or decreased by issuing the **Stack_Size Declare**.

```
Declare Stack_Size = 200
```

The above line of code will increase the stack to 200 words.

Taking the above line of code as an example, we can examine what happens when a variable is pushed on to the 200 word stack, and then popped off again.

Pushing.

When a **Word** variable is pushed onto the stack, the memory map would look like the diagram below: -

```
End Of Stack   Empty RAM
                ~      ~
                ~      ~
                Empty RAM
Start Of Stack Contents of the Word Variable
```

Because each element of the stack is 16-bit wide, the contents of the **Word** variable are placed directly into it. The stack grows in an upward direction whenever a **Push** is implemented, which means it shrinks back down whenever a **Pop** is implemented.

If we were to **Push** a **Dword** variable on to the stack as well as the **Word** variable, the stack memory would look like: -

```
End Of Stack   Empty RAM
               ~      ~
               ~      ~
               Empty RAM
               Contents of the Word Variable
               Contents of the High Word of the Dword Variable
Start Of Stack Contents of the Low Word of the Dword Variable
```

Popping.

When using the **Pop** command, the same variable type that was pushed last must be popped first, or the stack will become out of phase and any variables that are subsequently popped will contain invalid data, and there is a possibility that the microcontroller will cause an exception.

For example, using the above analogy, we need to **Pop** a **Dword** variable first. The **Dword** variable will be popped Low Word first, then the High Word. This will ensure that the same value pushed will be reconstructed correctly when placed into its recipient variable. After the **Pop**, the stack memory map will look like: -

```
End Of Stack   Empty RAM
               ~      ~
               ~      ~
               Empty RAM
Start Of Stack Contents of the Word Variable
```

If a **Word** variable was then popped, the stack will be empty, unless it already contains call/return address's. Now what if we popped a **Dword** variable instead of the required **Word** variable? the stack would underflow by one word and definitely cause an exception. The same is true if the stack overflows.

Technical Details of Stack implementation.

The stack implemented by the PIC24[®] and dsPIC33[®] microcontroller's is known as an **Incrementing Last-In First-Out** Stack. *Incrementing* because it grows upwards in memory. *Last-In First-Out* because the last variable pushed, will be the first variable popped.

The stack is not circular in operation, so that a stack underflow or overflow will cause an exception to be triggered.

Whenever a variable is popped from the stack, the stack's memory is not actually cleared, only the stack pointer is moved (**WREG15**). Therefore, the above diagrams are not quite true when they show empty RAM, but unless you have use of the remnants of the variable, it should be considered as empty, and will be overwritten by the next **Push** command.

See also : **Pop.**

Pwm

Syntax

Pwm *Pin, Duty, Cycles*

Overview

Output pulse-width-modulation on a pin, then return the pin to input state.

Parameters

Pin is a Port.Pin constant that specifies the I/O pin to use.

Duty is a variable, constant (0-255), or expression, which specifies the analogue level desired (0-5 volts).

Cycles is a variable or constant (0-255) which specifies the number of cycles to output. Larger capacitors require multiple cycles to fully charge. Cycle time is very dependant on the oscillator frequency of the microcontroller. The faster the oscillator, the faster the duty cycle.

Notes.

Pwm can be used to generate analogue voltages (0-3.3V) through a pin connected to a resistor and capacitor to ground; the resistor-capacitor junction is the analogue output (see circuit). Since the capacitor gradually discharges, **Pwm** should be executed periodically to refresh the analogue voltage.

Pwm emits a burst of 1s and 0s whose ratio is proportional to the *duty* value you specify. If *duty* is 0, then the pin is continuously low (0); if *duty* is 255, then the pin is continuously high. For values in between, the proportion is *duty*/255. For example, if *duty* is 100, the ratio of 1s to 0s is $100/255 = 0.392$, approximately 39 percent.

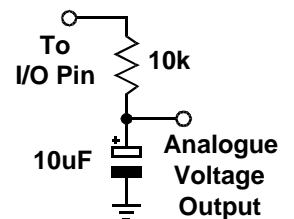

When such a burst is used to charge a capacitor, the voltage across it is equal to:-

$$(\text{duty} / 255) * 3.3.$$

So if *duty* is 100, the capacitor voltage is approximately:

$$(100 / 255) * 3.3 = 1.29 \text{ volts.}$$

See also : **Hpwm, Pulseout, Servo.**

Random

Syntax

Assignment Variable = **Random**

or

Random *Variable*

Overview

Generate a pseudo-randomised value.

Parameters

Assignment Variable is a user defined variable that will hold the pseudo-random value. The pseudo-random algorithm used has a working length of 1 to 65535.

Example

```
Device = 24HJ128GP502  
Declare Xtal = 16
```

```
Var1 = Random           ' Get a random number into Var1  
Random Var1           ' Get a random number into Var1
```

See also: **Seed.**

RCin

Syntax

Assignment Variable = **RCin** Pin, State

Overview

Count time while pin remains in *state*, usually used to measure the charge/ discharge time of resistor/capacitor (RC) circuit.

Parameters

Pin is a Port.Pin constant that specifies the I/O pin to use. This pin will be placed into input mode and left in that state when the instruction finishes.

State is a variable or constant (1 or 0) that will end the Rcin period. Text, High or Low may also be used instead of 1 or 0.

Assignment Variable is a variable in which the time measurement will be stored.

Example

```
Device = 24HJ128GP502
Declare Xtal = 16

Dim MyResult as Word           ' Word variable to hold result.

High PORTB.0                   ' Discharge the cap
DelayMs 1                       ' Wait for 1 ms.
MyResult = RCin PORTB.0, High   ' Measure RC charge time.
Print Dec MyResult, " "         ' Display the value on an LCD.
```

Notes.

The resolution of **RCin** is dependent upon the oscillator frequency. The resolution always changes with the actual oscillator speed. If the pin never changes state 0 is returned.

When **RCin** executes, it starts a counter. The counter stops as soon as the specified pin is no longer in *State* (0 or 1). If *pin* is not in *State* when the instruction executes, **RCin** will return 1 in *Variable*, since the instruction requires one timing cycle to discover this fact. If pin remains in *State* longer than 65535 timing cycles **RCin** returns 0.

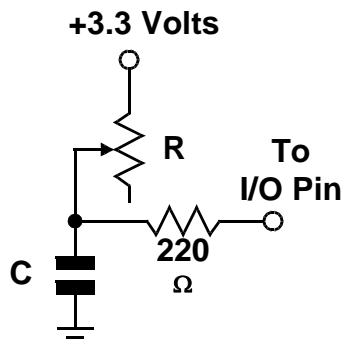

Figure A

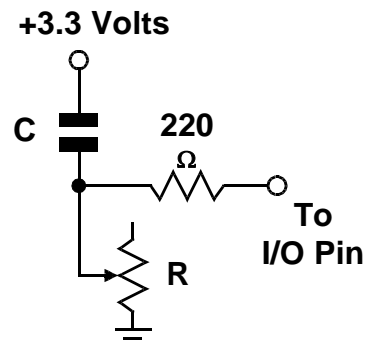

Figure B

The diagrams above show two suitable RC circuits for use with **RCin**. The circuit in figure B is preferred, because of the microcontroller's logic threshold.

Before **RCin** executes, the capacitor must be put into the state specified in the **RCin** command. For example, with figure B, the capacitor must be discharged until both plates (sides of the capacitor) are at 3.3V. It may seem strange that discharging the capacitor makes the input high, but you must remember that a capacitor is charged when there is a voltage difference between its plates. When both sides are at +3.3 Volts, the capacitor is considered discharged. Below is a typical sequence of instructions for the circuit in figure A.

```
Dim MyResult as Word           ' Word variable to hold result.

High PORTB.0                   ' Discharge the cap
DelayMs 1                       ' Wait for 1ms.
MyResult = RCin PORTB.0, High  ' Measure RC charge time.
Print Dec MyResult, " "       ' Display the value on an LCD.
```

See also : Adin, Counter, Pot, Pulseln.

Repeat...Until

Syntax

Repeat *Condition*

Instructions

Instructions

Until *Condition*

or

Repeat { *Instructions* : } **Until** *Condition*

Overview

Execute a block of instructions until a condition is true.

Example

```
Device = 24HJ128GP502
```

```
Declare Xtal = 16
```

```
Dim MyWord as Word
```

```
MyWord = 1
```

```
Repeat
```

```
    Print Dec MyWord, " "
```

```
    DelayMs 200
```

```
    Inc MyWord
```

```
Until MyWord > 10
```

or

```
Repeat High LED : Until PORTA.0 = 1 ' Wait for a Port change
```

Notes.

The **Repeat-Until** loop differs from the **While-Wend** type in that, the **Repeat** loop will carry out the instructions within the loop at least once, then continuously until the condition is true, but the **While** loop only carries out the instructions if the condition is true.

The **Repeat-Until** loop is an ideal replacement to a **For-Next** loop, and actually takes less code space, thus performing the loop faster.

Two commands have been added especially for a **Repeat** loop, these are **Inc** and **Dec**.

Inc. Increment a variable i.e. `MyWord = MyWord + 1`

Dec. Decrement a variable i.e. `MyWord = MyWord - 1`

The above example shows the equivalent to the **For-Next** loop: -

```
For MyWord = 1 to 10 : Next
```

See also : **Do...Loop, While...Wend, For...Next...Step.**

Return

Syntax **Return**

Overview

Return from a subroutine.

See also : **Call, Gosub.**

Right\$

Syntax

Destination String = **Right\$** (*Source String*, *Amount of characters*)

Overview

Extract *n* amount of characters from the right of a source string and copy them into a destination string.

Overview

Destination String can only be a **String** variable, and should be large enough to hold the correct amount of characters extracted from the *Source String*.

Source String can be a **String** variable, or a **Quoted String of Characters**. See below for more variable types that can be used for *Source String*.

Amount of characters can be any valid variable type, expression or constant value, that signifies the amount of characters to extract from the right of the *Source String*. Values start at 1 for the rightmost part of the string and should not exceed 255 which is the maximum allowable length of a String variable.

Example 1

```
' Copy 5 characters from the right of SourceString into DestString
',
Device = 24HJ128GP502
Declare Xtal = 16

Dim SourceString as String * 20 ' Create a String of 20 characters
Dim DestString as String * 20 ' Create another String

SourceString = "Hello World" ' Load the source string with characters
',
' Copy 5 characters from the source string into the destination string
',
DestString = Right$ (SourceString, 5)
Print DestString ' Display the result, which will be "World"
```

Example 2

```
' Copy 5 characters from right of a Quoted Character String to DestString
',
Device = 24HJ128GP502
Declare Xtal = 16

Dim DestString as String * 20 ' Create a String of 20 characters
',
' Copy 5 characters from the quoted string into the destination string
',
DestString = Right$ ("Hello World", 5)
Print DestString ' Display the result, which will be "World"
```

The *Source String* can also be a **Byte**, **Word**, **Dword**, **Float** or **Array**, variable, in which case the value contained within the variable is used as a pointer to the start of the Source String's address in RAM.

Example 3

```
' Copy 5 characters from the right of SourceString into DestString using a
' pointer to SourceString

Device = 24HJ128GP502
Declare Xtal = 16

Dim SourceString as String * 20 ' Create a String of 20 characters
Dim DestString as String * 20 ' Create another String
' Create a Word variable to hold the address of SourceString
Dim StringAddr as Word

SourceString = "Hello World" ' Load the source string with characters
,
' Locate the start address of SourceString in RAM
,
StringAddr = AddressOf(SourceString)
,
' Copy 5 characters from the source string into the destination string
,
DestString = Right$(StringAddr, 5)
Print DestString ' Display the result, which will be "World"
```

A third possibility for *Source String* is a Label name, in which case a null terminated Quoted String of Characters is read from code memory.

Example 4

```
' Copy 5 characters from the right of a code memory string into DestString
,
Device = 24HJ128GP502
Declare Xtal = 16

Dim DestString as String * 20 ' Create a String of 20 characters
,
' Create a null terminated string of characters in code memory
,
Dim Source as Code = "Hello World", 0
,
' Copy 5 characters from label Source into the destination string
,
DestString = Right$(Source, 5)
Print DestString ' Display the result, which will be "World"
```

See also : **Creating and using Strings, Creating and using code memory strings, Len, Left\$, Mid\$, Str\$, ToLower, ToUpper, AddressOf.**

Rol

Syntax

Rol Variable {,Set or Clear}

Overview

Bitwise rotate a variable left with or without the microcontroller's Carry flag.

Parameters

Variable may be any standard variable type, but not an array.

Set or **Clear** are optional parameters that will clear or set the Carry flag before the rotate.

If no parameter is placed after the Variable, the current Carry flag state will be rotated into the LSB (Least Significant Bit) of variable.

Example.

```
' Demonstrate the Rol Command
,
Device = 24FJ64GA002
Declare Xtal = 32
Declare Hserial_Baud = 9600           ' UART1 baud rate
Declare Hrsout1_Pin = PORTB.14      ' Select the pin for TX with USART1

Dim Index As Byte
Dim MyByte As Byte
Dim Byteout As Byte

RPOR7 = 3                            ' Make Pin RP14 U1TX
,
' Rotate the carry through MyByte
,
MyByte = %10000000
Rol MyByte
Rol MyByte
Rol MyByte
Rol MyByte
Rol MyByte
Rol MyByte
Rol MyByte
Rol MyByte
Rol MyByte
,
' Set each bit of MyByte with every rotate
,
MyByte = %00000000
For Index = 0 To 7
    Rol MyByte, Set
    HRSOutLn Bin8 MyByte
Next
HRSOutLn "-----"
,
' Clear each bit of MyByte with every rotate
,
MyByte = %11111111
For Index = 0 To 7
    Rol MyByte, Clear
    HRSOutLn Bin8 MyByte
Next
HRSOutLn "-----"
```

```
,  
' Transfer the value of MyByte to Byteout, but reversed  
,  
MyByte = %10000000  
Byteout = %00000000  
For Index = 0 To 7  
    Rol MyByte  
    Ror Byteout  
    HRSOutLn Bin8 Byteout  
Next  
,  
' Configure for internal 8MHz oscillator with PLL  
' OSC pins are general purpose I/O  
,  
Config Config1 = JTAGEN_OFF, GCP_OFF, GWRP_OFF, BKBUG_OFF, _  
    COE_OFF, ICS_PGx1, FWDTEN_OFF, WINDIS_OFF, _  
    FWPSA_PR128, WDTPOST_PS256  
Config Config2 = IOL1WAY_OFF, COE_OFF, IESO_OFF, FNOSC_FRCPLL, _  
    FCKSM_CSDCMD, OSCIOFNC_ON, POSCMOD_NONE
```

See also: **Ror.**

Ror

Syntax

Ror *Variable* {, *Set* or *Clear*}

Overview

Bitwise rotate a variable right with or without the microcontroller's Carry flag.

Parameters

Variable may be any standard variable type, but not an array.

Set or **Clear** are optional parameters that will clear or set the Carry flag before the rotate.

If no parameter is placed after the *Variable*, the current Carry flag state will be rotated into the MSB (Most Significant Bit) of variable.

Example.

```
' Demonstrate the Ror Command
,
Device = 24FJ64GA002
Declare Xtal = 32
Declare Hserial_Baud = 9600           ' UART1 baud rate
Declare Hrsout1_Pin = PORTB.14      ' Select the pin for TX with USART1

Dim Index As Byte
Dim MyByte As Byte
Dim Byteout As Byte

RPOR7 = 3                            ' Make Pin RP14 U1TX
,
' Rotate the carry through MyByte
,
MyByte = %00000001
Ror MyByte
Ror MyByte
Ror MyByte
Ror MyByte
Ror MyByte
Ror MyByte
Ror MyByte
Ror MyByte
Ror MyByte
,
' Set each bit of MyByte with every rotate
,
MyByte = %00000000
For Index = 0 To 7
    Ror MyByte, Set
    HRSOutLn Bin8 MyByte
Next
HRSOutLn "-----"
,
' Clear each bit of MyByte with every rotate
,
MyByte = %11111111
For Index = 0 To 7
    Ror MyByte, Clear
    HRSOutLn Bin8 MyByte
Next
HRSOutLn "-----"
```

```
,  
' Transfer the value of MyByte to Byteout, but reversed  
,  
MyByte = %00000001  
Byteout = %00000000  
For Index = 0 To 7  
    Ror MyByte  
    Rol Byteout  
    HRSOutLn Bin8 Byteout  
Next  
,  
' Configure for internal 8MHz oscillator with PLL  
' OSC pins are general purpose I/O  
,  
Config Config1 = JTAGEN_OFF, GCP_OFF, GWRP_OFF, BKBUG_OFF, _  
    COE_OFF, ICS_PGx1, FWDTEN_OFF, WINDIS_OFF, _  
    FWPSA_PR128, WDTPOST_PS256  
Config Config2 = IOL1WAY_OFF, COE_OFF, IESO_OFF, FNOSC_FRCPLL, _  
    FCKSM_CSDCMD, OSCIOFNC_ON, POSCMOD_NONE
```

See also: **Rol.**

Rsin

Syntax

Assignment Variable = **Rsin**, { *Timeout Label* }

or

Rsin { *Timeout Label* }, *Modifier..Variable* {, *Modifier.. Variable...*}

Overview

Receive one or more bytes from a predetermined pin at a predetermined baud rate in standard asynchronous format using 8 data bits, no parity and 1 stop bit (8N1). The pin is automatically made an input.

Parameters

Modifiers may be one of the serial data modifiers explained below.

Assignment Variable can be any user defined variable.

An optional *Timeout Label* may be included to allow the program to continue if a character is not received within a certain amount of time. *Timeout* is specified in units of 1 millisecond and is specified by using a **Declare** directive.

Example

```
Device = 24HJ128GP502
Declare Xtal = 16
Declare Rsin_Timeout = 2000      ' Timeout after 2 seconds

Dim MyByte as Byte
Dim MyWord as Word
MyByte = Rsin, {Label}
Rsin MyByte, MyWord
Rsin { Label }, MyByte, MyWord
```

Label: { do something when timed out }

Declares

There are four **Declares** for use with **Rsin**. These are :-

Declare Rsin_Pin Port . Pin

Assigns the Port and Pin that will be used to input serial data by the **Rsin** command. This may be any valid port on the microcontroller.

If the **Declare** is not used in the program, then the default Port and Pin is PORTB.1.

Declare Rsin_Mode Inverted, True or 1, 0

Sets the serial mode for the data received by **Rsin**. This may be inverted or true. Alternatively, a value of 1 may be substituted to represent inverted, and 0 for true.

If the **Declare** is not used in the program, then the default mode is Inverted.

Declare Serial_Baud 0 to 65535 bps (baud)

Informs the **Rsin** and **Rsout** routines as to what baud rate to receive and transmit data.

Virtually any baud rate may be transmitted and received, but there are standard bauds: -

300, 600, 1200, 2400, 4800, 9600, and 19200.

When using a 4MHz crystal, the highest baud rate that is reliably achievable is 9600. However, an increase in the oscillator speed allows higher baud rates to be achieved, including 38400 baud.

If the **Declare** is not used in the program, then the default baud is 9600.

Declare Rsin_Timeout 0 to 65535 milliseconds (ms)

Sets the time, in milliseconds, that **Rsin** will wait for a start bit to occur.

Rsin waits in a tight loop for the presence of a start bit. If no timeout value is used, then it will wait forever. The **Rsin** command has the option of jumping out of the loop if no start bit is detected within the time allocated by timeout.

If the **Declare** is not used in the program, then the default timeout value is 10000ms or 10 seconds.

Rsin Modifiers.

As we already know, **Rsin** will wait for and receive a single byte of data, and store it in a variable. If the microcontroller was connected to a PC running a terminal program and the user pressed the "A" key on the keyboard, after the **Rsin** command executed, the variable would contain 65, which is the ASCII code for the letter "A"

What would happen if the user pressed the "1" key? The result would be that the variable would contain the value 49 (the ASCII code for the character "1"). This is an important point to remember: every time you press a character on the keyboard, the computer receives the ASCII value of that character. It is up to the receiving side to interpret the values as necessary. In this case, perhaps we actually wanted the variable to end up with the value 1, rather than the ASCII code 49.

The **Rsin** command provides a modifier, called the decimal modifier, which will interpret this for us. Look at the following code: -

```
Dim SerData as Byte
Rsin Dec SerData
```

Notice the decimal modifier in the **Rsin** command that appears just to the left of the SerData variable. This tells **Rsin** to convert incoming text representing decimal numbers into true decimal form and store the result in SerData. If the user running the terminal software pressed the "1", "2" and then "3" keys followed by a space or other non-numeric text, the value 123 will be stored in the variable SerData, allowing the rest of the program to perform any numeric operation on the variable.

Without the decimal modifier, however, you would have been forced to receive each character ("1", "2" and "3") separately, and then would still have to do some manual conversion to arrive at the number 123 (one hundred twenty three) before you can do the desired calculations on it.

The decimal modifier is designed to seek out text that represents decimal numbers. The characters that represent decimal numbers are the characters "0" through "9". Once the **Rsin** command is asked to use the decimal modifier for a particular variable, it monitors the incoming serial data, looking for the first decimal character. Once it finds the first decimal character, it will continue looking for more (accumulating the entire multi-digit number) until it finds a non-decimal numeric character. Remember that it will not finish until it finds at least one decimal character followed by at least one non-decimal character.

To illustrate this further, examine the following examples (assuming we're using the same code example as above): -

Serial input: "ABC"

Result: The program halts at the **Rsin** command, continuously waiting for decimal text.

Serial input: "123" (with no characters following it)

Result: The program halts at the **Rsin** command. It recognises the characters "1", "2" and "3" as the number one hundred twenty three, but since no characters follow the "3", it waits continuously, since there's no way to tell whether 123 is the entire number or not.

Serial input: "123" (followed by a space character)

Result: Similar to the above example, except once the space character is received, the program knows the entire number is 123, and stores this value in SerData. The **Rsin** command then ends, allowing the next line of code to run.

Serial input: "123A"

Result: Same as the example above. The "A" character, just like the space character, is the first non-decimal text after the number 123, indicating to the program that it has received the entire number.

Serial input: "ABCD123EFGH"

Result: Similar to examples 3 and 4 above. The characters "ABCD" are ignored (since they're not decimal text), the characters "123" are evaluated to be the number 123 and the following character, "E", indicates to the program that it has received the entire number.

The final result of the **Dec** modifier is limited to 16 bits (up to the value 65535). If a value larger than this is received by the decimal modifier, the end result will be incorrect because the result rolled-over the maximum 16-bit value. Therefore, **Rsin** modifiers may not (at this time) be used to load **Dword** (32-bit) variables.

The decimal modifier is only one of a family of conversion modifiers available with **Rsin**. See below for a list of available conversion modifiers. All of the conversion modifiers work similar to the decimal modifier (as described above). The modifiers receive bytes of data, waiting for the first byte that falls within the range of characters they accept (e.g., "0" or "1" for binary, "0" to "9" for decimal, "0" to "9" and "A" to "F" for hex). Once they receive a numeric character, they keep accepting input until a non-numeric character arrives, or in the case of the fixed length modifiers, the maximum specified number of digits arrives.

While very effective at filtering and converting input text, the modifiers aren't completely fool-proof. As mentioned before, many conversion modifiers will keep accepting text until the first non-numeric text arrives, even if the resulting value exceeds the size of the variable. After **Rsin**, a **Byte** variable will contain the lowest 8 bits of the value entered and a **Word** (16-bits) would contain the lowest 16 bits. You can control this to some degree by using a modifier that specifies the number of digits, such as **Dec2**, which would accept values only in the range of 0 to 99.

Conversion Modifier	Type of Number	Numeric	Characters Accepted
Dec {1..10}	Decimal, optionally limited to 1 - 10 digits		0 through 9
Hex {1..8}	Hexadecimal, optionally limited to 1 - 8 digits		0 through 9, A through F
Bin {1..32}	Binary, optionally limited to 1 - 32 digits		0, 1

A variable preceded by **Bin** will receive the ASCII representation of its binary value. For example, if **Bin** Var1 is specified and "1000" is received, Var1 will be set to 8.

A variable preceded by **Dec** will receive the ASCII representation of its decimal value. For example, if **Dec** Var1 is specified and "123" is received, Var1 will be set to 123.

A variable preceded by **Hex** will receive the ASCII representation of its hexadecimal value. For example, if **Hex** Var1 is specified and "FE" is received, Var1 will be set to 254.

Skip followed by a count will skip that many characters in the input stream. For example, **Skip** 4 will skip 4 characters.

The **Rsin** command can be configured to wait for a specified sequence of characters before it retrieves any additional input. For example, suppose a device attached to the microcontroller is known to send many different sequences of data, but the only data you wish to observe happens to appear right after the unique characters, "XYZ". A modifier named **Wait** can be used for this purpose: -

```
Rsin Wait("XYZ"), SerData
```

The above code waits for the characters "X", "Y" and "Z" to be received, in that order, then it receives the next data byte and places it into variable SerData.

Str modifier.

The **Rsin** command also has a modifier for handling a string of characters, named **Str**.

The **Str** modifier is used for receiving a string of characters into a byte array variable.

A string is a set of characters that are arranged or accessed in a certain order. The characters "ABC" would be stored in a string with the "A" first, followed by the "B" then followed by the "C". A byte array is a similar concept to a string; it contains data that is arranged in a certain order. Each of the elements in an array is the same size. The string "ABC" would be stored in a byte array containing three bytes (elements).

Below is an example that receives ten bytes and stores them in the 10-byte array, SerString: -

```
Dim SerString[10] as Byte ' Create a 10-byte array.
Rsin Str SerString       ' Fill the array with received data.
Print Str SerString      ' Display the string.
```

If the amount of received characters is not enough to fill the entire array, then a formatter may be placed after the array's name, which will only receive characters until the specified length is reached. For example: -

```
Dim SerString[10] as Byte ' Create a 10-byte array.
Rsin Str SerString\5      ' Fill the first 5-bytes of the array
Print Str SerString\5     ' Display the 5-character string.
```

The example above illustrates how to fill only the first n bytes of an array, and then how to display only the first n bytes of the array. n refers to the value placed after the backslash.

Because of its complexity, serial communication can be rather difficult to work with at times. Using the guidelines below when developing a project using the **Rsin** and **Rsout** commands may help to eliminate some obvious errors: -

Always build your project in steps.

Start with small, manageable pieces of code, (that deal with serial communication) and test them, one individually.

Add more and more small pieces, testing them each time, as you go.

Never write a large portion of code that works with serial communication without testing its smallest workable pieces first.

Pay attention to timing.

Be careful to calculate and overestimate the amount of time, operations should take within the microcontroller for a given oscillator frequency. Misunderstanding the timing constraints is the source of most problems with code that communicate serially. If the serial communication in your project is bi-directional, the above statement is even more critical.

Pay attention to wiring.

Take extra time to study and verify serial communication wiring diagrams. A mistake in wiring can cause strange problems in communication, or no communication at all. Make sure to connect the ground pins (**Vss**) between the devices that are communicating serially.

Verify port setting on the PC and in the Rsin / Rsout commands.

Unmatched settings on the sender and receiver side will cause garbled data transfers or no data transfers. This is never more critical than when a line transceiver is used (i.e. MAX232). Always remember that a line transceiver inverts the serial polarity.

If the serial data received is unreadable, it is most likely caused by a baud rate setting error, or a polarity error.

If receiving data from another device that is not a microcontroller, try to use baud rates of 9600 and below, or alternatively, use a higher frequency crystal.

Because of additional overheads in the microcontroller, and the fact that the **Rsin** command offers no hardware receive buffer for serial communication, received data may sometimes be missed or garbled. If this occurs, try lowering the baud rate, or increasing the crystal frequency. Using simple variables (not arrays) will also increase the chance that the device will receive the data correctly.

Notes.

Rsin is oscillator independent as long as the crystal frequency is declared at the top of the program.

See also : **Declare, Rsout, Serin, Serout, Hrsin, Hrsout, Hserin, Hserout.**

Rsout

Syntax

Rsout *Item* {, *Item*... }

Overview

Send one or more *Items* to a predetermined pin at a predetermined baud rate in standard asynchronous format using 8 data bits, no parity and 1 stop bit (8N1). The pin is automatically made an output.

Parameters

Item may be a constant, variable, expression, or string list.

There are no operands as such, instead there are *modifiers*. For example, if an at sign '@' precedes an *Item*, the ASCII representation for each digit is transmitted.

The modifiers are listed below: -

Modifier	Operation
Bin {1..32}	Send binary digits
Dec {1..10}	Send decimal digits
Hex {1..8}	Send hexadecimal digits
Sbin {1..32}	Send signed binary digits
Sdec {1..10}	Send signed decimal digits
Shex {1..8}	Send signed hexadecimal digits
Ibin {1..32}	Send binary digits with a preceding '%' identifier
Idec {1..10}	Send decimal digits with a preceding '#' identifier
Ihex {1..8}	Send hexadecimal digits with a preceding '\$' identifier
ISbin {1..32}	Send signed binary digits with a preceding '%' identifier
ISdec {1..10}	Send signed decimal digits with a preceding '#' identifier
IShex {1..8}	Send signed hexadecimal digits with a preceding '\$' identifier
Rep c\n	Send character c repeated n times
Str array\n	Send all or part of an array
Cstr Label	Send string data defined in code memory.

The numbers after the **Bin**, **Dec**, and **Hex** modifiers are optional. If they are omitted, then the default is all the digits that make up the value will be displayed.

If a floating point variable is to be displayed, then the digits after the **Dec** modifier determine how many remainder digits are send. i.e. numbers after the decimal point.

```
Dim MyFloat as Float
MyFloat = 3.145
Rsout Dec2 MyFloat      ' Send 2 values after the decimal point
```

The above program will transmit the ASCII representation of the value 3.14

If the digit after the **Dec** modifier is omitted, then 3 values will be displayed after the decimal point.

```
Dim MyFloat as Float
MyFloat = 3.1456
Rsout Dec MyFloat      ' Send 3 values after the decimal point
```

The above program will send 3.145

There is no need to use the **Sdec** modifier for signed floating point values, as the compiler's **Dec** modifier will automatically display a minus result: -

```
Dim MyFloat as Float
MyFloat = -3.1456
Rsout Dec MyFloat      ' Send 3 values after the decimal point
```

The above program will transmit the ASCII representation of the value -3.145

Example

```
Device = 24HJ128GP502
Declare Xtal = 16

Dim Var1 as Byte
Dim MyWord as Word
Dim MyDword as Dword

Rsout "Hello World"           ' Display the text "Hello World"
Rsout "Var1= ", Dec Var1      ' Display the decimal value of Var1
Rsout "Var1= ", Hex Var1     ' Display the hexadecimal value of Var1
Rsout "Var1= ", Bin Var1     ' Display the binary value of Var1
Rsout "MyDword= ", Hex6 MyDword ' Display 6 hex chars of a Dword variable
```

Example 3 will produce the text "\$-1234" on a serial terminal.

The **Cstr** modifier is used in conjunction with code memory strings. The **Dim as Code** directive is used for initially creating the string of characters: -

```
Dim String1 as Code = "Hello World", 0
```

The above line of case will create, in flash memory, the values that make up the ASCII text "Hello World", at address String1. Note the null terminator after the ASCII text.

Null terminated means that a zero (null) is placed at the end of the string of ASCII characters to signal that the string has finished.

To display, or transmit this string of characters, the following command structure could be used:

```
Rsout Cstr String1
```

The label that declared the address where the list of code memory values resided, now becomes the string's name. In a large program with lots of text formatting, this type of structure can save quite literally hundreds of bytes of valuable code space.

Try both these small programs, and you'll see that using **Cstr** saves a few bytes of code: -

First the standard way of displaying text: -

```
Device = 24HJ128GP502
Declare Xtal = 16
Rsout "Hello World\r"
Rsout "How are you?\r"
Rsout "I am fine!\r"
```

Now using the **Cstr** modifier: -

```
Dim Text1 as Code = "Hello World\r", 0
Dim Text2 as Code = "How are you?\r", 0
Dim Text3 as Code = "I am fine!\r", 0

Rsout Cstr Text1
Rsout Cstr Text2
Rsout Cstr Text3
```

Again, note the null terminators after the ASCII text in the code memory data. Without these, the microcontroller will continue to transmit data until a value of 0 is reached.

The **Str** modifier is used for sending a string of bytes from a byte array variable. A string is a set of bytes sized values that are arranged or accessed in a certain order.

The values 1, 2, 3 would be stored in a string with the value 1 first, followed by 2 then followed by the value 3. A byte array is a similar concept to a string; it contains data that is arranged in a certain order. Each of the elements in an array is the same size. The string 1,2,3 would be stored in a byte array containing three bytes (elements).

Below is an example that displays four bytes (from a byte array): -

```
Dim MyArray[10] as Byte ' Create a 10-byte array.
MyArray [0] = "H"       ' Load the first 5 bytes of the array
MyArray [1] = "e"       ' With the data to send
MyArray [2] = "l"
MyArray [3] = "l"
MyArray [4] = "o"
Rsout Str MyArray\5     ' Display a 5-byte string.
```

Note that we use the optional \n argument of **Str**. If we didn't specify this, the microcontroller would try to keep sending characters until all 10 bytes of the array were transmitted. Since we do not wish all 10 bytes to be transmitted, we chose to tell it explicitly to only send the first 5 bytes.

The above example may also be written as: -

```
Dim MyArray[10] as Byte ' Create a 10-byte array.
Str MyArray = "Hello"   ' Load the first 5 bytes of the array
Rsout Str MyArray\5     ' Send 5-byte string.
```

The above example, has exactly the same function as the previous one. The only difference is that the string is now constructed using **Str** as a command instead of a modifier.

Declares

There are four **Declares** for use with **Rsout**. These are : -

Declare Rsout_Pin Port . Pin

Assigns the Port and Pin that will be used to output serial data from the **Rsout** command. This may be any valid port on the device.

Declare Rsout_Mode Inverted, True or 1, 0

Sets the serial mode for the data transmitted by **Rsout**. This may be inverted or true. Alternatively, a value of 1 may be substituted to represent inverted, and 0 for true.

If the **Declare** is not used in the program, then the default mode is Inverted.

Declare Serial_Baud 0 to 65535 bps (Baud)

Informs the **Rsin** and **Rsout** routines as to what baud rate to receive and transmit data.

Virtually any baud rate may be transmitted and received, but there are standard bauds: -

300, 600, 1200, 2400, 4800, 9600, and 19200.

When using a 4MHz crystal, the highest baud rate that is reliably achievable is 9600. However, an increase in the oscillator speed allows higher baud rates to be achieved, including 38400 baud and above.

If the **Declare** is not used in the program, then the default baud is 9600.

Declare Rsout_Pace 0 to 65535 microseconds (us)

Implements a delay between characters transmitted by the **Rsout** command.

On occasion, the characters transmitted serially are in a stream that is too fast for the receiver to catch, this results in missed characters. To alleviate this, a delay may be implemented between each individual character transmitted by **Rsout**.

If the **Declare** is not used in the program, then the default is no delay between characters.

Notes.

Rsout is oscillator independent as long as the crystal frequency is declared at the top of the program.

See also : **Declare, Rsin , Serin, Serout, Hrsin, Hrsout, Hserin, Hserout.**

RsoutLn

Syntax

RsoutLn *Item* {, *Item*... }

Overview

Transmit one or more *Items* to a predetermined pin at a predetermined baud rate in standard asynchronous format using 8 data bits, no parity and 1 stop bit (8N1), and terminate with a Carriage Return(13) or Carriage Return(13) Line Feed(10) or Line Feed(10) Carriage Return(13).. The pin is automatically made an output.

Parameters

Item may be a constant, variable, expression, string list, modifier, or inline command. See the section for **Rsout** for more details.

Declare

There is a declare for the **RsoutLn** command that dictates what values are used as the terminator.

```
Declare Rsout_Terminator = CRLF or LFCR or CR
```

The parameter **CR** will transmit a single value of 13 at the end of transmission.

The parameter **CRLF** will transmit a value of 13 then 10 at the end of transmission.

The parameter **LFCR** will transmit a value of 10 then 13 at the end of transmission.

See also : **Declare, Rsin , Serin, Serout, Hrsin, Hrsout, HrsoutLn, Hserin, Hserout.**

Seed

Syntax

Seed *Value*

Overview

Seed the random number generator, in order to obtain a more random result.

Parameters

Value can be a variable, constant or expression, with a value from 1 to 65535. A value of \$0345 is a good starting point.

Example

```
' Create and display a Random number
Device = 24HJ128GP502
Declare xtal = 16

Dim MyWord as Word

Seed $0345
Cls
While
    MyWord = Random
    Print At 1,1,Dec MyWord, "    "
    DelayMs 500
Wend
```

See also: [Random.](#)

Select..Case..EndSelect

Syntax

Select *Expression*

Case *Condition(s)*
Instructions

{

Case *Condition(s)*
Instructions

Case Else
Statement(s)

}

EndSelect

The curly braces signify optional conditions.

Overview

Evaluate an *Expression* then continually execute a block of BASIC code based upon comparisons to *Condition(s)*. After executing a block of code, the program continues at the line following the **EndSelect**. If no conditions are found to be True and a **Case Else** block is included, the code after the **Case Else** leading to the **EndSelect** will be executed.

Parameters

Expression can be any valid variable, constant, expression or inline command that will be compared to the *Conditions*.

Condition(s) is a statement that can evaluate as True or False. The Condition can be a simple or complex relationship, as described below. Multiple conditions within the same **Case** can be separated by commas.

Instructions can be any valid BASIC command that will be operated on if the **Case** condition produces a True result.

Example

```
' MyResult will return a value of 255 if no valid condition was met
Device = 24HJ128GP502
Declare Xtal = 16
Dim MyByte as Byte
Dim MyResult as Byte
DelayMs 100          ' Wait for things to stabilise
Cls                  ' Clear the LCD
MyResult = 0         ' Clear the result variable before we start
MyByte = 1           ' Variable to base the conditions upon
Select MyByte
  Case 1              ' Is MyByte equal to 1?
    MyResult = 1     ' Load MyResult with 1 if yes
  Case 2              ' Is MyByte equal to 2?
    MyResult = 2     ' Load MyResult with 2 if yes
  Case 3              ' Is MyByte equal to 3?
    MyResult = 3     ' Load MyResult with 3 if yes
  Case Else          ' Otherwise...
    MyResult = 255   ' Load MyResult with 255
EndSelect
Print Dec MyResult   ' Display the result
```

Notes.

Select..Case is simply an advanced form of the **If..Then..Elseif..Else** construct, in which multiple **Elseif** statements are executed by the use of the **Case** command.

Taking a closer look at the **Case** command: -

Case *Conditional_Op Expression*

Where *Conditional_Op* can be an = operator (which is implied if absent), or one of the standard comparison operands <>, <, >, >= or <=. Multiple conditions within the same **Case** can be separated by commas. If, for example, you wanted to run a **Case** block based on a value being less than one or greater than nine, the syntax would look like: -

```
Case < 1, > 9
```

Another way to implement Case is: -

```
Case value1 to value2
```

In this form, the valid range is from *Value1* to *Value2*, inclusive. So if you wished to run a Case block on a value being between the values 1 and 9 inclusive, the syntax would look like: -

```
Case 1 to 9
```

For those of you that are familiar with C or Java, you will know that in those languages the statements in a **Case** block fall through to the next **Case** block unless the keyword break is encountered. In BASIC however, the code under an executed **Case** block jumps to the code immediately after **EndSelect**.

Shown below is a typical **Select...Case** structure with its corresponding If..Then equivalent code alongside.

```
Select Var1
  Case 6, 9, 99, 66
    ' If Var1 = 6 or Var1 = 9 or Var1 = 99 or Var1 = 66 Then
      Print "or Values"
  Case 110 to 200
    ' ElseIf Var1 >= 110 and Var1 <= 200 Then
      Print "and Values"
  Case 100
    ' ElseIf Var1 = 100 Then
      Print "Equal Value"
  Case > 300
    ' ElseIf Var1 > 300 Then
      Print "Greater Value"
  Case Else
    ' Else
      Print "Default Value"
EndSelect
' EndIf
```

See also : **If..Then..Elseif..Else..EndIf.**

Servo

Syntax

Servo *Pin, Rotation Value*

Overview

Control a remote control type servo motor.

Parameters

Pin is a Port.Pin constant that specifies the I/O pin for the attachment of the motor's control terminal.

Rotation Value is a 16-bit (0-65535) constant or **Word** variable that dictates the position of the motor. A value of approx 500 being a rotation to the farthest position in a direction and approx 2500 being the farthest rotation in the opposite direction. A value of 1500 would normally centre the servo but this depends on the motor type.

Example

```
' Control a servo motor attached to pin 3 of PORTB

Device = 24HJ128GP502
Declare Xtal = 16

Dim Pos as Word           ' Servo Position
Symbol Pin = PORTB.3     ' Alias the servo pin

Pos = 1500                ' Centre the servo
PORTA = 0                 ' PORTA lines low to read buttons
TRISA = %00000111       ' Enable the button pins as inputs

' Check any button pressed to move servo
While
  If PORTA.0 = 0 And Pos < 3000 Then Inc Pos   ' Move servo left
  If PORTA.1 = 0 Then Pos = 1500              ' Centre servo
  If PORTA.2 = 0 And Pos > 0 Then Dec Pos     ' Move servo right
  Servo Pin, Pos
  DelayMs 5                                  ' Servo update rate
  Hrsout "Position=", Dec Pos, 13
Wend
```

Notes.

Servos of the sort used in radio-controlled models are finding increasing applications in this robotics age we live in. They simplify the job of moving objects in the real world by eliminating much of the mechanical design. For a given signal input, you get a predictable amount of motion as an output.

To enable a servo to move it must be connected to a 5 Volt power supply capable of delivering an Ampere or more of peak current. It then needs to be supplied with a positioning signal. The signal is normally a 5 Volt, positive-going pulse between 1 and 2 milliseconds (ms) long, repeated approximately 50 times per second.

The width of the pulse determines the position of the servo. Since a servo's travel can vary from model to model, there is not a definite correspondence between a given pulse width and a particular servo angle, however most servos will move to the centre of their travel when receiving 1.5ms pulses.

Servos are closed-loop devices. This means that they are constantly comparing their commanded position (proportional to the pulse width) to their actual position (proportional to the resistance of an internal potentiometer mechanically linked to the shaft). If there is more than a small difference between the two, the servo's electronics will turn on the motor to eliminate the error. In addition to moving in response to changing input signals, this active error correction means that servos will resist mechanical forces that try to move them away from a commanded position. When the servo is unpowered or not receiving positioning pulses, the output shaft may be easily turned by hand. However, when the servo is powered and receiving signals, it won't move from its position.

Driving servos with Proton24 is extremely easy. The **Servo** command generates a pulse in 1 microsecond (μs) units, so the following code would command a servo to its centred position and hold it there: -

```
Do
  Servo PORTA.0, 1500
  DelayMs 20
Loop
```

The 20ms delay ensures that the program sends the pulse at the standard 50 pulse-per-second rate. However, this may be lengthened or shortened depending on individual motor characteristics.

The **Servo** command is oscillator independent and will always produce 1us pulses regardless of the crystal frequency used.

See also : [Pulseout](#).

SetBit

Syntax

SetBit *Variable, Index*

Overview

Set a bit of a variable or register using a variable index to the bit of interest.

Parameters

Variable is a user defined variable, of type **Byte**, **Word**, or **Dword**.

Index is a constant, variable, or expression that points to the bit within *Variable* that requires setting.

Example

```
' Clear then Set each bit of variable ExVar
Device = 24HJ128GP502
Declare Xtal = 16
Dim ExVar as Byte
Dim Index as Byte

Cls
ExVar = %11111111
While                                     ' Create an infinite loop
  For Index = 0 to 7                       ' Create a loop for 8 bits
    ClearBit ExVar, Index                  ' Clear each bit of ExVar
    Print At 1,1,Bin8 ExVar                ' Display the binary result
    DelayMs 100                            ' Slow things down to see what's happening
  Next                                     ' Close the loop
  For Index = 7 to 0 Step -1               ' Create a loop for 8 bits
    SetBit ExVar, Index                    ' Set each bit of ExVar
    Print At 1,1,Bin8 ExVar                ' Display the binary result
    DelayMs 100                            ' Slow things down to see what's happening
  Next                                     ' Close the loop
Wend                                       ' Do it forever
```

Notes.

There are many ways to set a bit within a variable, however, each method requires a certain amount of manipulation, either with rotates, or alternatively, the use of indirect addressing. Each method has its merits, but requires a certain amount of knowledge to accomplish the task correctly. The **SetBit** command makes this task extremely simple using a register rotate method, however, this is not necessarily the quickest method, or the smallest, but it is the easiest. For speed and size optimisation, there is no shortcut to experience.

To set a known constant bit of a variable or register, then access the bit directly using PORT.n.

```
PORTA.1 = 1
or
Var1.4 = 1
```

If a Port is targeted by **SetBit**, the TRIS register is **not** affected.

See also : **ClearBit, GetBit, LoadBit.**

SetPin

Syntax

SetPin *Pin Number*

Overview

Make a Port's pin an output and set it high using a variable as the pin's number.

Parameters

Pin Number can be a variable or constant or expression that holds a value from 0 to the amount of I/O pins on the device. A value of 0 will be **PORTA.0**, if present, 1 will be **PORTA.1**, 16 will be **PORTB.0** etc...

Example

```
' Clear then Set each pin of PORTB
Device = 24HJ128GP502
Declare Xtal = 16
Dim PinNumber as Byte

High PORTB                                     ' Make PORTB high before we start
Do                                              ' Create a loop
  For PinNumber = 16 to 31                     ' Create a loop for 16 pins
    ClearPin PinNumber                         ' Clear each pin of PORTB
    DelayMs 100                                ' Slow things down to see what's happening
  Next                                         ' Close the loop
  For Index = 16 to 31                         ' Create a loop for 16 pins
    SetPin PinNumber                           ' Set each pin of PORTB
    DelayMs 100                                ' Slow things down to see what's happening
  Next                                         ' Close the loop
Loop                                           ' Do it forever
```

Notes.

There are many ways to set a pin of an I/O port, however, each method requires a certain amount of manipulation, either with rotates, or alternatively, the use of indirect addressing. Each method has its merits, but requires a certain amount of knowledge to accomplish the task correctly. The **SetPin** command makes this task extremely simple using a variable as the pin number, however, this is not necessarily the quickest method, or the smallest, but it is the easiest. For speed and size optimisation, there is no shortcut to experience.

To set a known constant pin number of a port, access the pin directly using the **High** command

```
High PORTA.1
```

Each pin number has a designated name. These are Pin_A0, Pin_A1, Pin_A2, Pin_B0...Pin_B15, Pin_C0...Pin_C15, Pin_D0...Pin_D15 to Pin_L15 etc... Each of the names has a relevant value, for example, Pin_A0 has the value 0, Pin_B0 has the value 16, up to Pin_J15, which has the value 143.

These can be used to pass a relevant pin number to a Procedure. For example:

```
,  
, Flash an LED attached to PORTB.0 via a procedure  
, Then flash an LED attached to PORTB.1 via the same procedure  
,  
Device = 24HJ128GP502  
Declare Xtal = 16  
  
Do ' Create an infinite loop  
    FlashPin(Pin_B0) ' Call the procedure to flash PORTB.0  
    FlashPin(Pin_B1) ' Call the procedure to flash PORTB.1  
Loop ' Do it forever  
,  
, Make a pin high then low for 500ms using a variable as the pin to adjust  
,  
Proc FlashPin(pPinNumber As Byte)  
    Output pPinNumber ' Make the pin an output  
    SetPin pPinNumber ' Bring the pin high  
    DelayMs 500 ' Wait for 500 milliseconds  
    ClearPin pPinNumber ' Bring the pin low  
    DelayMs 500 ' Wait for 500 milliseconds  
EndProc
```

Example 2

```
, Clear then Set each pin of PORTC  
Device = 24HJ128GP502  
Declare Xtal = 16  
  
Dim PinNumber as Byte  
  
High PORTC ' Make PORTC output high before we start  
Do ' Create a loop  
    For PinNumber = Pin_C0 to Pin_C7 ' Create a loop for 8 pins  
        ClearPin PinNumber ' Clear each pin of PORTC  
        DelayMs 100 ' Slow things down to see what's happening  
    Next ' Close the loop  
    For PinNumber = Pin_C0 to Pin_C7 ' Create a loop for 8 pins  
        SetPin PinNumber ' Set each pin of PORTC  
        DelayMs 100 ' Slow things down to see what's happening  
    Next ' Close the loop  
Loop ' Do it forever
```

See also : **ClearPin, Low, High.**

Set

Syntax

Set *Variable* or *Variable.Bit* or *Pin Number*

Overview

Place a variable or bit in a high state. For a variable, this means setting all the bits to 1. For a bit this means setting it to 1.

Parameters

Variable can be any variable or register.

Variable.Bit can be any variable and bit combination.

Pin Number can be a variable or constant or expression that holds a value from 0 to the amount of I/O pins on the device. A value of 0 will be **PORTA.0**, if present, 1 will be **PORTA.1**, 16 will be **PORTB.0** etc... For a variable *Pin Number*, see **SetPin**.

Example

```
Set MyVar.3      ' Set bit 3 of MyVar
Set MyByte      ' Load MyByte with the value of 255
Set SR.0        ' Set the Carry flag high
Set Array       ' Set all of an Array variable.
Set String1     ' Set all of a String variable. i.e. set to spaces (ASCII 32)
Set             ' Load all RAM with 255
Set 0           ' Set PORTA.0
```

Notes.

Set does not alter the TRIS register if a Port is targeted.

If no variable follows the **Set** command then all user RAM will be loaded with the value 255.

See also : **Clear, High, Low.**

Shin

Syntax

Shin *dpin, cpin, mode, [result { \bits } { ,result { \bits }...}]*

or

Var = **Shin** *dpin, cpin, mode, shifts*

Overview

Shift data in from a synchronous-serial device.

Parameters

Dpin is a Port.Pin constant that specifies the I/O pin that will be connected to the synchronous-serial device's data output. This pin's I/O direction will be changed to input and will remain in that state after the instruction is completed.

Cpin is a Port.Pin constant that specifies the I/O pin that will be connected to the synchronous-serial device's clock input. This pin's I/O direction will be changed to output.

Mode is a constant that tells **Shin** the order in which data bits are to be arranged and the relationship of clock pulses to valid data. Below are the symbols, values, and their meanings: -

Symbol	Value	Description
MsbPre MsbPre_L	0	Shift data in highest bit first. Read data before sending clock. Clock idles low
LsbPre LsbPre_L	1	Shift data in lowest bit first. Read data before sending clock. Clock idles low
MsbPost MsbPost_L	2	Shift data in highest bit first. Read data after sending clock. Clock idles low
LsbPost LsbPost_L	3	Shift data in highest bit first. Read data after sending clock. Clock idles low
MsbPre_H	4	Shift data in highest bit first. Read data before sending clock. Clock idles high
LsbPre_H	5	Shift data in lowest bit first. Read data before sending clock. Clock idles high
MsbPost_H	6	Shift data in highest bit first. Read data after sending clock. Clock idles high
LsbPost_H	7	Shift data in lowest bit first. Read data after sending clock. Clock idles high

Result is a bit, byte, or word variable in which incoming data bits will be stored.

Bits is an optional constant specifying how many bits (1-16) are to be input by **Shin**. If no *bits* entry is given, **Shin** defaults to 8 bits.

Shifts informs the **Shin** command as to how many bit to shift in to the assignment variable, when used in the inline format.

Notes.

Shin provides a method of acquiring data from synchronous-serial devices, without resorting to the hardware SPI modules resident on some devices. Data bits may be valid after the rising or falling edge of the clock line. This kind of serial protocol is commonly used by controller peripherals such as ADCs, DACs, clocks, memory devices, etc.

The **Shin** instruction causes the following sequence of events to occur: -

Makes the clock pin (cpin) output low.

Makes the data pin (dpin) an input.

Copies the state of the data bit into the msb (lsb-modes) or lsb (msb modes) either before (-pre modes) or after (-post modes) the clock pulse.

Pulses the clock pin high.

Shifts the bits of the result left (msb- modes) or right (lsb-modes).

Repeats the appropriate sequence of getting data bits, pulsing the clock pin, and shifting the result until the specified number of bits is shifted into the variable.

Making **Shin** work with a particular device is a matter of matching the mode and number of bits to that device's protocol. Most manufacturers use a timing diagram to illustrate the relationship of clock and data.

```
Symbol CLK = PORTB.0
Symbol DTA = PORTB.1
Shin DTA, CLK, MsbPre, [Var1]      ' Shift in msb-first, pre-clock.
```

In the above example, both **Shin** instructions are set up for msb-first operation, so the first bit they acquire ends up in the msb (leftmost bit) of the variable.

The post-clock Shift in, acquires its bits after each clock pulse. The initial pulse changes the data line from 1 to 0, so the post-clock Shift in returns %01010101.

By default, **Shin** acquires eight bits, but you can set it to shift any number of bits from 1 to 16 with an optional entry following the variable name. In the example above, substitute this for the first **Shin** instruction: -

```
Shin DTA, CLK, MsbPre, [Var1\4] ' Shift in 4 bits.
```

Some devices return more than 16 bits. For example, most 8-bit shift registers can be daisy-chained together to form any multiple of 8 bits; 16, 24, 32, 40... You can use a single **Shin** instruction with multiple variables.

Each variable can be assigned a particular number of bits with the backslash (\) option. Modify the previous example: -

```
' 5 bits into Var1; 8 bits into Var2.
Shin DTA, CLK, MsbPre, [Var1\5, Var2]
Print "1st variable: ", Bin8 Var1
Print "2nd variable: ", Bin8 Var2
```

Inline Shin Command.

The structure of the inline **Shin** command is: -

Var = **Shin** dpin, cpin, mode, shifts

DPin, *CPin*, and *Mode* have not changed in any way, however, the InLine structure has a new operand, namely *Shifts*. This informs the **Shin** command as to how many bit to shift in to the assignment variable. For example, to shift in an 8-bit value from a serial device, we would use: -

```
Var1 = Shin DTA, CLK, MsbPre, 8
```

To shift 16-bits into a **Word** variable: -

```
MyWord = Shin DTA, CLK, MsbPre, 16
```

Shout

Syntax

Shout *Dpin*, *Cpin*, *Mode*, [*OutputData* {\Bits} {, *OutputData* {\Bits}..}]

Overview

Shift data out to a synchronous serial device.

Parameters

Dpin is a Port.Pin constant that specifies the I/O pin that will be connected to the synchronous serial device's data input. This pin will be set to output mode.

Cpin is a Port.Pin constant that specifies the I/O pin that will be connected to the synchronous serial device's clock input. This pin will be set to output mode.

Mode is a constant that tells **Shout** the order in which data bits are to be arranged. Below are the symbols, values, and their meanings: -

Symbol	Value	Description
LsbFirst LsbFirst_L	0	Shift data out lowest bit first. Clock idles low
MsbFirst MsbFirst_L	1	Shift data out highest bit first. Clock idles low
LsbFirst_H	4	Shift data out lowest bit first. Clock idles high
MsbFirst_H	5	Shift data out highest bit first. Clock idles high

OutputData is a variable, constant, or expression containing the data to be sent.

Bits is an optional constant specifying how many bits are to be output by **Shout**. If no *Bits* entry is given, **Shout** defaults to 8 bits.

Notes.

Shin and **Shout** provide a method of acquiring data from synchronous serial devices. Data bits may be valid after the rising or falling edge of the clock line. This kind of serial protocol is commonly used by controller peripherals like ADCs, DACs, clocks, memory devices, etc.

At their heart, synchronous-serial devices are essentially shift-registers; trains of flip flops that receive data bits in a bucket brigade fashion from a single data input pin. Another bit is input each time the appropriate edge (rising or falling, depending on the device) appears on the clock line.

The **Shout** instruction first causes the clock pin to output low and the data pin to switch to output mode. Then, **Shout** sets the data pin to the next bit state to be output and generates a clock pulse. **Shout** continues to generate clock pulses and places the next data bit on the data pin for as many data bits as are required for transmission.

Making **Shout** work with a particular device is a matter of matching the mode and number of bits to that device's protocol. Most manufacturers use a timing diagram to illustrate the relationship of clock and data. One of the most important items to look for is which bit of the data should be transmitted first; most significant bit (MSB) or least significant bit (LSB).

Example

```
Shout DTA, CLK, MsbFirst, [250]
```

In the above example, the **Shout** command will write to I/O pin DTA (the *Dpin*) and will generate a clock signal on I/O CLK (the *Cpin*). The **Shout** command will generate eight clock pulses while writing each bit (of the 8-bit value 250) onto the data pin (*Dpin*). In this case, it will start with the most significant bit first as indicated by the *Mode* value of **MsbFirst**.

By default, **Shout** transmits eight bits, but you can set it to shift any number of bits from 1 to 16 with the *Bits* argument. For example: -

```
Shout DTA, CLK, MsbFirst, [250\4]
```

Will only output the lowest 4 bits (%0000 in this case). Some devices require more than 16 bits. To solve this, you can use a single **Shout** command with multiple values. Each value can be assigned a particular number of bits with the *Bits* argument. As in: -

```
Shout DTA, CLK, MsbFirst, [250\4, 1045\16]
```

The above code will first shift out four bits of the number 250 (%1111) and then 16 bits of the number 1045 (%0000010000010101). The two values together make up a 20 bit value.

See also : **Shin.**

Sleep

Syntax

Sleep { *Length* }

Overview

Places the microcontroller into low power mode for approx *n* seconds.

Parameters

Length is an optional variable or constant (1-16383) that specifies the duration of sleep in approximate seconds. If length is omitted, then the **Sleep** command is assumed to be the assembler mnemonic, which means the microcontroller will sleep continuously, or until an internal or external influence wakes it up.

Example

```
Symbol MyLED = PORTA.0
While
  High MyLED           ' Turn LED on.
  DelayMs 1000         ' Wait 1 second.
  Low MyLED            ' Turn LED off.
  Sleep 60             ' Sleep for 1 minute.
Wend
```

Notes.

Sleep will place the device into a low power mode for the specified period of seconds. Period is 14-bits, so delays of up to 16383 seconds are the limit. **Sleep** uses the Watchdog Timer so it is independent of the oscillator frequency.

The **Sleep** command is used to put the microcontroller in a low power mode without resetting the registers. Allowing continual program execution upon waking up from the **Sleep** period.

The watchdog must be enabled and set to a postscaler value of 1:256 for sleep to work correctly.

Sound

Syntax

Sound *Pin*, [*Note*, *Duration* {, *Note*, *Duration*...}]

Overview

Generates tone and/or white noise on the specified *Pin*. *Pin* is automatically made an output.

Parameters

Pin is a Port.Pin constant that specifies the output pin on the device.

Note can be an 8-bit variable or constant. 0 is silence. Notes 1-127 are tones. Notes 128-255 are white noise. Tones and white noises are in ascending order (i.e. 1 and 128 are the lowest frequencies, 127 and 255 are the highest). Note 1 is approx 78.74Hz and Note 127 is approx 10,000Hz.

Duration can be an 8-bit variable or constant that determines how long the *Note* is played in approx 10ms increments.

Example

```
' Star Trek The Next Generation...Theme and ship take-off
Device = 24HJ128GP502
Declare Xtal = 16

Dim Loop as Byte
Symbol Pin = PORTB.0

Theme:
Sound Pin, [50,60,70,20,85,120,83,40,70,20,50,20,70,20,90,120,90,20,98,160]
DelayMs 500
For Loop = 128 to 255      ' Ascending white noises
    Sound Pin, [Loop,2]    ' For warp drive sound
Next
Sound Pin, [43,80,63,20,77,20,71,80,51,20,-
            90,20,85,140,77,20,80,20,85,20,-
            90,20,80,20,85,60,90,60,92,60,87,-
            60,96,70,0,10,96,10,0,10,96,10,0,-
            10,96,30,0,10,92,30,0,10,87,30,0,-
            10,96,40,0,20,63,10,0,10,63,10,0,-
            10,63,10,0,10,63,20]
DelayMs 10000
GoTo Theme
```

Notes.

With the excellent I/O characteristics of the PIC24[®] and dsPIC33[®], a speaker can be driven through a capacitor directly from the pin of the microcontroller. The value of the capacitor should be determined based on the frequencies of interest and the speaker load. Piezo speakers can be driven directly.

See also : Freqout, DTMFout.

Stop

Syntax Stop

Overview

Stop halts program execution by sending the microcontroller into an infinite loop.

Example

```
If A > 12 Then Stop  
  { code data }
```

If variable A contains a value greater than 12 then stop program execution. *code data* will not be executed.

Notes.

Although **Stop** halts the microcontroller in its tracks it does not prevent any code listed in the BASIC source after it from being compiled.

See also : End, Sleep, Snooze.

Strn

Syntax

Strn *Byte Array* = *Item*

Overview

Load a **Byte Array** with null terminated data, which can be likened to creating a pseudo String variable.

Parameters

Byte Array is the variable that will be loaded with values.

Item can be another **Strn** command, a **Str** command, **Str\$** command, or a quoted character string

Example

```
' Load the Byte Array String1 with null terminated characters

Device = 24HJ128GP502
Declare Xtal = 16
Dim String1[21] as Byte      ' Create a Byte array with 21 elements

DelayMs 100                  ' Wait for things to stabilise
Cls                          ' Clear the LCD
Strn String1 = "Hello World"
'
' Load String1 with characters and null terminate it
'
Print Str String1           ' Display the string
```

See also: **Arrays as Strings, Str\$.**

Str\$

Syntax

Str Byte Array = **Str\$** (Modifier Variable)

or

String = **Str\$** (Modifier Variable)

Overview

Convert a Decimal, Hex, Binary, or Floating Point value or variable into a null terminated string held in a **Byte array**, or a **String** variable. For use only with the **Str** and **Strn** commands, and real String variables.

Parameters

Modifier is one of the standard modifiers used with **Print**, **Rsout**, **Hserout** etc. See list below. **Variable** is a variable that holds the value to convert. This may be a **Bit**, **Byte**, **Word**, **Dword**, or **Float**.

Byte Array must be of sufficient size to hold the resulting conversion and a terminating null character (0).

String must be of sufficient size to hold the resulting conversion.

Notice that there is no comma separating the Modifier from the Variable. This is because the compiler borrows the format and subroutines used in **Print**. Which is why the modifiers are the same: -

Bin{1..32}	Convert to binary digits
Dec{1..10}	Convert to decimal digits
Hex{1..8}	Convert to hexadecimal digits
Sbin{1..32}	Convert to signed binary digits
Sdec{1..10}	Convert to signed decimal digits
Shex{1..8}	Convert to signed hexadecimal digits
Ibin{1..32}	Convert to binary digits with a preceding '%' identifier
Idec{1..10}	Convert to decimal digits with a preceding '#' identifier
Ihex{1..8}	Convert to hexadecimal digits with a preceding '\$' identifier
ISbin{1..32}	Convert to signed binary digits with a preceding '%' identifier
ISdec{1..10}	Convert to signed decimal digits with a preceding '#' identifier
IShex{1..8}	Convert to signed hexadecimal digits with a preceding '\$' identifier

Example 1

```
' Convert a Word variable to a String of characters in a Byte array.
Device = 24HJ128GP502
Declare Xtal = 16
,
' Create a byte array to hold converted value, and null terminator
Dim MyString as String * 12
Dim MyWord1 as Word

DelayMs 100           ' Wait for things to stabilise
Cls                   ' Clear the LCD
MyWord1 = 1234        ' Load the variable with a value
Strn MyString = Str$(Dec MyWord1) ' Convert the Integer to a String
Print MyString        ' Display the string
```

Example 2

```
' Convert a Dword variable to a String of characters in a Byte array.
Device = 24HJ128GP502
Declare Xtal = 16

Dim MyString as String * 12
Dim MyDword1 as Dword
DelayMs 100           ' Wait for things to stabilise
Cls                  ' Clear the LCD
MyDword1 = 1234       ' Load the variable with a value
Strn MyString = Str$(Dec MyDword1) ' Convert the Integer to a String
Print MyString       ' Display the string
```

Example 3

```
' Convert a Float variable to a String of characters in a Byte array.
Device = 24HJ128GP502
Declare Xtal = 16

Dim MyString as String * 12
Dim MyFloat1 as Float
DelayMs 100           ' Wait for things to stabilise
Cls                  ' Clear the LCD
MyFloat1 = 3.14       ' Load the variable with a value
Strn MyString = Str$(Dec MyFloat1) ' Convert the Float to a String
Print MyString       ' Display the string
```

Example 4

```
' Convert a Word variable to a Binary String of characters in an array.
Device = 24HJ128GP502
Declare Xtal = 16

Dim MyString as String * 32
Dim MyWord1 as Word
DelayMs 100           ' Wait for things to stabilise
Cls                  ' Clear the LCD
MyWord1 = 1234        ' Load the variable with a value
Strn MyString = Str$(Bin MyWord1) ' Convert the Integer to a String
Print MyString       ' Display the string
```

If we examine the resulting string (Byte Array) converted with example 2, it will contain: -

character 1, character 2, character 3, character 4, 0

The zero is not character zero, but value zero. This is a null terminated string.

Notes.

The **Byte Array** created to hold the resulting conversion, must be large enough to accommodate all the resulting digits, including a possible minus sign and preceding identifying character. %, \$, or # if the **I** version modifiers are used. The compiler will try and warn you if it thinks the array may not be large enough, but this is a rough guide, and you as the programmer must decide whether it is correct or not. If the size is not correct, any adjacent variables will be overwritten, with potentially catastrophic results.

See also : [Creating and using Strings, Strn, Arrays as Strings.](#)

Swap

Syntax

Swap *Variable, Variable*

Overview

Swap any two variable's values with each other.

Parameters

Variable is the value to be swapped

Example

*' If Dog = 2 and Cat = 10 then by using the swap command
' Dog will now equal 10 and Cat will equal 2.*

```
Var1 = 10           ' Var1 equals 10
Var2 = 20           ' Var2 equals 20
Swap Var1, Var2   ' Var2 now equals 20 and Var1 now equals 10
```

Symbol

Syntax

Symbol Name { = } Value

Overview

Assign an alias to a register, variable, or constant value

Parameters

Name can be any valid identifier.

Value can be any previously declared variable, system register, or a Register.Bit combination. The equals '=' symbol is optional, and may be omitted if desired.

When creating a program it can be beneficial to use identifiers for certain values that don't change: -

```
Symbol Meter = 1
Symbol Centimetre = 100
Symbol Millimetre = 1000
```

This way you can keep your program very readable and if for some reason a constant changes later, you only have to make one change to the program to change all the values. Another good use of the constant is when you have values that are based on other values.

```
Symbol Meter = 1
Symbol Centimetre = Meter / 100
Symbol Millimetre = Centimetre / 10
```

In the example above you can see how the centimetre and millimetre were derived from the Meter.

Another use of the **Symbol** command is for assigning Port.Bit constants: -

```
Symbol LED = PORTA.0
High LED
```

In the above example, whenever the text LED is encountered, Bit-0 of PORTA is actually referenced.

Floating point constants may also be created using **Symbol** by simply adding a decimal point to a value.

```
Symbol PI = 3.14      ' Create a floating point constant named PI
Symbol FlNum = 3.0    ' Create a floating point constant with the value 3
```

Floating point constant can also be created using expressions.

```
' Create a floating point constant holding the result of the expression
Symbol Quanta = 3.3 / 1024
```

Notes.

Symbol cannot create new variables, it simply aliases an identifier to a previously assigned variable, or assigns a constant to an identifier.

Toggle

Syntax

Toggle *Variable* *{.Bit}*

Overview

Reverses a variable or pin. If a Port's pin is chosen as the operand, it will first be set to output mode. i.e. Changing 0 to 1 and 1 to 0.

Parameters

Variable *{.Bit}* can be any valid variable, variable and bit, or Port and Bit combination.

Example

```
High PORTB.0      ' Set bit 0 of PORTB high
Toggle PORTB.0    ' And now reverse the bit

Toggle Var1.0     ' Reverse bit-0 of Var1
Toggle Var1       ' Reverse the whole of Var1
```

See also : **High, Low.**

ToLower

Syntax

Destination String = **ToLower** (*Source String*)

Overview

Convert the characters from a source string to lower case.

Parameters

Destination String can only be a **String** variable, and should be large enough to hold the correct amount of characters extracted from the *Source String*.

Source String can be a **String** variable, or a Quoted String of Characters. The *Source String* can also be a **Byte**, **Word**, **Dword**, **Float** or **Array**, variable, in which case the value contained within the variable is used as a pointer to the start of the Source String's address in RAM. A third possibility for *Source String* is a Label name, in which case a null terminated Quoted String of Characters is read from code memory.

Example 1

```
' Convert the characters from SourceString to lowercase into DestString

Device = 24HJ128GP502
Declare Xtal = 16
Dim SourceString as String * 20 ' Create a String of 20 characters
Dim DestString as String * 20   ' Create another String

SourceString = "HELLO WORLD"    ' Load the source string with characters
DestString = ToLower(SourceString) ' Convert to lowercase
Print DestString                ' Display the result, which will be "hello world"
```

Example 2

```
' Convert the characters from a Quoted Character String to lowercase
' into DestString

Device = 24HJ128GP502
Declare Xtal = 16
Dim DestString as String * 20 ' Create a String of 20 characters

DestString = ToLower("HELLO WORLD") ' Convert to lowercase
Print DestString                ' Display the result, which will be "hello world"
```

Example 3

```
' Convert to lowercase from SourceString into DestString using a pointer to
' SourceString

Device = 24HJ128GP502
Declare Xtal = 16
Dim SourceString as String * 20 ' Create a String of 20 characters
Dim DestString as String * 20   ' Create another String
' Create a Word variable to hold the address of SourceString
Dim StringAddr as Word

SourceString = "HELLO WORLD"    ' Load the source string with characters
' Locate the start address of SourceString in RAM
StringAddr = AddressOf(SourceString)
DestString = ToLower(StringAddr) ' Convert to lowercase
Print DestString                ' Display the result, which will be "hello world"
```

Example 4

*' Convert chars from a code memory string to lowercase
' and place into DestString*

```
Device = 24HJ128GP502
Declare Xtal = 16
Dim DestString as String * 20      ' Create a String of 20 characters
' Create a null terminated string of characters in code memory
Dim Source as Code = "HELLO WORLD", 0

DestString = ToLower(Source)      ' Convert to lowercase
Print DestString                 ' Display the result, which will be "hello world"
```

See also : **Creating and using Strings, Creating and using code memory strings, Len, Left\$, Mid\$, Right\$, Str\$, ToUpper, AddressOf .**

ToUpper

Syntax

Destination String = **ToUpper** (*Source String*)

Overview

Convert the characters from a source string to UPPER case.

Parameters

Destination String can only be a **String** variable, and should be large enough to hold the correct amount of characters extracted from the *Source String*.

Source String can be a **String** variable, or a Quoted String of Characters . The *Source String* can also be a **Byte**, **Word**, **Dword**, **Float** or **Array**, variable, in which case the value contained within the variable is used as a pointer to the start of the Source String's address in RAM. A third possibility for *Source String* is a Label name, in which case a null terminated Quoted String of Characters is read from code memory.

Example 1

```
' Convert the characters from SourceString to UpperCase and place into
' DestString

Device = 24HJ128GP502
Declare Xtal = 16
Dim SourceString as String * 20      ' Create a String of 20 characters
Dim DestString as String * 20       ' Create another String

SourceString = "hello world"        ' Load the source string with characters
DestString = ToUpper(SourceString)  ' Convert to uppercase
Print DestString                    ' Display the result, which will be "HELLO WORLD"
```

Example 2

```
' Convert the chars from a Quoted Character String to UpperCase
' and place into DestString

Device = 24HJ128GP502
Declare Xtal = 16
Dim DestString as String * 20       ' Create a String of 20 characters

DestString = ToUpper("hello world") ' Convert to uppercase
Print DestString                    ' Display the result, which will be "HELLO WORLD"
```

Example 3

```
' Convert to UpperCase from SourceString into DestString using a pointer to
' SourceString

Device = 24HJ128GP502
Declare Xtal = 16
Dim SourceString as String * 20     ' Create a String of 20 characters
Dim DestString as String * 20      ' Create another String
Dim StringAddr as Word              ' Create a Word variable to hold address

SourceString = "hello world"        ' Load the source string with characters
' Locate the start address of SourceString in RAM
StringAddr = AddressOf(SourceString)
DestString = ToUpper(StringAddr)    ' Convert to uppercase
Print DestString                    ' Display the result, which will be "HELLO WORLD"
```

Example 4

```
' Convert chars from a code memory string to uppercase
' and place into DestString

Device = 24HJ128GP502
Declare Xtal = 16
Dim DestString as String * 20 ' Create a String of 20 characters
' Create a null terminated string of characters in code memory
Dim Source as Code = "hello world", 0

DestString = ToUpper(Source) ' Convert to uppercase
Print DestString ' Display the result, which will be "HELLO WORLD"
```

See also : [Creating and using Strings](#), [Creating and using code memory strings](#), [Len](#), [Left\\$](#), [Mid\\$](#), [Right\\$](#), [Str\\$](#), [ToLower](#), [AddressOf](#) .

Touch_Active

Syntax

Assignment Variable = Touch_Active

Overview

Indicates if the graphic LCD's resistive touch membrane has been touched.

Assignment

Assignment Variable can be any valid variable type and holds 1 if the touch screen membrane has been touched with sufficient force.

Example

```
' Demonstrate the Touch_Active command
,
Device = 24HJ128GP502
Declare Xtal = 79.23
Declare Hserial_Baud = 9600          ' USART1 baud rate
Declare Hrsout1_Pin = PORTB.14      ' Select the pin used for TX with USART1
,
' Setup the ADS7846 touchscreen chip's pins
,
Declare Touch_DINPin = PORTB.13     ' Connect to the ADS7846 DIN pin
Declare Touch_DOUTPin = PORTB.12    ' Connect to the ADS7846 DOUT pin
Declare Touch_CLKPin = PORTB.11     ' Connect to the ADS7846 CLK pin
Declare Touch_CSPin = PORTB.9       ' Connect to the ADS7846 CS pin

Include "TouchScreen.inc" ' Load the touchscreen routines into the program

-----
Main:
' Configure the internal oscillator to operate the device at 79.23MHz
,
PLL_Setup(43, 2, 2, $0300)
RPOR7 = 3          ' Make Pin RP14 UITX

While
  If Touch_Active = 1 Then          ' Has the LCD been touched?
    HRSOut "LCD is Touched\r"      ' Yes. So transmit a message serially
    DelayMS 200
  EndIf
Wend

-----
' Configure for internal 7.37MHz oscillator with PLL
' OSC pins are general purpose I/O
,
Config FBS = BWRP_WRPROTECT_OFF, BSS_NO_FLASH, BSS_NO_BOOT_CODE
Config FSS = SWRP_WRPROTECT_OFF, SSS_NO_FLASH, RSS_NO_SEC_RAM
Config FGS = GWRP_OFF, GCP_OFF
Config FOSCSEL = FNOSC_FRCPLL, IESO_ON
Config FOSC = POSCMD_NONE, OSCIOFNC_ON, IOL1WAY_OFF, FCKSM_CSDCMD
Config FWDT = WDTPPOST_PS256, WINDIS_OFF, FWDTEN_OFF
Config FPOR = FPWRT_PWR128, ALTI2C_OFF
Config FICD = ICS_PGD1, JTAGEN_OFF
```

Notes.

The touch screen commands used by the compiler are for use with an ADS7846 touch screen controller device. This device uses an SPI interface and connects to a 4-wire resistive touch screen membrane to give X and Y coordinates, as well as touch pressure.

The routines must be incorporated into the BASIC program by use of an include file named "**TouchScreen.inc**". This is written in Proton24 BASIC so that modifications or improvements are easy. It also exposes how the touch screen is interfaced with.

A suitable circuit for the ADS7846 touch screen controller is shown below:

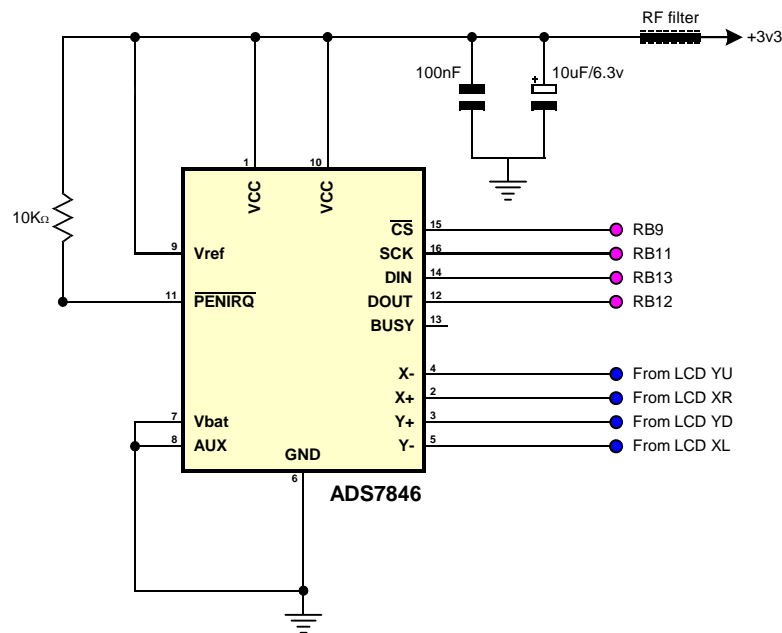

ADS7846 Touch controller circuit

See Also. [Touch_Read](#), [Touch_HotSpot](#)

Touch_Read

Syntax

Assignment Variable = Touch_Read

Overview

Get the X and Y pixel coordinates from the graphic LCD's resistive touch membrane.

Assignment

Assignment Variable can be any valid variable type and holds 1 if the touch screen membrane has been touched within its bounds.

Two variables are loaded with the X and Y pixel coordinates. These are:

Touch_Xpos holds the X position of the touch (0 to 239)

Touch_Ypos holds the Y position of the touch (0 to 319)

Example

```
' Demonstrate the Touch_Read command
,
Device = 24HJ128GP502
Declare Xtal = 79.23
,
' Setup the ADS7846 touchscreen chip's pins
,
Declare Touch_DINPin = PORTB.13      ' Connect to the ADS7846 DIN pin
Declare Touch_DOUTPin = PORTB.12     ' Connect to the ADS7846 DOUT pin
Declare Touch_CLKPin = PORTB.11      ' Connect to the ADS7846 CLK pin
Declare Touch_CSPin = PORTB.9        ' Connect to the ADS7846 CS pin

Include "TouchScreen.inc" ' Load the touchscreen routines into the program

' Configure the internal oscillator to operate the device at 79.23MHz
,
PLL_Setup(43, 2, 2, $0300)
While
  If Touch_Active = 1 Then           ' Has the LCD been touched?
    If Touch_Read = 1 Then          ' Is the touch within bounds?
      HRSOut "X Touch = ", Dec Touch_Xpos, 13
      HRSOut "Y Touch = ", Dec Touch_Ypos, 13
      DelayMS 200
    EndIf
  EndIf
Wend

-----
' Configure for internal 7.37MHz oscillator with PLL
' OSC pins are general purpose I/O
,
Config FBS = BWRP_WRPROTTECT_OFF, BSS_NO_FLASH, BSS_NO_BOOT_CODE
Config FSS = SWRP_WRPROTTECT_OFF, SSS_NO_FLASH, RSS_NO_SEC_RAM
Config FGS = GWRP_OFF, GCP_OFF
Config FOSCSEL = FNOSC_FRCPLL, IESO_ON
Config FOSC = POSCMD_NONE, OSCIOFNC_ON, IOL1WAY_OFF, FCKSM_CSDCMD
Config FWDT = WDTPPOST_PS256, WINDIS_OFF, FWDTEN_OFF
Config FPOR = FPWRT_PWR128, ALTI2C_OFF
Config FICD = ICS_PGD1, JTAGEN_OFF
```

Notes.

The touch screen commands used by the compiler are for use with an ADS7846 touch screen controller device. This device uses an SPI interface and connects to a 4-wire resistive touch screen membrane to give X and Y coordinates, as well as touch pressure.

The routines must be incorporated into the BASIC program by use of an include file named "***TouchScreen.inc***". This is written in Proton24 BASIC so that modifications or improvements are easy. It also exposes how the touch screen is interfaced with.

See Also. `Touch_Active`, `Touch_HotSpot`

Touch_HotSpot

Syntax

Assignment Variable = **Touch_HotSpot** *Xpos Start, Ypos Start, Xpos End, Ypos End*

Overview

Indicate when a user defined area on the graphic LCD's resistive touch membrane has been touched.

Parameters

Assignment Variable can be any valid variable type and holds 1 if the touch screen membrane has been touched within the window's bounds.

Xpos Start can be any valid variable type that holds the X position for the start of the touch window. Can be a value from 0 to the LCD's X resolution.

Ypos Start can be any valid variable type that holds the Y position for the start of the touch window. Can be a value from 0 to the LCD's Y resolution.

Xpos End can be any valid variable type that holds the X position for the end of the touch window. Can be a value from 0 to the LCD's X resolution.

Ypos End can be any valid variable type that holds the Y position for the end of the touch window. Can be a value from 0 to the LCD's Y resolution.

The Windowed area's X and Y start positions are top left of the LCD, as in the other pixel based routines.

Example

```
' Demonstrate the Touch_HotSpot command
'
Device = 24HJ128GP502
Declare Xtal = 79.23
Declare Hserial_Baud = 9600          ' USART1 baud rate
Declare Hrsout1_Pin = PORTB.14      ' Select the pin used for TX with USART1
'
' Setup the touchscreen chip's pins
'
Declare Touch_DINPin = PORTB.13     ' Connect to the ADS7846 DIN pin
Declare Touch_DOUTPin = PORTB.12    ' Connect to the ADS7846 DOUT pin
Declare Touch_CLKPin = PORTB.11     ' Connect to the ADS7846 CLK pin
Declare Touch_CSPin = PORTB.9       ' Connect to the ADS7846 CS pin

Include "TouchScreen.inc" ' Load the touchscreen routines into the program

' Configure the internal oscillator to operate the device at 79.23MHz
'
PLL_Setup(43, 2, 2, $0300)
RPOR7 = 3          ' Make PPS Pin RP14 U1TX
'
' Transmit a message if the LCD is touched within a window 40 pixels square
While
  If Touch_Active = 1 Then          ' Has the LCD been touched?
    Touch_Read                      ' Read the touch X and Y
    If Touch_HotSpot 0, 0, 40, 40 = 1 Then
      HRSOut "Touched at X ", Dec Touch_Xpos, ", Y ", Dec Touch_Ypos, 13
      DelayMS 100
    EndIf
  EndIf
Wend
```

```
-----  
' Configure for internal 7.37MHz oscillator with PLL  
' OSC pins are general purpose I/O  
,  
Config FBS = BWRP_WRPROTECT_OFF, BSS_NO_FLASH, BSS_NO_BOOT_CODE  
Config FSS = SWRP_WRPROTECT_OFF, SSS_NO_FLASH, RSS_NO_SEC_RAM  
Config FGS = GWRP_OFF, GCP_OFF  
Config FOSCSEL = FNOSC_FRCPLL, IESO_ON  
Config FOSC = POSCMD_NONE, OSCIOFNC_ON, IOL1WAY_OFF, FCKSM_CSDCMD  
Config FWDT = WDTPOST_PS256, WINDIS_OFF, FWDTEN_OFF  
Config FPOR = FPWRT_PWR128, ALTI2C_OFF  
Config FICD = ICS_PGD1, JTAGEN_OFF
```

Notes.

The touch screen commands used by the compiler are for use with an ADS7846 touch screen controller device. This device uses an SPI interface and connects to a 4-wire resistive touch screen membrane to give X and Y coordinates, as well as touch pressure.

The routines must be incorporated into the BASIC program by use of an include file named "***TouchScreen.inc***". This is written in Proton24 BASIC so that modifications or improvements are easy. It also exposes how the touch screen is interfaced with.

See Also. [Touch_Active](#), [Touch_Read](#).

Toshiba_Command

Syntax

Toshiba_Command *Command, Value*

Overview

Send a command with or without parameters to a Toshiba T6963 graphic LCD.

Parameters

Command can be a constant, variable, or expression, that contains the command to send to the LCD. This will always be an 8-bit value.

Value can be a constant, variable, or expression, that contains an 8-bit or 16-bit parameter associated with the command. An 8-bit value will be sent as a single parameter, while a 16-bit value will be sent as two parameters. Parameters are optional as some commands do not require any. Therefore if no parameters are included, only a command is sent to the LCD.

Because the size of the parameter is vital to the correct operation of specific commands, you can force the size of the parameter sent by issuing either the text “**Byte**” or “**Word**” prior to the parameter’s value.

```
Toshiba_Command $C0, Byte $FF01 ' Send the low byte of the 16-bit value.  
Toshiba_Command $C0, Word $01   ' Send a 16-bit value regardless.
```

The explanation of each command is too lengthy for this document, however they can be found in the Toshiba T6963C datasheet.

Example

```
' Toshiba T6963C Command demo  
,  
Device = 24FJ64GA002  
Declare Xtal = 16  
,  
' Toshiba T6963C graphic LCD Pin configuration  
,  
Declare LCD_Type = Toshiba           ' LCD's type is Toshiba T6963C  
Declare LCD_DTPort = PORTB.Byte0     ' The LCD's 8-bit Data port  
Declare LCD_WRPin = PORTB.12         ' The LCD's WR pin  
Declare LCD_RDPin = PORTB.11         ' The LCD's RD pin  
Declare LCD_CEPin = PORTB.10         ' The LCD's CE pin  
Declare LCD_CDPin = PORTB.8          ' The LCD's CD pin  
Declare LCD_RSTPin = PORTB.9         ' The LCD's RST pin (optional)  
,  
' Toshiba T6963C graphic LCD setup configuration  
,  
Declare LCD_Font_Width = 8           ' The font width ( 6 or 8 )  
Declare LCD_X_Res = 128               ' The X resolution of the LCD  
Declare LCD_Y_Res = 64                ' The Y resolution of the LCD  
Declare LCD_Text_Home_Address = 0     ' The home address of the LCD  
Declare LCD_RAM_Size = 8192           ' The amount of RAM the LCD contains  
Declare LCD_Text_Pages = 1           ' The amount of text pages required  
  
Include "T6963C.inc" ' Load the Toshiba T6963C routines into the program
```

```
Dim PanLoop As Byte
Dim Ypos As Byte
-----
Main:
 Cls                               ' Clear Text and Graphic RAM
,
' Place text on two screen pages
,
  For Ypos = 1 To 6
    Print At Ypos,0,"  THIS IS PAGE ONE      THIS IS PAGE TWO"
  Next
,
' Draw a box around the display
,
  Line 1,0,0,127,0                 ' Top line
  LineTo 1,127,63                  ' Right line
  LineTo 1,0,63                    ' Bottom line
  LineTo 1,0,0                     ' Left line
,
' Pan from one screen to the next then back
,
  While                             ' Create an infinite loop
,
  ' Increment the Text home address
,
  For PanLoop = 0 To 23
    Toshiba_Command cT6963_SET_TEXT_HOME_ADDRESS , Word PanLoop
    DelayMS 200
  Next
  DelayMS 200
,
  ' Decrement the Text home address
,
  For PanLoop = 23 To 0 Step -1
    Toshiba_Command cT6963_SET_TEXT_HOME_ADDRESS , Word PanLoop
    DelayMS 200
  Next
  DelayMS 200
Wend                               ' Do it forever
```

Notes.

When the Toshiba LCD's **Declares** are issued within the BASIC program, several internal variables and constants are automatically created that contain the Port and Bits used by the actual interface and also some constant values holding valuable information concerning the LCD's RAM boundaries and setup. These variables and constants can be used within the BASIC or Assembler environment. The internal variables and constants are: -

Variables.

__LCD_DTPort	The Port where the LCD's data lines are attached.
__LCD_WRPot	The Port where the LCD's WR pin is attached.
__LCD_RDPot	The Port where the LCD's RD pin is attached.
__LCD_CEPot	The Port where the LCD's CE pin is attached.
__LCD_CDPot	The Port where the LCD's CD pin is attached.
__LCD_RSTPot	The Port where the LCD's RST pin is attached.

Constants.

<code>__LCD_Type</code>	The type of LCD targeted. 0 = Alphanumeric, 1 = KS0108, 2 = Toshiba.
<code>__LCD_WRPin</code>	The Pin where the LCD's WR line is attached.
<code>__LCD_RDPin</code>	The Pin where the LCD's RD line is attached.
<code>__LCD_CEPin</code>	The Pin where the LCD's CE line is attached.
<code>__LCD_CDPin</code>	The Pin where the LCD's CD line is attached.
<code>__LCD_RSTPin</code>	The Pin where the LCD's RST line is attached.
<code>__LCD_Text_Pages</code>	The amount of TEXT pages chosen.
<code>__LCD_Graphic_Pages</code>	The amount of Graphic pages chosen.
<code>__LCD_RAM_Size</code>	The amount of RAM that the LCD contains.
<code>__LCD_X_Res</code>	The X resolution of the LCD. i.e. Horizontal pixels.
<code>__LCD_Y_Res</code>	The Y resolution of the LCD. i.e. Vertical pixels.
<code>__LCD_Font_Width</code>	The width of the font. i.e. 6 or 8.
<code>__LCD_Text_AREA</code>	The amount of characters on a single line of TEXT RAM.
<code>__LCD_Graphic_AREA</code>	The amount of characters on a single line of Graphic RAM.
<code>__LCD_Text_Home_Address</code>	The Starting address of the TEXT RAM.
<code>__LCD_Graphic_Home_Address</code>	The Starting address of the Graphic RAM.
<code>__LCD_CGRAM_Home_Address</code>	The Starting address of the CG RAM.
<code>__LCD_End_OF_Graphic_RAM</code>	The Ending address of Graphic RAM.
<code>__LCD_CGRAM_OFFSET</code>	The Offset value for use with CG RAM.

Notice that each name has two underscores preceding it. This should ensure that duplicate names are not defined within the BASIC environment.

It may not be apparent straight away why the variables and constants are required, however, the Toshiba LCDs are capable of many tricks such as panning, page flipping, text manipulation etc, and all these require some knowledge of RAM boundaries and specific values relating to the resolution of the LCD used.

See also : `LCDRead`, `LCDWrite`, `Pixel`, `Plot`, `Toshiba_UDG`, `UnPlot`.

Toshiba_UDG

Syntax

Toshiba_UDG *Character*, [*Value* {, *Values* }]

Overview

Create **U**ser **D**efined **G**raphics for a Toshiba T6963 graphic LCD.

Parameters

Character can be a constant, variable, or expression, that contains the character to define. User defined characters start from 160 to 255.

Values is a list of constants, variables, or expressions, that contain the information to build the User Defined character. There are also some modifiers that can be used in order to access UDG data from various tables.

Example

```
' Toshiba T6963C UDG (User Defined Graphics) demo
,
  Device = 24FJ64GA002
  Declare Xtal = 16
,
' Toshiba T6963C graphic LCD Pin configuration
,
  Declare LCD_Type = Toshiba           ' LCD's type is Toshiba T6963C
  Declare LCD_DTPort = PORTB.Byte0     ' The LCD's 8-bit Data port
  Declare LCD_WRPin = PORTB.12         ' The LCD's WR pin
  Declare LCD_RDPin = PORTB.11         ' The LCD's RD pin
  Declare LCD_CEPin = PORTB.10         ' The LCD's CE pin
  Declare LCD_CDPin = PORTB.8          ' The LCD's CD pin
  Declare LCD_RSTPin = PORTB.9         ' The LCD's RST pin (optional)
,
' Toshiba T6963C graphic LCD setup configuration
,
  Declare LCD_Font_Width = 8           ' The font width ( 6 or 8)
  Declare LCD_X_Res = 128              ' The X resolution of the LCD
  Declare LCD_Y_Res = 64               ' The Y resolution of the LCD
  Declare LCD_Text_Home_Address = 0    ' The home address of the LCD
  Declare LCD_RAM_Size = 8192          ' The amount of RAM the LCD contains
  Declare LCD_Text_Pages = 2           ' The amount of text pages required

  Include "T6963C.inc"                 ' Load the Toshiba T6963C routines into the program
,
-----
Main:
  Dim UDG_Array[10] As Byte = $18, $18, $99, $DB, $7E, $3C, $18, $18
  Dim UDG_Code As Code = $30, $18, $0C, $FF, $FF, $0C, $18, $30

  Cls Text                             ' Clear Text RAM
,
' Print the user defined graphic characters 160, 161 and 162 on the LCD
,
  Print At 1,0,"Char 160 = ",160,_,_
        At 2,0,"Char 161 = ",161,_,_
        At 3,0,"Char 162 = ",162
```

```

,
, Create the UDG (User Defined Graphics) for three characters
,
Toshiba_Udg 160,[UDG_Code\8]
Toshiba_Udg 161,[Str UDG_Array\8]
Toshiba_Udg 162,[$0C, $18, $30, $FF, $FF, $30, $18, $0C]
    
```

Notes.

User Defined Graphic values can be stored in code memory, and retrieved by the use of a label name associated with the **Dim as Code** table:

```

Dim UDG_2 as Code = $30, $18, $0C, $FF, $FF, $0C, $18, $30

Toshiba_UDG 161, [UDG_2\8]
    
```

The use of the **Str** modifier will retrieve values stored in an array, however, this is not recommended as it will waste precious RAM.

The Toshiba LCD's font is designed in an 8x8 grid or a 6x8 grid depending on the font size chosen. The diagram below shows a designed character and its associated values.

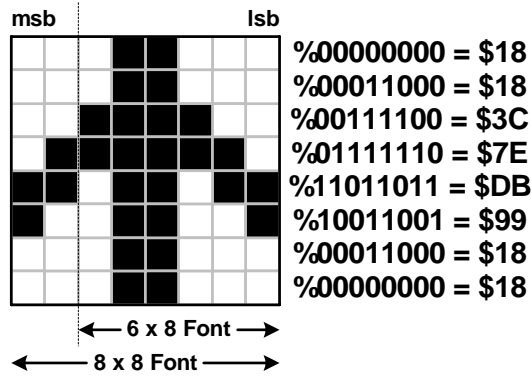

See also : LCDRead, LCDWrite, Pixel, Plot, Toshiba_Command, UnPlot.

UnPlot

Syntax

UnPlot *Ypos, Xpos*

Overview

Clear an individual pixel on a graphic LCD.

Parameters

Xpos can be a constant, variable, or expression, pointing to the X-axis location of the pixel to clear. This must be a value of 0 to the X resolution of the LCD. Where 0 is the far left row of pixels.

Ypos can be a constant, variable, or expression, pointing to the Y-axis location of the pixel to clear. This must be a value of 0 to the Y resolution of the LCD. Where 0 is the top column of pixels.

Example

```
Device = 24HJ128GP502
Declare Xtal = 16
,
' KS0108 graphic LCD declares
,
Declare LCD_Type = KS0108           ' Setup for a KS0108 graphic LCD
Declare LCD_DTPort = PORTB.Byte0
Declare LCD_CS1Pin = PORTB.8
Declare LCD_CS2Pin = PORTB.9
Declare LCD_ENPin = PORTB.10
Declare LCD_RSPin = PORTB.11
Declare LCD_RWPin = PORTB.12

Dim Xpos as Byte

Cls                               ' Clear the LCD
,
' Draw a line across the LCD
,
While                             ' Create an infinite loop
  For Xpos = 0 to 127
    Plot 20, Xpos
    DelayMs 10
  Next
  ,
  ' Now erase the line
  ,
  For Xpos = 0 to 127
    UnPlot 20, Xpos
    DelayMs 10
  Next
Wend
```

See also : LCDRead, LCDWrite, Pixel, Plot. See Print for circuit.

Val

Syntax

Assignment Variable = Val (Array Variable, Modifier)

Overview

Convert a Byte Array or String containing Decimal, Hex, or Binary numeric text into its integer equivalent.

Parameters

Array Variable is a byte array or string containing the alphanumeric digits to convert and terminated by a null (i.e. value 0).

Modifier can be Hex, Dec, or Bin. To convert a Hex string, use the Hex modifier, for Binary, use the Bin modifier, for Decimal use the Dec modifier.

Assignment Variable is a variable that will contain the converted value. Floating point characters and variables cannot be converted, and will be rounded down to the nearest integer value.

Example 1

```
' Convert a string of hexadecimal characters to an integer
Device = 24HJ128GP502
Declare Xtal = 16
Dim String1 as String * 10      ' Create a String
Dim MyWord as Word             ' Create a variable to hold result
DelayMs 100                    ' Wait for things to stabilise
Cls                             ' Clear the LCD
String1 = "12AF"               ' Load the String with Hex ASCII
MyWord = Val(String1,Hex)      ' Convert the String into an integer
Print Hex MyWord               ' Display the integer as Hex
```

Example 2

```
' Convert a string of decimal characters to an integer
Device = 24HJ128GP502
Declare Xtal = 16
Dim String1 as String * 10     ' Create a String
Dim MyWord as Word             ' Create a variable to hold result
DelayMs 100                    ' Wait for things to stabilise
Cls                             ' Clear the LCD
String1 = "1234"               ' Load the String with Decimal ASCII
MyWord = Val(String1,Dec)      ' Convert the String into an integer
Print Dec MyWord               ' Display the integer as Decimal
```

Example 3

```
' Convert a string of binary characters to an integer
Device = 24HJ128GP502
Declare Xtal = 16
Dim String1 as String * 17     ' Create a String
Dim MyWord as Word             ' Create a variable to hold result
DelayMs 100                    ' Wait for things to stabilise
Cls                             ' Clear the LCD
String1 = "1010101010000000"  ' Load the String with Binary ASCII
MyWord = Val(String1,Bin)      ' Convert the String into an integer
Print Bin MyWord               ' Display the integer as Binary
```

Notes.

The **Val** command is not recommended inside an expression, as the results are not predictable. However, the **Val** command can be used within an **If-Then**, **While-Wend**, or **Repeat-Until** construct, but the code produced is not as efficient as using it outside a construct, because the compiler must assume a worst case scenario, and use **Dword** comparisons.

```
Device = 24HJ128GP502
Declare Xtal = 16

Dim String1 as String * 10           ' Create a String
DelayMs 100                          ' Wait for things to stabilise
Cls                                   ' Clear the LCD
String1 = "123"                       ' Load the String with Decimal ASCII
If Val(String1,Hex) = 123 Then        ' Compare the result
    Print At 1,1,Dec Val (String1,Hex)
Else
    Print At 1,1,"Not Equal"
EndIf
```

See also: **Str, Strn, Str\$.**

AddressOf

Syntax

Assignment Variable = **AddressOf** (*Variable or Label*)

Overview

Returns the address of a variable in RAM, or a label in code memory. Commonly known as a pointer.

Parameters

Assignment Variable can be any of the compiler's variable types, and will receive the *variable's* or *label's* address.

Variable or Label can be any variable type used in the BASIC program, or it can be a label name, in which case, it will return the code memory address.

While...Wend

Syntax

While *Condition*

Instructions

Instructions

Wend

OR

While *Condition* { *Instructions* } : **Wend**

OR

While

Instructions

Instructions

Wend

Overview

Execute a block of instructions while a condition is true, unless no condition is placed after **While**, in which case and infinite loop will be created.

Example

```
MyVar = 1
while MyVar <= 10
    Print Dec MyVar, " "
    MyVar = MyVar + 1
wend
```

OR

```
while PORTA.0 = 1 : wend ' Wait for a change on the Port
```

OR

```
MyVar = 1
while
    Print at 1,1, Dec MyVar, " "
    MyVar = MyVar + 1
wend
```

Notes.

While-Wend, repeatedly executes *Instructions* **While** *Condition* is true. When the *Condition* is no longer true, execution continues at the statement following the **Wend**. *Condition* may be any comparison expression. If no condition is placed after **While**, an infinite loop will be created. A no condition **While-Wend** is only valid when both are on a separate line.

See also : If-Then, Repeat-Until, For-Next.

Using the Preprocessor

A preprocessor directive is a non executable statement that informs the compiler how to compile. For example, some microcontroller have certain hardware features that others don't. A preprocessor directive can be used to inform the compiler to add or remove source code, based on that particular devices ability to support that hardware.

It's important to note that the preprocessor works with directives on a line by line basis. It is therefore important to ensure that each directive is on a line of its own. Don't place directives and source code on the same line.

It's also important not to mistake the compiler's preprocessor with the assembler's preprocessor. Any directive that starts with a dollar "\$" is the compiler's preprocessor, and any directive that starts with a hash "#" is the assembler's preprocessor. They cannot be mixed, as each has no knowledge of the other.

Preprocessor directives can be nested in the same way as source code statements. For example:

```
$ifdef MyValue
    $if MyValue = 10
        Symbol CodeConst = 10
    $else
        Symbol CodeConst = 0
    $endif
$endif
```

Preprocessor directives are lines included in the code of the program that are not BASIC language statements but directives for the preprocessor itself. The preprocessor is actually a separate entity to the compiler, and, as the name suggests, pre-processes the BASIC code before the actual compiler sees it. Preprocessor directives are always preceded by a dollar sign "\$".

Preprocessor Directives

To define preprocessor macros the directive **\$define** is used. Its format is:-

\$define *identifier replacement*

When the preprocessor encounters this directive, it replaces any occurrence of *identifier* in the rest of the code by *replacement*. This replacement can be an expression, a statement, a block, or simply anything. The preprocessor does not understand BASIC, it simply replaces any occurrence of *identifier* by *replacement*.

```
$define TableSize 100
Dim Table1[TableSize] as Byte
Dim Table2[TableSize] as Byte
```

After the preprocessor has replaced TableSize, the code becomes equivalent to:-

```
Dim Table1[100] as Byte
Dim Table2[100] as Byte
```

The use of **\$define** as a constant definer is only one aspect of the preprocessor, and **\$define** can also work with parameters to define pseudo function macros. The syntax then is:-

\$define *identifier (parameter list) replacement*

A simple example of a function-like macro is:-

```
$define RadToDeg(x) ((x) * 57.29578)
```

This defines a radians to degrees conversion which can be used as:-

```
Var1 = RadToDeg(34)
```

This is expanded in-place, so the caller does not need to clutter copies of the multiplication constant throughout the code.

Precedence

Note that the example macro RadToDeg(x) given above uses normally unnecessary parentheses both around the argument and around the entire expression. Omitting either of these can lead to unexpected results. For example:-

Macro defined as:

```
$define RadToDeg(x) (x * 57.29578)
```

will expand

```
RadToDeg(a + b)
```

to

```
(a + b * 57.29578)
```

Macro defined as

```
$define RadToDeg(x) (x) * 57.29578
```

will expand

```
1 / RadToDeg(a)
```

to

```
1 / (a) * 57.29578
```

neither of which give the intended result.

Not all replacement tokens can be passed back to an assignment using the equals operator. If this is the case, the code needs to be similar to BASIC Stamp syntax, where the assignment variable is the last parameter:-

```
$define GetMax(x,y,z) If x > y Then z = x : Else : z = y
```

This would replace any occurrence of GetMax followed by three parameter (argument) by the replacement expression, but also replacing each parameter by its identifier, exactly as would be expected of a function.

```
Dim Var1 as Byte  
Dim Var2 as Byte  
Dim Var3 as Byte
```

```
Var1 = 100  
Var2 = 99  
GetMax(Var1, Var2, Var3)
```

The previous would be placed within the BASIC program as:-

```
Dim Var1 as Byte
Dim Var2 as Byte
Dim Var3 as Byte

Var1 = 100
Var2 = 99
If Var1 > Var2 Then Var3 = Var1 : Else : Var3 = Var2
```

Notice that the third parameter “Var3” is loaded with the result.

A macro lasts until it is undefined with the **\$undef** preprocessor directive:-

```
$define TableSize 100
Dim Table1[TableSize] as Byte
$undef TableSize
$define TableSize 200
Dim Table2[TableSize] as Byte
```

This would generate the same code as:-

```
Dim Table1[100] as Byte
Dim Table2[200] as Byte
```

Because preprocessor replacements happen before any BASIC syntax check, macro definitions can be a tricky feature, so be careful. Code that relies heavily on complicated macros may be difficult to understand, since the syntax they expect is, on many occasions, different from the regular expressions programmers expect in Proton24 BASIC.

Preprocessor directives only extend across a single line of code. As soon as a newline character is found (end of line), the preprocessor directive is considered to end. The only way a preprocessor directive can extend through more than one line is by preceding the newline character at the end of the line by a comment character (') followed by a new line. No comment text can follow the comment character. For example:-

```
$define GetMax(x,y,z) '
  If x > y Then      '
    z = x            '
  Else               '
    z = y            '
  EndIf

GetMax(Var1, Var2, Var3)
```

The compiler will see:-

```
If Var1 > Var2 Then
  Var3 = Var1
Else
  Var3 = Var2
EndIf
```

Note that parenthesis is always required around the **\$define** declaration and its use within the program.

If the *replacement* argument is not included within the **\$define** directive, the *identifier* argument will output nothing. However, it can be used as an identifier for conditional code:-

```
$define DoThis  
  
$ifdef DoThis  
    {Rest of Code here}  
$endif
```

\$undef *identifier*

This removes any existing definition of the user macro *identifier*.

\$eval *expression*

In normal operation, the **\$define** directive simply replaces text, however, using the **\$eval** directive allows constant value expressions to be evaluated before replacement within the BASIC code. For example:-

```
$define Expression(Prm1) $eval (Prm1 << 1)
```

The above will evaluate the constant parameter Prm1, shifting it left one position.

```
Var1 = Expression(1)
```

Will be added to the BASIC code as:-

```
Var1 = 2
```

Because 1 shifted left one position is 2.

Several operands are available for use with an expression. These are +, -, *, -, ~, <<, >>, =, >, <, >=, <=, <>, And, Or, Xor.

Conditional Directives (**\$ifdef**, **\$ifndef**, **\$if**, **\$endif**, **\$else** and **\$elseif**)

Conditional directives allow parts of the code to be included or discarded if a certain condition is met.

\$ifdef allows a section of a program to be compiled only if the macro that is specified as the parameter has been defined, no matter what its value is. For example:-

```
$ifdef TableSize  
    Dim Table[TableSize] as Byte  
$endif
```

In the above condition, the line of code *Dim Table[TableSize] as Byte* is only compiled if TableSize was previously defined with **\$define**, independent of its value. If it was not defined, the line will not be included in the program compilation.

\$ifndef serves for the exact opposite of **\$ifdef**. The code between **\$ifndef** and **\$endif** directives is only compiled if the specified identifier has not been previously defined. For example:-

```
$ifndef TableSize  
    $define TableSize 100  
$endif  
Dim Table[TableSize] as Byte
```

In the previous code, when arriving at this piece of code, the `TableSize` directive has not been defined yet. If it already existed it would keep its previous value since the `$define` directive would not be executed.

A valuable use for `$ifdef` is that of a code guard with include files. This allows multiple insertions of a file, but only the first will be used.

A typical code guard looks like:

```
$ifndef Unique Name
    $define Unique Name
    { BASIC Code goes Here }
$endif
```

The logic of the above snippet is that if the include file has not previously been loaded into the program, the `$define Unique Name` will not have been created, thus allowing the inclusion of the code between `$ifndef` and `$endif`. However, if the include file has been previously loaded, the `$define` will have already been created, and the condition will be false, thus not allowing the code to be used.

Unique Name must be unique to each file. Therefore, it is recommended that a derivative of the include file's name is used.

`$if expression`

This directive invokes the arithmetic evaluator and compares the result in order to begin a conditional block. In particular, note that the logical value of *expression* is always true when it cannot be evaluated to a number.

The `$if` directive as well as the `$elseif` directive can use quite complex logic. For example:-

```
$if _device = _24FJ64GA002 or _device = _24FJ128GA002 and _core = 24
    { BASIC Code Here }
$endif
```

There are several built in user defines that will help separate blocks of code. These are:-

- **_device**. This holds the device name, as a string. i.e. `_24FJ64GA002` etc.
- **_type**. This hold the type of PIC24. E, F or H or dsPIC33. F or E:
 - For PIC24E, **_type** will hold the ASCII string `_PIC24E`
 - For PIC24F, **_type** will hold the ASCII string `_PIC24F`
 - For PIC24H, **_type** will hold the ASCII string `_PIC24H`
 - For dsPIC33E, **_type** will hold the ASCII string `_DSPIC33E`
 - For dsPIC33F, **_type** will hold the ASCII string `_DSPIC33F`
- **_core**. This holds the device's core. i.e. 24 or 33
- **_ram**. This holds the amount of RAM contained in the device (in bytes).
- **_code**. This holds the amount of flash memory in the device. In *bytes*.
- **_eeprom**. This holds the amount of eeprom memory the device contains.
- **_ports**. This holds the amount of I/O ports that the device has.
- **_adc**. This holds the amount of ADC channels the device has.
- **_usart**. This holds the amount of USARTS the device has. i.e. 0, 1, 2, 3, or 4

The values for the user defines are taken from the compiler's `.def` files, and are only available if the compiler's `Device` directive is included within the BASIC program.

Also within the compiler's .def files are all the device's SFRs (Special Function Registers) and SFR bit names. The SFR names are preceded by an underscore so they do not clash with the assembler's SFR names. For example:

```
WREG0 is _WREG0
WREG12 is _WREG12
```

The SFR names are useful for compiling a piece of code only if that particular SFR is present in the device being used:

```
$ifdef _T1CON
  { BASIC Code Here }
$endif
```

The SFR bit names are extremely useful within the BASIC program because they circumvent any differences in the device's makeup. For example, in order to access a device's Carry flag, use: SRbits_C

All the bitnames follow the same rule, where the SFR name is first, followed by the text "bits_", followed by the bit name. Below are a few examples:

```
T1CONbits_TCS
T1CONbits_TSYNC
T1CONbits_TGATE
T1CONbits_TSIDL
T1CONbits_TON
T1CONbits_TCKPS0
T1CONbits_TCKPS1
```

\$else

This toggles the logical value of the current conditional block. What follows is evaluated if the preceding condition was not met.

\$endif

This ends a conditional block started by the **\$if**, **\$ifdef** or **\$ifndef** directives.

\$elseif *expression*

This directive can be used to avoid nested **\$if** conditions. **\$if..\$elseif..\$endif** is equivalent to **\$if..\$else \$if ..\$endif \$endif**.

The **\$if**, **\$else** and **\$elseif** directives serve to specify some condition to be met in order for the portion of code they surround to be compiled. The condition that follows **\$if** or **\$elseif** can only evaluate constant expressions, including macro expressions. For example:-

```
$if TableSize > 200
    $undef TableSize
    $define TableSize 200

$elseif TableSize < 50
    $undef TableSize
    $define TableSize 50

$else
    $undef TableSize
    $define TableSize 100
$endif
```

```
Dim Table[TableSize] as Byte
```

Notice how the whole structure of **\$if**, **\$elseif** and **\$else** chained directives ends with **\$endif**.

The behaviour of **\$ifdef** and **\$ifndef** can also be achieved by using the special built-in user directive **_defined** and **!_defined** respectively, in any **\$if** or **\$elseif** condition. These allow more flexibility than **\$ifdef** and **\$ifndef**. For example:-

```
$if _defined (MyDefine) and _defined (AnotherDefine)
    { BASIC Code Here }
$endif
```

The argument for the **_defined** user directive must be surrounded by parenthesis. The preceding character "!" means "not".

\$error message

This directive causes an error message with the current filename and line number. Subsequent processing of the code is then aborted.

```
$error Error Message Here
```

Proton IDE Overview

The Proton IDE is a professional and powerful Integrated Development Environment (IDE) designed specifically for the Proton24 compiler. It is designed to accelerate product development in a comfortable user friendly environment without compromising performance, flexibility or control.

Code Explorer

Allows quick navigation through the program code and device SFRs (Special Function Registers) .

Compiler Results

Provides information about the device used, the amount of code and data used, the version number of the project and also date and time. You can also use the results window to jump to compilation errors.

Programmer Integration

The IDE enables you to start your preferred programming software from within the development environment . This enables you to compile and then program your microcontroller with just a few mouse clicks (or keyboard strokes, if you prefer).

Serial Communicator

A simple to use utility which enables you to transmit and receive data via a serial cable connected to your PC and development board. The easy to use configuration window allows you to select port number, Baud rate, parity, byte size and number of stop bits. Alternatively, you can use Serial Communicator favourites to quickly load pre-configured connection settings.

Plugin Architecture

The Proton IDE has been designed with flexibility in mind with support for IDE plugins.

Supported Operating Systems

Windows XP, Windows 7, Windows 8 , Windows 10 (32-bit or 64-bit)

Hardware Requirements

At least a 1 GHz Processor

At least 1 GB of RAM

At least 40 GB of hard drive space for the O/S and applications etc.

Menu Bar

File Menu

- **New** - Creates a new document. A header is automatically generated, showing information such as author, copyright and date. To toggle this feature on or off, or edit the header properties, you should select editor options.
- **Open** - Displays a open dialog box, enabling you to load a document into the Proton IDE. If the document is already open, then the document is made the active editor page.
- **Save** - Saves a document to disk. This button is normally disabled unless the document has been changed. If the document is 'untitled', a save as dialog is invoked. A save as dialog is also invoked if the document you are trying to save is marked as read only.
- **Save As** - Displays a save as dialog, enabling you to name and save a document to disk.
- **Close** - Closes the currently active document.
- **Close All** - Closes all editor documents and then creates a new editor document.
- **Reopen** - Displays a list of Most Recently Used (MRU) documents.
- **Print Setup** - Displays a print setup dialog.
- **Print Preview** - Displays a print preview window.
- **Print** - Prints the currently active editor page.
- **Exit** - Enables you to exit the Proton IDE.

Edit Menu

- **Undo** - Cancels any changes made to the currently active document page.
- **Redo** - Reverse an undo command.
- **Cut** - Cuts any selected text from the active document page and places it into the clipboard. This option is disabled if no text has been selected. Clipboard data is placed as both plain text and RTF.
- **Copy** - Copies any selected text from the active document page and places it into the clipboard. This option is disabled if no text has been selected. Clipboard data is placed as both plain text and RTF.
- **Paste** - Paste the contents of the clipboard into the active document page. This option is disabled if the clipboard does not contain any suitable text.
- **Delete** - Deletes any selected text. This option is disabled if no text has been selected.
- **Select All** - Selects the entire text in the active document page.
- **Change Case** - Allows you to change the case of a selected block of text.

- **Find** - Displays a find dialog.
- **Replace** - Displays a find and replace dialog.
- **Find Next** - Automatically searches for the next occurrence of a word. If no search word has been selected, then the word at the current cursor position is used. You can also select a whole phrase to be used as a search term. If the editor is still unable to identify a search word, a find dialog is displayed.

View Menu

- **Results** - Display or hide the results window.
- **Code Explorer** - Display or hide the code explorer window.
- **Loader** - Displays the MicroCode Loader application.
- **Loader Options** - Displays the MicroCode Loader options dialog.
- **Compile and Program Options** - Displays the compile and program options dialog.
- **Editor Options** - Displays the application editor options dialog.
- **Toolbars** - Display or hide the main, edit and compile and program toolbars. You can also toggle the toolbar icon size.
- **Plugin** - Display a drop down list of available IDE plugins.
- **Online Updates** - Executes the IDE online update process, which checks online and installs the latest IDE updates.

Help Menu

- **Help Topics** - Displays the help file section for the toolbar.
- **Online Forum** - Opens your default web browser and connects to the online Proton24 Plus developer forum.
- **About** - Display about dialog, giving both the Proton IDE and Proton24 compiler version numbers.

Main Toolbar



New

Creates a new document. A header is automatically generated, showing information such as author, copyright and date. To toggle this feature on or off, or edit the header properties, you should select the editor options dialog from the main menu.



Open

Displays a open dialog box, enabling you to load a document into the Proton IDE. If the document is already open, then the document is made the active editor page.



Save

Saves a document to disk. This button is normally disabled unless the document has been changed. If the document is 'untitled', a save as dialog is invoked. A save as dialog is also invoked if the document you are trying to save is marked as read only.



Cut

Cuts any selected text from the active document page and places it into the clipboard. This option is disabled if no text has been selected. Clipboard data is placed as both plain text and RTF.



Copy

Copies any selected text from the active document page and places it into the clipboard. This option is disabled if no text has been selected. Clipboard data is placed as both plain text and RTF.



Paste

Paste the contents of the clipboard into the active document page. This option is disabled if the clipboard does not contain any suitable text.



Undo

Cancels any changes made to the currently active document page.



Redo

Reverse an undo command.



Print

Prints the currently active editor page.

Edit Toolbar



Find

Displays a find dialog.



Find and Replace

Displays a find and replace dialog.



Indent

Shifts all selected lines to the next tab stop. If multiple lines are not selected, a single line is moved from the current cursor position. All lines in the selection (or cursor position) are moved the same number of spaces to retain the same relative indentation within the selected block. You can change the tab width from the editor options dialog.



Outdent

Shifts all selected lines to the previous tab stop. If multiple lines are not selected, a single line is moved from the current cursor position. All lines in the selection (or cursor position) are moved the same number of spaces to retain the same relative indentation within the selected block. You can change the tab width from the editor options dialog.

Block Comment

Adds the comment character to each line of a selected block of text. If multiple lines are not selected, a single comment is added to the start of the line containing the cursor.

Block Uncomment

Removes the comment character from each line of a selected block of text. If multiple lines are not selected, a single comment is removed from the start of the line containing the cursor.

Compile and Program Toolbar

Compile

Pressing this button, or F9, will compile the currently active editor page. The compile button will generate a *.hex file, which you then have to manually program into your microcontroller. Pressing the compile button will automatically save all open files to disk. This is to ensure that the compiler is passed an up to date copy of the file(s) your are editing.

Compile and Program

Pressing this button, or F10, will compile the currently active editor page. Pressing the compile and program button will automatically save all open files to disk. This is to ensure that the compiler is passed an up to date copy of the file(s) your are editing.

Unlike the compile button, the Proton IDE will then automatically invoke a user selectable application and pass the compiler output to it. The target application is normally a device programmer. This enables you to program the generated *.hex file into the microcontroller. Alternatively, the compiler output can be sent to an IDE Plugin. You can select a different programmer or Plugin by pressing the small down arrow, located to the right of the compile and program button...

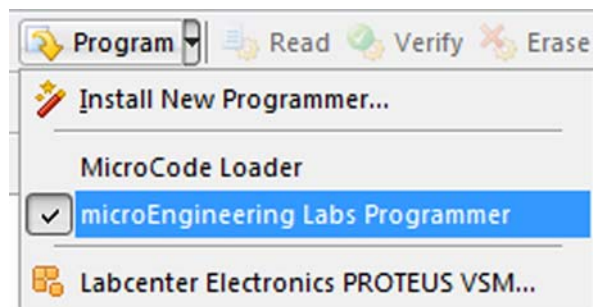

In the above example, melab's USB programmer has been selected as the default device programmer. The compile and program drop down menu also enables you to install new programming software. Just select the 'Install New Programmer...' option to invoke the programmer configuration wizard. Once a program has been compiled, you can use F11 to automatically start your programming software or plugin. You do not have to re-compile, unless of course your program has been changed.

Code Explorer

The code explorer enables you to easily navigate your program code. The code explorer tree displays your currently selected processor, include files, declares, constants, variables, alias and modifiers, labels, macros and data labels.

Device Node

The device node is the first node in the explorer tree. It displays your currently selected processor type. For example, if your program has the declaration: -



```
Device = 24HJ128GP502
```

then the name of the device node will be 24HJ128GP502. You don't need to explicitly give the device name in your program for it to be displayed in the explorer. For example, you may have an include file with the device type already declared. The code explorer looks at all include files to determine the device type. The last device declaration encountered is the one used in the explorer window. If you expand the device node, then all Special Function Registers (SFRs) belonging to the selected device are displayed in the explorer tree.

Include File Node

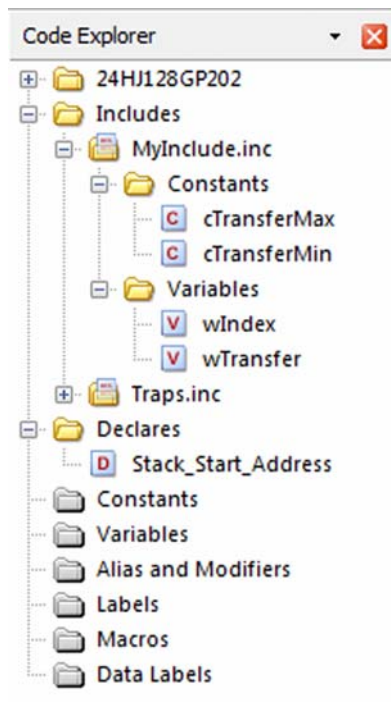
When you click on an include file, the IDE will automatically open that file for viewing and editing. Alternatively, you can just explore the contents of the include file without having to open it. To do this, just click on the  icon and expand the node. For example: -



In the above example, clicking on the  icon for MyInclude.inc has expanded the node to reveal its contents. It can now be seen that MyInclude.inc has two constant declarations called cTransferMax and cTransferMin and also two variables called wIndex and wTransfer. The include file also contains another include file called Traps.inc. Again, by clicking the  icon, the contents of the Traps.inc file can be seen, without opening the file itself. Clicking on a declaration name will open the include file and automatically jump to the line number. For example, if you were to click on cTransferMax, the include file MyInclude.inc would be opened and the declaration cTransferMax would be marked in the IDE editor window.

When using the code explorer with include files, you can use the explorer history buttons to go backwards or forwards. The explorer history buttons are normally located to the left of the main editors file select tabs,

- ← History back button
- History forward button

Additional Nodes

Declares, constants, variables, alias and modifiers, labels, macros and data label explorer nodes work in much the same way. Clicking on any of these nodes will take you to its declaration. If you want to find the next occurrence of a declaration, you should enable automatically select variable on code explorer click from *View...Editor Options*.

Selecting this option will load the search name into the 'find dialog' search buffer. You then just need to press F3 to search for the next occurrence of the declaration in your program. To sort the explorer nodes, right click on the code explorer and check the Sort Nodes option.

Results View

The results view performs two main tasks. These are (a) display a list of error messages, should either compilation or assembly fail and (b) provide a summary on compilation success.

Compilation Success View

By default, a successful compile will display the results success view. This provides information about the device used, the amount of code and RAM used, the version number of the project and also date and time. Note that RAM usage also includes the microcontroller's stack size.



If you don't want to see full summary information after a successful compile, select *View...Editor Options* from the IDE main menu and uncheck display full summary after successful compile. The number of program bytes and the number of data bytes used will still be displayed in the IDE status bar.

Version Numbers

The version number is automatically incremented after a successful build. Version numbers are displayed as major, minor, release and build. Each number will rollover if it reaches 256. For example, if your version number is 1.0.0.255 and you compile again, the number displayed will be 1.0.1.0. You might want to start your version information at a particular number. For example 1.0.0.0. To do this, click on the version number in the results window to invoke the version information dialog. You can then set the version number to any start value. Automatic incrementing will then start from the number you have specified. To disable version numbering, click on the version number in the results window to invoke the version information dialog and then uncheck enable version information.

Date and Time

Date and time information is extracted from the generated *.hex file and is always displayed in the results view.

Success - With Warnings!

A compile is considered successful if it generates a *.hex file. However, you may have generated a number of warning or reminder messages during compilation. Because you should not normally ignore warning messages, the IDE will always display the error view, rather than the success view, if warnings have been generated.

To toggle between these different views, you can do one of the following click anywhere on the IDE status bar right click on the results window and select the Toggle View option.

Compilation Error View

If your program generates warning or error messages, the error view is always displayed.

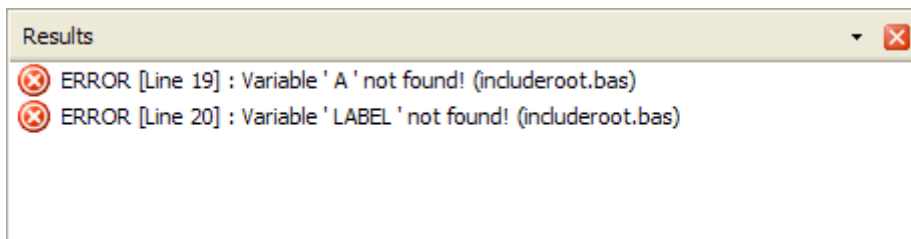

Clicking on each error or warning message will automatically highlight the offending line in the main editor window. If the error or warning has occurred in an include file, the file will be opened and the line highlighted. By default, the IDE will automatically highlight the first error line found. To disable this feature, select *View...Editor Options* from the IDE main menu and uncheck automatically jump to first compilation error. At the time of writing, some compiler errors do not have line numbers bound to them. Under these circumstances, the Proton IDE will be unable to automatically jump to the selected line.

Occasionally, the compiler will generate a valid Asm file but warnings or errors are generated during assembly. The IDE will display all assembler warnings or error messages in the error view, but you will be unable to automatically jump to a selected line.

Editor Options

The editor options dialog enables you to configure and control many of the Proton IDE features. The window is composed of four main areas, which are accessed by selecting the General, Highlighter, Program Header and Online Updating tabs.

Show Line Numbers in Left Gutter

Display line numbers in the editors left hand side gutter. If enabled, the gutter width is increased in size to accommodate a five digit line number.

Show Right Gutter

Displays a line to the right of the main editor. You can also set the distance from the left margin (in characters). This feature can be useful for aligning your program comments.

Use Smart Tabs

Normally, pressing the tab key will advance the cursor by a set number of characters. With smart tabs enabled, the cursor will move to a position along the current line which depends on the text on the previous line. Can be useful for aligning code blocks.

Convert Tabs to Spaces

When the tab key is pressed, the editor will normally insert a tab control character, whose size will depend on the value shown in the width edit box (the default is four spaces). If you then press the backspace key, the whole tab is deleted (that is, the cursor will move back four spaces). If convert tabs to spaces is enabled, the tab control character is replaced by the space control character (multiplied by the number shown in the width edit box). Pressing the backspace key will therefore only move the cursor back by one space. Please note that internally, the editor does not use hard tabs, even if convert tabs to spaces is unchecked.

Automatically Indent

When the carriage return key is pressed in the editor window, automatically indent will advance the cursor to a position just below the first word occurrence of the previous line. When this feature is unchecked, the cursor just moves to the beginning of the next line.

Show Parameter Hints

If this option is enabled, small prompts are displayed in the main editor window when a particular compiler keyword is recognised. For example,

DELAYMS

DELAYMS *Value or Variable or Expression*

Parameter hints are automatically hidden when the first parameter character is typed. To view the hint again, press F1.

Open Last File(s) When Application Starts

When checked, the documents that were open when the Proton IDE was closed are automatically loaded again when the application is restarted.

Display Full Filename Path in Application Title Bar

By default, The IDE only displays the document filename in the main application title bar (that is, no path information is included). Check display full pathname if you would like to display additional path information in the main title bar.

Prompt if File Reload Needed

The IDE automatically checks to see if a file time stamp has changed. If it has (for example, and external program has modified the source code) then a dialog box is displayed asking if the file should be reloaded. If prompt on file reload is unchecked, the file is automatically reloaded without any prompting.

Automatically Select Variable on Code Explorer Click

By default, clicking on a link in the code explorer window will take you to the part of your program where a declaration has been made. Selecting this option will load the search name into the 'find dialog' search buffer. You then just need to press F3 to search for the next occurrence of the declaration in your program.

Automatically Jump to First Compilation Error

When this is enabled, The IDE will automatically jump to the first error line, assuming any errors are generated during compilation.

Automatically Change Identifiers to Match Declaration

When checked, this option will automatically change the identifier being typed to match that of the actual declaration. For example, if you have the following declaration,

```
Dim MyIndex as Word
```

and you type 'myindex' in the editor window, The IDE will automatically change 'myindex' to 'MyIndex'. Identifiers are automatically changed to match the declaration even if the declaration is made in an include file.

Please note that the actual text is not physically changed, it just changes the way it is displayed in the editor window. For example, if you save the above example and load it into wordpad or another text editor, it will still show as 'myindex'. If you print the document, the identifier will be shown as 'MyIndex'. If you copy and paste into another document, the identifier will be shown as 'MyIndex', if the target application supports formatted text (for example Microsoft Word). In short, this feature is very useful for printing, copying and making you programs look consistent throughout.

Clear Undo History After Successful Compile

If checked, a successful compilation will clear the undo history buffer. A history buffer takes up system resources, especially if many documents are open at the same time. It's a good idea to have this feature enabled if you plan to work on many documents at the same time.

Display Full Summary After Successful Compile

If checked, a successful compilation will display a full summary in the results window. Disabling this option will still give a short summary in the IDE status bar, but the results window will not be displayed.

Default Source Folder

The IDE will automatically go to this folder when you invoke the file open or save as dialogs. To disable this feature, uncheck the 'Enabled' option, shown directly below the default source folder.

Highlighter Options

Item Properties

The syntax highlighter tab lets you change the colour and attributes (for example, bold and italic) of the following items: -

- Comment
- Device Name
- Identifier
- Keyword (Asm)
- Keyword (Declare)
- Keyword (Important)
- Keyword (Macro Parameter)
- Keyword (Proton24)
- Keyword (User)
- Number
- Number (Binary)
- Number (Hex)
- SFR
- SFR (Bitname)
- String
- Symbol
- Preprocessor

The point size is ranged between 6pt to 16pt and is global. That is, you cannot have different point sizes for individual items.

Reserved Word Formatting

This option enables you to set how The IDE displays keywords. Options include: -

Database Default - the IDE will display the keyword as declared in the applications keyword database.

Uppercase - the IDE will display the keyword in uppercase.

Lowercase - the IDE will display the keyword in lowercase.

As Typed - the IDE will display the keyword as you have typed it.

Please note that the actual keyword text is not physically changed, it just changes the way it is displayed in the editor window. For example, if you save your document and load it into wordpad or another text editor, the keyword text will be displayed as you typed it. If you print the document, the keyword will be formatted. If you copy and paste into another document, the keyword will be formatted, if the target application supports formatted text (for example Microsoft Word).

Header options allows you to change the author and copyright name that is placed in a header when a new document is created. For example: -

```
*****  
' * Name      : Untitled.bas                               *  
' * Author   : J.R Hartley                               *  
' * Notice   : Copyright (c) 2013 MyCompany              *  
' *          : All Rights Reserved                       *  
' * Date     : 19/01/13                                  *  
' * Version  : 1.0                                       *  
' * Notes    :                                           *  
' *          :                                           *  
' *          :                                           *  
*****
```

If you do not want to use this feature, simply deselect the enable check box.

Compile and Program Options

Compiler Tab

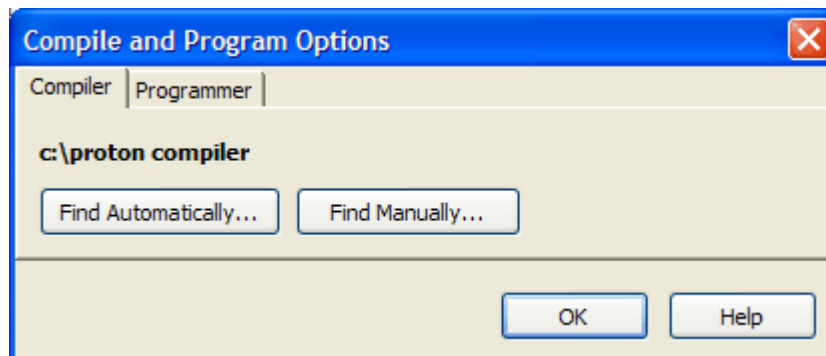

You can get the IDE to locate a compiler directory automatically by clicking on the find automatically button. The auto-search feature will stop when a compiler is found.

Alternatively, you can select the directory manually by selecting the find manually button. The auto-search feature will search for a compiler and if one is found, the search is stopped and the path pointing to the compiler is updated. If you have multiple versions of a compiler installed on your system, use the find manually button. This ensures the correct compiler is used by the IDE.

Programmer Tab

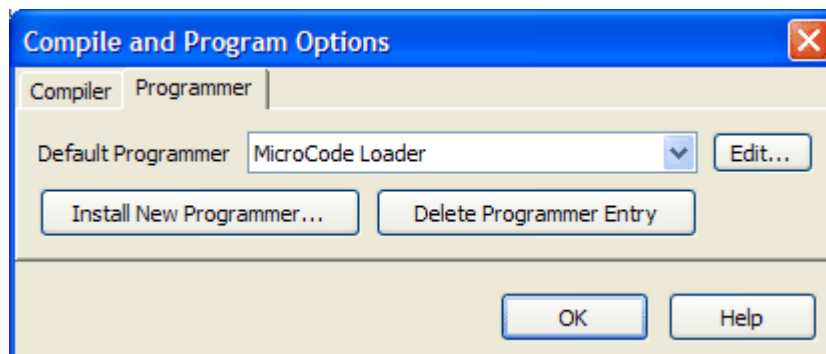

Use the programmer tab to install a new programmer, delete a programmer entry or edit the currently selected programmer. Pressing the Install New Programmer button will invoke the install new programmer wizard. The Edit button will invoke the install new programmer wizard in custom configuration mode.

Installing a Programmer

The IDE enables you to start your preferred programming software from within the development environment . This enables you to compile and then program your microcontroller with just a few mouse clicks (or keyboard strokes, if you prefer). The first thing you need to do is tell the IDE which programmer you are using. Select View...Options from the main menu bar, then select the Programmer tab. Next, select the Add New Programmer button. This will open the install new programmer wizard.

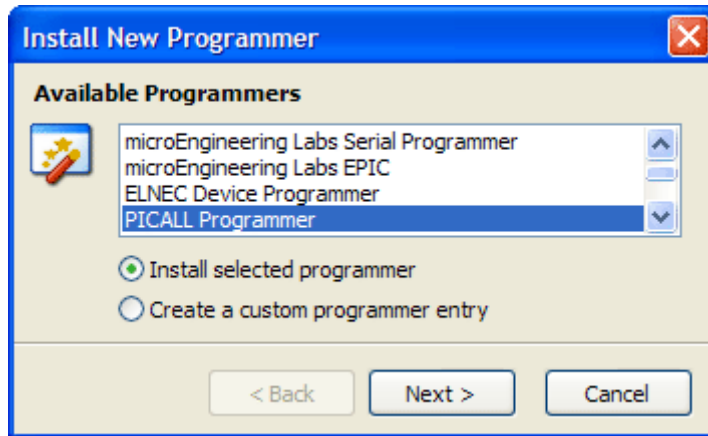

Select the programmer you want the IDE to use, then choose the Next button. The IDE will now search your computer until it locates the required executable. If your programmer is not in the list, you will need to create a custom programmer entry.

Your programmer is now ready for use. When you press the Compile and Program button on the main toolbar, your program is compiled and the programmer software started. The *.hex file-name and target device is automatically set in the programming software (if this feature is supported), ready for you to program your microcontroller.

You can select a different programmer, or install another programmer, by pressing the small down arrow, located to the right of the compile and program button, as shown below

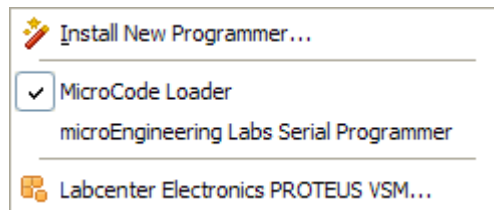

Creating a custom Programmer Entry

In most cases, the IDE has a set of pre-configured programmers available for use. However, if you use a programmer not included in this list, you will need to add a custom programmer entry. Select View...Options from the main menu bar, then select the Programmer tab. Next, select the Add New Programmer button. This will open the install new programmer wizard. You then need to select 'create a custom programmer entry', as shown below

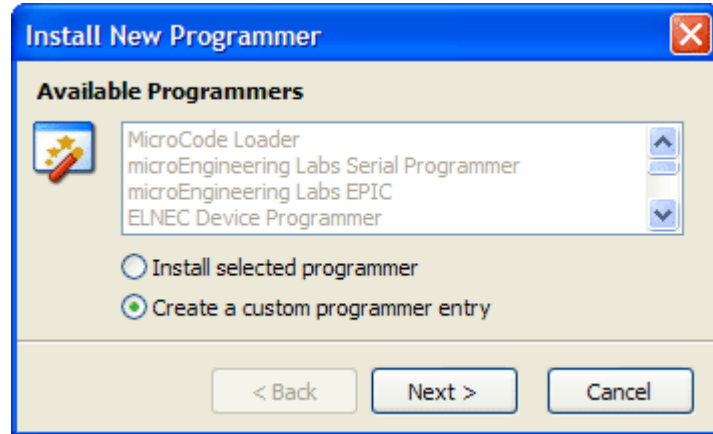

Select Display Name

The next screen asks you to enter the display name. This is the name that will be displayed in any programmer related drop down boxes. The IDE enables you to add and configure multiple programmers. You can easily switch from different types of programmer from the compile and program button, located on the main editor toolbar. The multiple programmer feature means you do not have to keep reconfiguring your system when you switch programmers. The IDE will remember the settings for you. In the example below, the display name will be 'My New Programmer'.

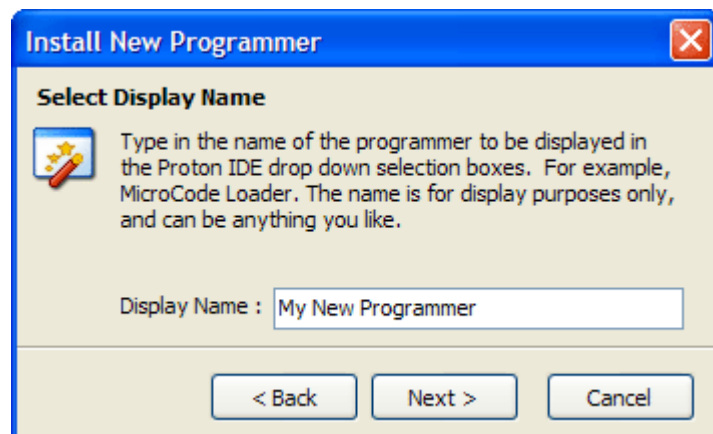

Select Programmer Executable

The next screen asks for the programmer executable name. You do not have to give the full path, just the name of the executable name will do.

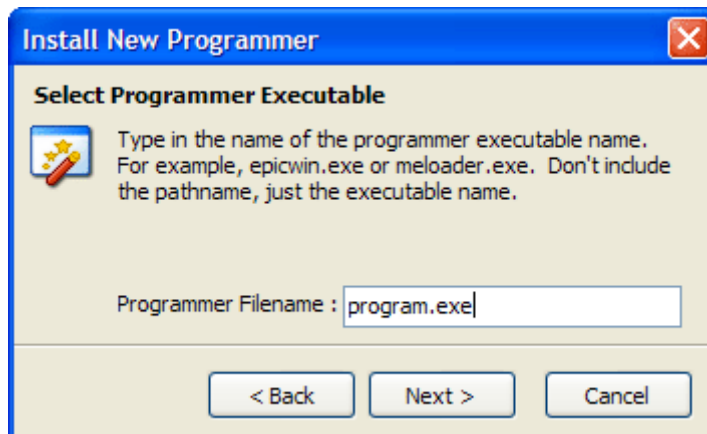

Select Programmer Path

The next screen is the path to the programmer executable. You can let the IDE find it automatically, or you can select it manually.

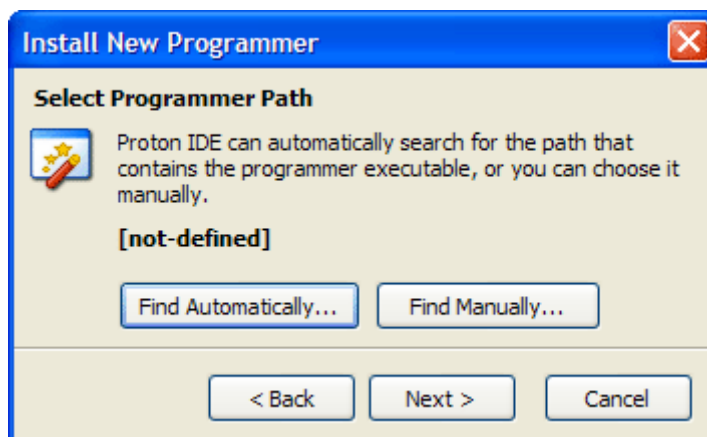

Select Parameters

The final screen is used to set the parameters that will be passed to your programmer. Some programmers, for example, EPICWin™ allows you to pass the device name and hex filename. The IDE enables you to 'bind' the currently selected device and *.hex file you are working on.

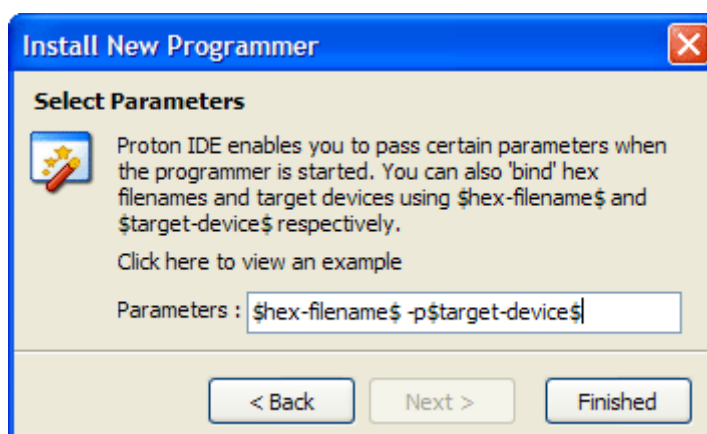

For example, if you are compiling 'blink.bas' in the IDE using a 24FJ64GA002, you would want to pass the 'blink.hex' file to the programmer and also the name of the microcontroller you intend to program. Here is the EPICWin™ example: -

```
-pPIC$target-device$ $hex-filename$
```

When EPICWin™ is started, the device name and hex filename are 'bound' to \$target-device\$ and \$hex-filename\$ respectively. In the 'blink.bas' example, the actual parameter passed to the programmer would be: -

```
-p24FJ64GA002 blink.hex
```

Parameter Summary

Parameter	Description
\$target-device\$	Microcontroller name
\$hex-filename\$	Hex filename and path, DOS 8.3 format
\$long-hex-filename\$	Hex filename and path
\$asm-filename\$	Asm filename and path, DOS 8.3 format
\$long-asm-filename\$	Asm filename and path

IDE Plugins

The Proton IDE has been designed with flexibility in mind. Plugins enable the functionality of the IDE to be extended by through additional third party software, which can be integrated into the development environment. Proton IDE comes with a default set of plugins which you can use straight away. These are: -

- ASCII Table
- Assembler
- Hex View
- Serial Communicator
- Labcenter Electronics Proteus VSM

To access a plugin, select the plugin icon just above the main editor window. A drop down list of available plugins will then be displayed. Plugins can also be selected from the main menu, or by right clicking on the main editor window.

Plugin Developer Notes

The plugin architecture has been designed to make writing third party plugins very easy, using the development environment of your choice (for example Visual BASIC, C++ or Borland Delphi). This architecture is currently evolving and is therefore publicly undocumented until all of the protocols have been finalised. As soon as the protocol details have been finalised, this documentation will be made public. For more information, please feel free to contact us.

ASCII Table

The American Standard Code for Information Interchange (ASCII) is a set of numerical codes, with each code representing a single character, for example, 'a' or '\$'.

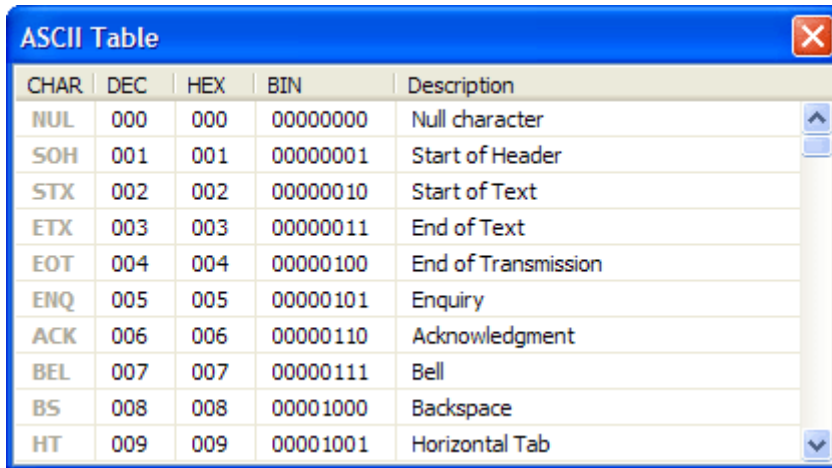

CHAR	DEC	HEX	BIN	Description
NUL	000	000	00000000	Null character
SOH	001	001	00000001	Start of Header
STX	002	002	00000010	Start of Text
ETX	003	003	00000011	End of Text
EOT	004	004	00000100	End of Transmission
ENQ	005	005	00000101	Enquiry
ACK	006	006	00000110	Acknowledgment
BEL	007	007	00000111	Bell
BS	008	008	00001000	Backspace
HT	009	009	00001001	Horizontal Tab

The ASCII table plugin enables you to view these codes in either decimal, hexadecimal or binary. The first 32 codes (0..31) are often referred to as non-printing characters, and are displayed as grey text.

Hex View

The Hex view plugin enables you to view program code and EEPROM data for 14 and 16 core devices.

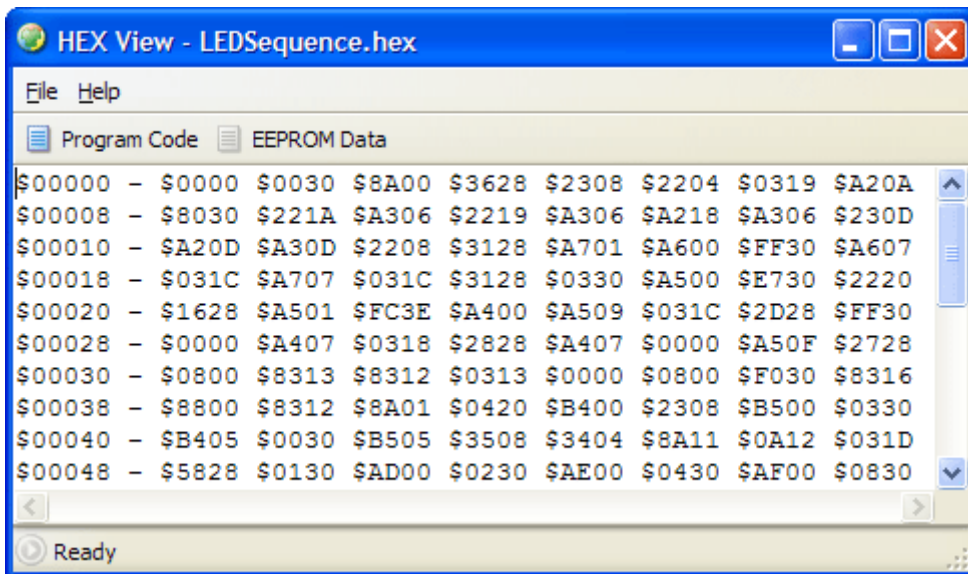

The Hex View window is automatically updated after a successful compile, or if you switch program tabs in the IDE. By default, the Hex view window remains on top of the main IDE window. To disable this feature, right click on the Hex View window and uncheck the Stay on Top option.

Assembler Window

The Assembler plugin allows you to view and modify the *.asm file generated by the compiler. Using the Assembler window to modify the generated *.asm file is not really recommended, unless you have some experience using assembler.

Assembler Menu Bar

File Menu

New - Creates a new document. A header is automatically generated, showing information such as author, copyright and date.

- **Open** - Displays a open dialog box, enabling you to load a document into the Assembler plugin. If the document is already open, then the document is made the active editor page.
- **Save** - Saves a document to disk. This button is normally disabled unless the document has been changed. If the document is 'untitled', a save as dialog is invoked. A save as dialog is also invoked if the document you are trying to save is marked as read only.
- **Save As** - Displays a save as dialog, enabling you to name and save a document to disk.
- **Close** - Closes the currently active document.
- **Close All** - Closes all editor documents and then creates a new editor document.
- **Reopen** - Displays a list of Most Recently Used (MRU) documents.
- **Print Setup** - Displays a print setup dialog.
- **Print** - Prints the currently active editor page.
- **Exit** - Enables you to exit the Assembler plugin.

Edit Menu

- **Undo** - Cancels any changes made to the currently active document page.
- **Redo** - Reverse an undo command.
- **Cut** - Cuts any selected text from the active document page and places it into the clipboard.
- **Copy** - Copies any selected text from the active document page and places it into the clipboard.
- **Paste** - Paste the contents of the clipboard into the active document page. This option is disabled if the clipboard does not contain any suitable text.
- **Delete** - Deletes any selected text. This option is disabled if no text has been selected.
- **Select All** - Selects the entire text in the active document page.

- **Find** - Displays a find dialog.
- **Replace** - Displays a find and replace dialog.
- **Find Next** - Automatically searches for the next occurrence of a word. If no search word has been selected, then the word at the current cursor position is used. You can also select a whole phrase to be used as a search term. If the editor is still unable to identify a search word, a find dialog is displayed.

View Menu

- **Options** - Displays the application editor options dialog.
- **Toolbars** - Display or hide the main and assemble and program toolbars. You can also toggle the toolbar icon size.

Help Menu

- **Help Topics** - Displays the IDE help file.
- **About** - Display about dialog, giving the Assembler plugin version number.

Assembler Main Toolbar



New

Creates a new document. A header is automatically generated, showing information such as author, copyright and date.



Open

Displays a open dialog box, enabling you to load a document into the Assembler plugin. If the document is already open, then the document is made the active editor page.



Save

Saves a document to disk. This button is normally disabled unless the document has been changed. If the document is 'untitled', a save as dialog is invoked. A save as dialog is also invoked if the document you are trying to save is marked as read only.



Cut

Cuts any selected text from the active document page and places it into the clipboard. This option is disabled if no text has been selected.



Copy

Copies any selected text from the active document page and places it into the clipboard. This option is disabled if no text has been selected.



Paste

Paste the contents of the clipboard into the active document page. This option is disabled if the clipboard does not contain any suitable text.



Undo

Cancels any changes made to the currently active document page.



Redo

Reverse an undo command.

Assembler Editor Options

Show Line Numbers in Left Gutter

Display line numbers in the editors left hand side gutter. If enabled, the gutter width is increased in size to accommodate a five digit line number.

Show Right Gutter

Displays a line to the right of the main editor. You can also set the distance from the left margin (in characters). This feature can be useful for aligning your program comments.

Use Smart Tabs

Normally, pressing the tab key will advance the cursor by a set number of characters. With smart tabs enabled, the cursor will move to a position along the current line which depends on the text on the previous line. Can be useful for aligning code blocks.

Convert Tabs to Spaces

When the tab key is pressed, the editor will normally insert a tab control character, whose size will depend on the value shown in the width edit box (the default is four spaces). If you then press the backspace key, the whole tab is deleted (that is, the cursor will move back four spaces). If convert tabs to spaces is enabled, the tab control character is replaced by the space control character (multiplied by the number shown in the width edit box). Pressing the backspace key will therefore only move the cursor back by one space. Please note that internally, the editor does not use hard tabs, even if convert tabs to spaces is unchecked.

Automatically Indent

When the carriage return key is pressed in the editor window, automatically indent will advance the cursor to a position just below the first word occurrence of the previous line. When this feature is unchecked, the cursor just moves to the beginning of the next line.

Open Last File(s) When Application Starts

When checked, the documents that were open when the Assembler plugin was closed are automatically loaded again when the application is restarted.

Display Full Filename Path in Application Title Bar

By default, the Assembler plugin only displays the document filename in the main application title bar (that is, no path information is included). Check display full pathname if you would like to display additional path information in the main title bar.

Prompt if File Reload Needed

The Assembler plugin automatically checks to see if a file time stamp has changed. If it has (for example, and external program has modified the source code) then a dialog box is displayed asking if the file should be reloaded. If prompt on file reload is unchecked, the file is automatically reloaded without any prompting.

Automatically Jump to First Compilation Error

When this is enabled, the Assembler plugin will automatically jump to the first error line, assuming any errors are generated during compilation.

Clear Undo History After Successful Compile

If checked, a successful compilation will clear the undo history buffer. A history buffer takes up system resources, especially if many documents are open at the same time. It's a good idea to have this feature enabled if you plan to work on many documents at the same time.

Default Source Folder

The Assembler plugin will automatically go to this folder when you invoke the file open or save as dialogs. To disable this feature, uncheck the 'Enabled' option, shown directly below the default source folder.

Serial Communicator

The Serial Communicator plugin is a simple to use utility which enables you to transmit and receive data via a serial cable connected to your PC and development board. The easy to use configuration window allows you to select port number, Baud rate, parity, byte size and number of stop bits. Alternatively, you can use Serial Communicator favourites to quickly load pre-configured connection settings.

Menu options

File Menu

- **Clear** - Clears the contents of either the transmit or receive window.
- **Open** - Displays a open dialog box, enabling you to load data into the transmit window.
- **Save As** - Displays a save as dialog, enabling you to name and save the contents of the receive window.
- **Exit** - Enables you to exit the Serial Communicator software.

Edit Menu

- **Undo** - Cancels any changes made to either the transmit or receive window.
- **Cut** - Cuts any selected text from either the transmit or receive window.
- **Copy** - Copies any selected text from either the transmit or receive window.
- **Paste** - Paste the contents of the clipboard into either the transmit or receive window. This option is disabled if the clipboard does not contain any suitable text.
- **Delete** - Deletes any selected text. This option is disabled if no text has been selected.

View Menu

- **Configuration Window** - Display or hide the configuration window.
- **Toolbars** - Display small or large toolbar icons.

Help Menu

- **Help Topics** - Displays the serial communicator help file.
- **About** - Display about dialog, giving software version information.

Serial Communicator Main Toolbar



Clear

Clears the contents of either the transmit or receive window.



Open

Displays a open dialog box, enabling you to load data into the transmit window.



Save As

Displays a save as dialog, enabling you to name and save the contents of the receive window.



Cut

Cuts any selected text from either the transmit or receive window.



Copy

Copies any selected text from either the transmit or receive window.



Paste

Paste the contents of the clipboard into either the transmit or receive window. This option is disabled if the clipboard does not contain any suitable text.



Connect

Connects the Serial Communicator software to an available serial port. Before connecting, you should ensure that your communication options have been configured correctly using the configuration window.



Disconnect

Disconnect the Serial Communicator from a serial port.

Configuration

The configuration window is used to select the COM port you want to connect to and also set the correct communications protocols.

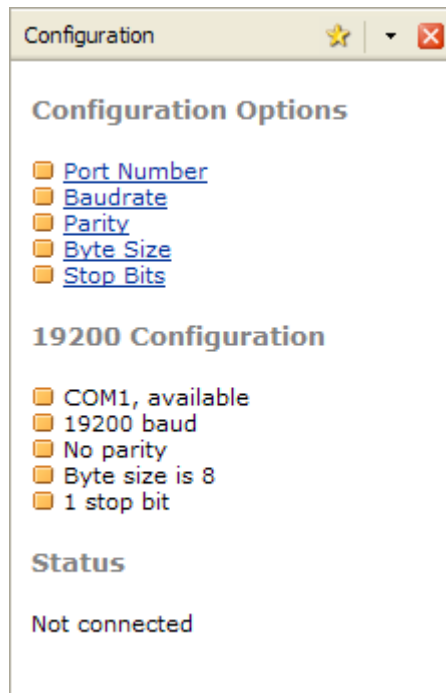

Clicking on a configuration link will display a drop down menu, listing available options. A summary of selected options is shown below the configuration links. For example, in the image above, summary information is displayed under the heading 19200 Configuration.

★ Favourites

Pressing the favourite icon will display a number of options allowing you to add, manage or load configuration favourites.

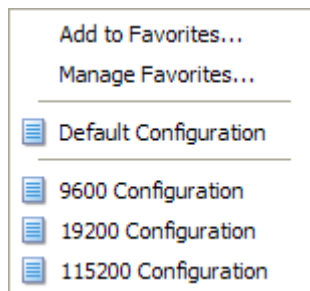

Add to Favourites

Select this option if you wish to save your current configuration. You can give your configuration a unique name, which will be displayed in the favourite drop down menu. For example, 9600 Configuration or 115200 Configuration

Manage Favourites

Select this option to remove a previously saved configuration favourite.

Notes.

After pressing the connect icon on the main toolbar, the configuration window is automatically closed and opened again when disconnect is pressed. If you don't want the configuration window to automatically close, right click on the configuration window and un-check the Auto-Hide option.

Transmit Window

The transmit window enables you to send serial data to an external device connected to a PC serial port. In addition to textual data, the send window also enables you to send control characters. To display a list of transmit options, right click on the transmit window.

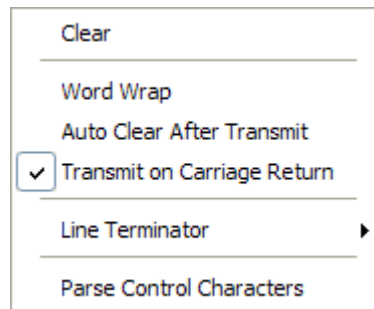

Clear

Clear the contents of the transmit window.

Word Wrap

This option allows you to wrap the text displayed in the transmit window.

Auto Clear After Transmit

Enabling this option will automatically clear the contents of the transmit window when data is sent.

Transmit on Carriage Return

This option will automatically transmit data when the carriage return key is pressed. If this option is disabled, you will need to manually press the send button or press F4 to transmit.

Line Terminator

You can append your data with a number of line terminations characters. These include CR, CR and LF, LF and CR, null and No Terminator.

Parse Control Characters

When enabled, the parse control characters option enables you to send control characters in your message, using either a decimal or hexadecimal notation. For example, if you want to send hello world followed by a carriage return and line feed character, you would use hello world#13#10 for decimal, or hello world\$D\$A for hex. Only numbers in the range 0 to 255 will be converted. For example, sending the message letter #9712345 will be interpreted as letter a12345.

If the sequence of characters does not form a legal number, the sequence is interpreted as normal characters. For example, hello world#here I am. If you don't want characters to be interpreted as a control sequence, but rather send it as normal characters, then all you need to do is use the tilde symbol (~). For example, letter ~#9712345 would be sent as letter #9712345.

Receive Window

The receive window is used to capture data sent from an external device (for example, a PIC MCU) to your PC. To display a list of transmit options, right click on the receive window.

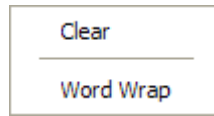

Clear

Clear the contents of the receive window.

Word Wrap

When enabled, incoming data is automatically word wrapped.

Notes.

In order to advance the cursor to the next line in the receive window, you must transmit either a CR (\$D) or a CR LF pair (\$D \$A) from your external device.

Protected Proton24 Compiler Words

Below is a list of protected words that the compiler, assembler or linker uses internally. Be sure not to use any of these words as variable or label names, otherwise errors will be produced.

(A)

Abs, Access_Upper_64K, Acos, AddressOf, ADC_Resolution, Adcin, Adin, Adin_Delay, Adin_Res, Adin_Stime, Adin_Tad, Asin, Asm, Atan, Atan2, Available_RAM

(B)

Bin, Bin1, Bin10, Bin11, Bin12, Bin13, Bin14, Bin15, Bin16, Bin17, Bin18, Bin19, Bin2, Bin20, Bin21, Bin22, Bin23, Bin24, Bin25, Bin26, Bin27, Bin28, Bin29, Bin3, Bin30, Bin31, Bin32, Bin4, Bin5, Bin6, Bin7, Bin8, Bin9, Bit, Bn, Bnc, Bnn, Bnov, Bnz, Bootloader, Bov, Box, Bra, Branch, Branchl, Break, Brestart, Bstart, Bstop, Bus_DelayMs, Bus_SCL, BusAck, Busin, Busout, Button, Button_Delay, Byte, Byte_Math, Bz, Bit_Bit, Bit_Byte, Bit_Dword, Bit_Float, Bit_Word, Bit_Wreg, Byte_Bit, Byte_Byte, Byte_Dword, Byte_Float, Byte_Word, Byte_Wreg

(C)

Call, Case, Cblock, CCP1_Pin, CCP2_Pin, CCP3_Pin, CCP4_Pin, CCP5_Pin, Cdata, Cerase, Chr\$, Circle, Clear, ClearBit, ClearPin, Cls, Code, Config, Constant, Continue, Core, Cos, Count, Counter, CPtr8, CPtr16, CPtr32, CPtr64, Cread, Cread8, Cread16, Cread32, Cread64, Cursor, Cwrite

(D)

Data, Dcd, Dead_Code_Remove, Dword_Bit, Dword_Byte, Dword_Dword, Dword_Float, Dword_Word, Dword_Wreg, Debug_Req, Debugin, Dec, Dec, Dec1, Dec1, Dec10, Dec2, Dec2, Dec3, Dec3, Dec4, Dec4, Dec5, Dec5, Dec6, Dec6, Dec7, Dec7, Dec8, Dec8, Dec9, Declare, Decrement, Define, Delays, Delayus, DelayCs, Device, Dig, Dim, Djc, Djnc, Djnz, Djz, Dt, DTMfout, Dw, Dword, Double, dSin, dCos, dTan, dExp, dLog, dLog10, dAtan, dAtan2, dAsin, dAcos, dSqr, dAbs, Do

(E)

Edata, Eeprom_Size, Else, Elseif, End, EndAsm, Endlf, EndM, EndSelect, EndProc, Equ, Eread, Error, ErrorLevel, Ewrite, ExitM, Exp, Expand

(F)

Fill, Fix16_8Add, Fix16_8Div, Fix16_8Greater, Fix16_8GreaterEqual, Fix16_8Less, Fix16_8LessEqual, Fix16_8Mul, Fix16_8Sub, Fix16_8ToFloat, Fix16_8ToInt, Fix8_8Add, Fix8_8Div, Fix8_8Greater, Fix8_8GreaterEqual, Fix8_8Less, Fix8_8LessEqual, Fix8_8Mul, Fix8_8Sub, Fix8_8ToFloat, Fix8_8ToInt, Flash_Capable, Float, Float_Display_Type, Float_Rounding, FloatToFix16_8, FloatToFix8_8, Font_Addr, For, Freqout, Float_Bit, Float_Byte, Float_Dword, Float_Float, Float_Word, Float_Wreg, fAbs

(G)

GetBit, GetPin, GLCD_CS_Invert, GLCD_Fast_Strobe, GLCD_Read_Delay, GLCD_Strobe_Delay, Gosub, GoTo

(H)

HbRestart, HbStart, HbStop, Hbus_Bitrate, HbusAck, Hbusin, Hbusout, Hex, Hex1, Hex2, Hex3, Hex4, Hex4, Hex5, Hex6, Hex7, Hex8, Hig, HighLow_Tris_Reverse, Hpwm, Hrsin, Hrsin1, Hrsin2, Hrsin3, Hrsin4, Hrsout, Hrsout1, Hrsout2, Hrsout3, Hrsout4, Hserin, Hserin1, Hserin2, Hserin3, Hserin4, Hserout, Hserout1, Hserout2, Hserout3, Hserout4, Hserial_Baud, Hserial1_Baud, Hserial2_Baud, Hserial3_Baud, Hserial4_Baud, Hserial_Clear, Hserial1_Clear, Hserial2_Clear, Hserial3_Clear, Hserial4_Clear, Hserial_Parity, Hserial1_Parity, Hserial2_Parity, Hserial3_Parity, Hserial4_Parity

(I)

I2C_Bus_SCL, I2C_Slow_Bus, I2Cin, I2Cout, I2CWrite, I2CRead, ICD_Req, ICos, If, Ijc, Ijnc, Ijnz, Ijz, Inc, Include, Increment, Inkey, Input, Internal_Bus, Internal_Font, IntToFix16_8, IntToFix8_8, Irln, Irln_Pin, ISin, ISqr

(K)

Keyboard_CLK_Pin, Keyboard_DTA_Pin, Keyboard_IN, Keypad_Port

(L)

Label_Word, LCD_CDPin, LCD_CEPin, LCD_CommandUS, LCD_CS1Pin, LCD_CS2Pin, LCD_DataUs, LCD_DTPin, LCD_DTPort, LCD_ENPin, LCD_Font_HEIGHT, LCD_Font_Width, LCD_Graphic_Pages, LCD_Interface, LCD_Lines, LCD_RAM_Size, LCD_RDPin, LCD_RSPin, LCD_RSTPin, LCD_RWPin, LCD_Text_Home_Address, LCD_Text_Pages, LCD_Type, LCD_WRPin, LCD_X_Res, LCD_Y_Res, LCDread, LCDwrite, Ldata, Left\$, Len, Let, Lfsr, Lslf, Lsrf, Library_Core, Line, LineTo, LoadBit, Log, Log10, LookDown, LookDownL, LookUp, LookUpL, Low, Lread, Lread8, Lread16, Lread32, Lread64, Loop

(M)

Macro_Params, Max, Mid\$, Min, Mouse_CLK_Pin, Mouse_Data_Pin, Mouse_In, Movlw, Mssp_Type

(N)

Ncd, Next, Nop, Num_Bit, Num_Byte, Num_Dword, Num_Float, Num_Word, Num_Wreg

(O)

Onboard_Adc, Onboard_USART, Onboard_Usb, Optimiser_Level, Oread, Org, Output, Owin, Owout, Owrite, OSC_PLLDIV

(P)

Pause, Pauseus, Pixel, Plot, Pop, PortB_Pullups, Pot, Pow, Print, Prm_1, Prm_10, Prm_11, Prm_12, Prm_13, Prm_14, Prm_15, Prm_2, Prm_3, Prm_4, Prm_5, Prm_6, Prm_7, Prm_8, Prm_9, Prm_Count, Proton24_Start_Address, PulsIn, PulsIn, Pulsin_Maximum, PulseOut, Push, Pwm, Ptr8, Ptr16, Ptr32, Ptr64, Proc, Pin_A0, Pin_A1, Pin_A2, Pin_A3, Pin_A4, Pin_A5, Pin_A6, Pin_A7, Pin_A8, Pin_A9, Pin_A10, Pin_A11, Pin_A12, Pin_A13, Pin_A14, Pin_A15, Pin_B0, Pin_B1, Pin_B2, Pin_B3, Pin_B4, Pin_B5, Pin_B6, Pin_B7, Pin_B8, Pin_B9, Pin_B10, Pin_B11, Pin_B12, Pin_B13, Pin_B14, Pin_B15, Pin_C0, Pin_C1, Pin_C2, Pin_C3, Pin_C4, Pin_C5, Pin_C6, Pin_C7, Pin_C8, Pin_C9, Pin_C10, Pin_C11, Pin_C12, Pin_C13, Pin_C14, Pin_C15, Pin_D0, Pin_D1, Pin_D2, Pin_D3, Pin_D4, Pin_D5, Pin_D6, Pin_D7, Pin_D8, Pin_D9, Pin_D10, Pin_D11, Pin_D12, Pin_D13, Pin_D14, Pin_D15, Pin_E0, Pin_E1, Pin_E2, Pin_E3, Pin_E4, Pin_E5, Pin_E6, Pin_E7, Pin_E8, Pin_E9, Pin_E10, Pin_E11, Pin_E12, Pin_E13, Pin_E14, Pin_E15, Pin_F0, Pin_F1, Pin_F2, Pin_F3, Pin_F4, Pin_F5, Pin_F6, Pin_F7, Pin_F8, Pin_F9, Pin_F10, Pin_F11, Pin_F12, Pin_F13, Pin_F14, Pin_F15, Pin_G0, Pin_G1, Pin_G2, Pin_G3, Pin_G4, Pin_G5, Pin_G6, Pin_G7, Pin_G8, Pin_G9, Pin_G10, Pin_G11, Pin_G12, Pin_G13, Pin_G14, Pin_G15, Pin_H0, Pin_H1, Pin_H2, Pin_H3, Pin_H4, Pin_H5, Pin_H6, Pin_H7, Pin_H8, Pin_H9, Pin_H10, Pin_H11, Pin_H12, Pin_H13, Pin_H14, Pin_H15, Pin_J0, Pin_J1, Pin_J2, Pin_J3, Pin_J4, Pin_J5, Pin_J6, Pin_J7, Pin_J8, Pin_J9, Pin_J10, Pin_J11, Pin_J12, Pin_J13, Pin_J14, Pin_J15, Pin_K0, Pin_K1, Pin_K2, Pin_K3, Pin_K4, Pin_K5, Pin_K6, Pin_K7, Pin_L0, Pin_L1, Pin_L2, Pin_L3, Pin_L4, Pin_L5, Pin_L6, Pin_L7

(R)

Random, RC5in, RC5in_Extended, RC5in_Pin, RCall, RCin, RcTime, Read, Rem, Remarks, Reminders, Rep, Repeat, Res, Retfie, Retlw, Return, Return_Type, Return_Var, Rev, Right\$, Rol, Ror, Rsin, Rsin_Mode, Rsin_Pin, Rsin_Timeout, Rsout, Rsout_Baud, Rsout_Mode, Rsout_Pace, Rsout_Pin, Return_Bit, Return_Byte, Return_Dword, Return_Float, Return_Word, Return_Wreg

(S)

SCL_Pin, SDA_Pin, Seed, Select, Serial_Baud, Serial_Data, Serial_Parity, Serin, Serout, Servo, Set, SetBit, SetPin, Shift_DelayUs, ShiftIn, Shin, Shout, Show_Expression_Parts, Show_System_Variables, Signed_Dword_Terms, Sin, SizeOf, Sleep, Slow_Bus, Small_Micro_Model, Snooze, SonyIn, SonyIn_Pin, Sound, Sound2, Sqr, Stack_Size, Step, Stop, Str, Str\$, Str\$, StrCmp, String, Strn, Swap, Symbol, Setup_PLL, Sbyte, Sword, Sdword

(T)

Tan, Then, To, Toggle, ToLower, Toshiba_Command, Toshiba_UDG, ToUpper, Touch_Active, Touch_Read, Touch_HotSpot, Touch_HotSpotTable, Trim, TrimLeft, TrimRight

(U)

Udata, UnPlot, Until, Upper

(V)

Val, Var, Variable, VarPtr

(W)

Wait, Warnings, WatchDog, Wend, While, Word, Write, Word_Bit, Word_Byte, Word_Dword, Word_Float, Word_Word, Word_Wreg, Wreg_Bit, Wreg_Byte, Wreg_Dword, Wreg_Float, Wreg_Word, Write_OSCCON, Write_OSCCONL, Write_OSCCONH

(X)

Xtal

_adc, _adcsres, _code, _core, _defined, _device, _eeprom, _flash, _mssp, _ports, _ram, _type, _uart, _usb, _xtal