



www.soiseek.com — IC Seeker

IC Search

Try Luck

Tips: Try multiple keywords. e.g. Atmel 8 bit microcontroller

[IC Catalog](#) - [About Soiseek](#) - [Feedback](#)

[Make Soiseek Your Homepage](#)

Copyright Notice:

All the datasheets that Soiseek provides are edited by their manufacturers.

All copyrights of the datasheets reserved by their manufacturers.

Soiseek is NOT responsible for the correctness of any datasheet contents.

Please tell us if any advices. We are always dedicated to offering the best search experience.

Contact us: <http://www.soiseek.com/tellus>

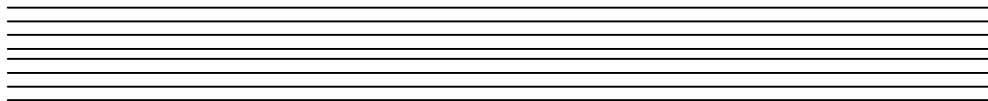

Sitronix

ST7920

Chinese Fonts built in LCD controller/driver

Main Features

- I Operation Voltage Range:
 - Ø 2.7V to 5.5V
- I Support 8-bit, 4-bit and serial bus MPU interface
- I 64 x 16-bit display RAM (DDRAM)
 - Ø Supports 16 words x 4 lines (Max)
 - Ø LCD display range 16 words x 2 lines
- I 64 x 256-bit Graphic Display RAM (GDRAM)
- I 2M-bits Character Generation ROM (CGROM):
 - Support 8192 Chinese words (16x16 dot matrix)
- I 16K-bit half-width Character Generation ROM (HCGROM):
 - Supports 126 characters (16x8 dot matrix)
- I 32-common x 64-segment (2 lines of character) LCD drivers
- I Automatic power on reset (POR)
- I External reset pin (XRESET)
- I With the extension segment drivers, the display area can up to 16x2 lines
- I Built-in RC oscillator:
 - Frequency is adjusted by an external resistor
- I Low power consumption design
 - Ø Normal mode (450uA Typ VDD=5V)
 - Ø Standby mode (30uA Max VDD=5V)
- I VLCD (V0 to V_{SS}): max 7V
- I Graphic and character mixed display mode
- I Multiple instructions:
 - Ø Display Clear
 - Ø Return Home
 - Ø Display ON/OFF
 - Ø Cursor ON/OFF
 - Ø Display Character Blink
 - Ø Cursor Shift
 - Ø Display Shift
 - Ø Vertical Line Scroll
 - Ø Reverse Display (by line)
 - Ø Standby Mode
- I Built-in voltage booster (2 times)
 - VOUT: max 7V
- I 1/33 Duty (with ICON)

Function Description

ST7920 LCD controller/driver IC can display alphabets, numbers, Chinese fonts and self-defined characters. It supports 3 kinds of bus interface, namely 8-bit, 4-bit and serial. All functions, including display RAM, Character Generation ROM, LCD display drivers and control circuits are all in a one-chip solution. With a minimum system configuration, a Chinese character display system can be easily achieved.

ST7920 includes character ROM with 8192 16x16 dots Chinese fonts and 126 16x8 dots half-width alphanumerical fonts. Besides, it supports 64x256 dots graphic display area for graphic display (GDRAM). Mix-mode display with both character and graphic data is possible. ST7920 has built-in CGRAM and provide 4 sets software programmable 16x16 fonts.

ST7920 has wide operating voltage range (2.7V to 5.5V). It also has low power consumption. So ST7920 is suitable for battery-powered portable device.

ST7920 LCD driver consists of 32-common and 64-segment. Company with the extension segment driver (ST7921) ST7920 can support up to 32-common x 256-segment display.

Part Number	Font Code
ST7920-0A	BIG-5 Code Set (Traditional Chinese)
ST7920-0B	GB Code Set (Simplified Chinese)
ST7920-0C	Chinese (Traditional/Simplified) & Japanese
ST7920-0F	Chinese (Traditional/Simplified), Japanese & Korean

ST7920

ST7920 Specification Reversion History		
Version	Date	Description
C1.7	2000/12/15	<ol style="list-style-type: none"> 1. VCC changed to VDD. 2. VLCD changed from VCC-V5 to V0-VSS. 3. DC characteristics input High voltage (Vih) changed to 0.7VDD. 4. DC characteristics output High voltage (Voh) changed to 0.8VDD.
C1.8	2001/03/01	<ol style="list-style-type: none"> 1. Chip Size changed. 2. ICON 256 dots changed to 240 dots. 3. XOFF normal high sleep Low changed to normal low sleep High. 4. Added XOFF application. 5. Modified application of ST7920: PIN 4~6 are floating. (PIN 4~6 are test pin) 6. Modified voltage doubler CAP1P, CAP1M, CAP2M capacitors polarity
C1.9	2001/05/28	<ol style="list-style-type: none"> 1. Icon RAM TABLE changed. (TABLE-6) 2. Booster description modified. (PAGE-29) 3. AC Characteristics modified. 4. Added 2Line 16 Chinese Word (32Com X 256Seg) application circuit. 5. Added oscillation resistor's relation to power consumption and frequency.
C2.0	2001/07/03	<ol style="list-style-type: none"> 1. Added Register initial values. 2. Voltage booster CAP1M CAP1P polarity changed (PAGE-30).
V2.0	2001/08/17	<ol style="list-style-type: none"> 1. Modified Table 7 (PAGE-14). 2. Change to English version.
V2.0c	2001/10/18	<ol style="list-style-type: none"> 1. Modified page-38 Serial interface timing diagram.
V2.0d	2002/05/09	<ol style="list-style-type: none"> 1. Add the standard code (Japan, GB code, BIG-5 code).
V3.0	2002/10/11	<ol style="list-style-type: none"> 1. Delete sleep mode function.
V3.1	2003/04/11	<ol style="list-style-type: none"> 1. Modified GDRAM Address (AC5...AC0, 00h...3Fh).
V3.2	2003/09/09	<ol style="list-style-type: none"> 1. Add the CGROM and HCGROM test application circuit.
V3.3	2004/03/29	<ol style="list-style-type: none"> 1. Updat the using method for ICON.
V3.4	2005/5/24	<ol style="list-style-type: none"> 1. ICON no used.
V3.5	2005/5/24	<ol style="list-style-type: none"> 1. Add VOUT voltage limitation. 2. Remove IRAM related descriptions.
V3.6	2005/6/6	<ol style="list-style-type: none"> 1. Fix the check sum count number on Page 28~30. 655360->655362, 10240->10242. 2. Modify the description about serial interface.
V3.7	2007/7/24	<ol style="list-style-type: none"> 1. Add CGROM/HCGROM checksum operation time.
V3.8	2007/12/20	<ol style="list-style-type: none"> 1. Add "Clear DDRAM" step before check sum process.
V3.9	2008/3/3	<ol style="list-style-type: none"> 1. Modify 4-bit initial sequence.
V4.0	2008/8/18	<ol style="list-style-type: none"> 1. Add Font Code "0F" at Page 1. 2. Modify the description of Font Code Table at Page 1.

ST7920

System Block Diagram

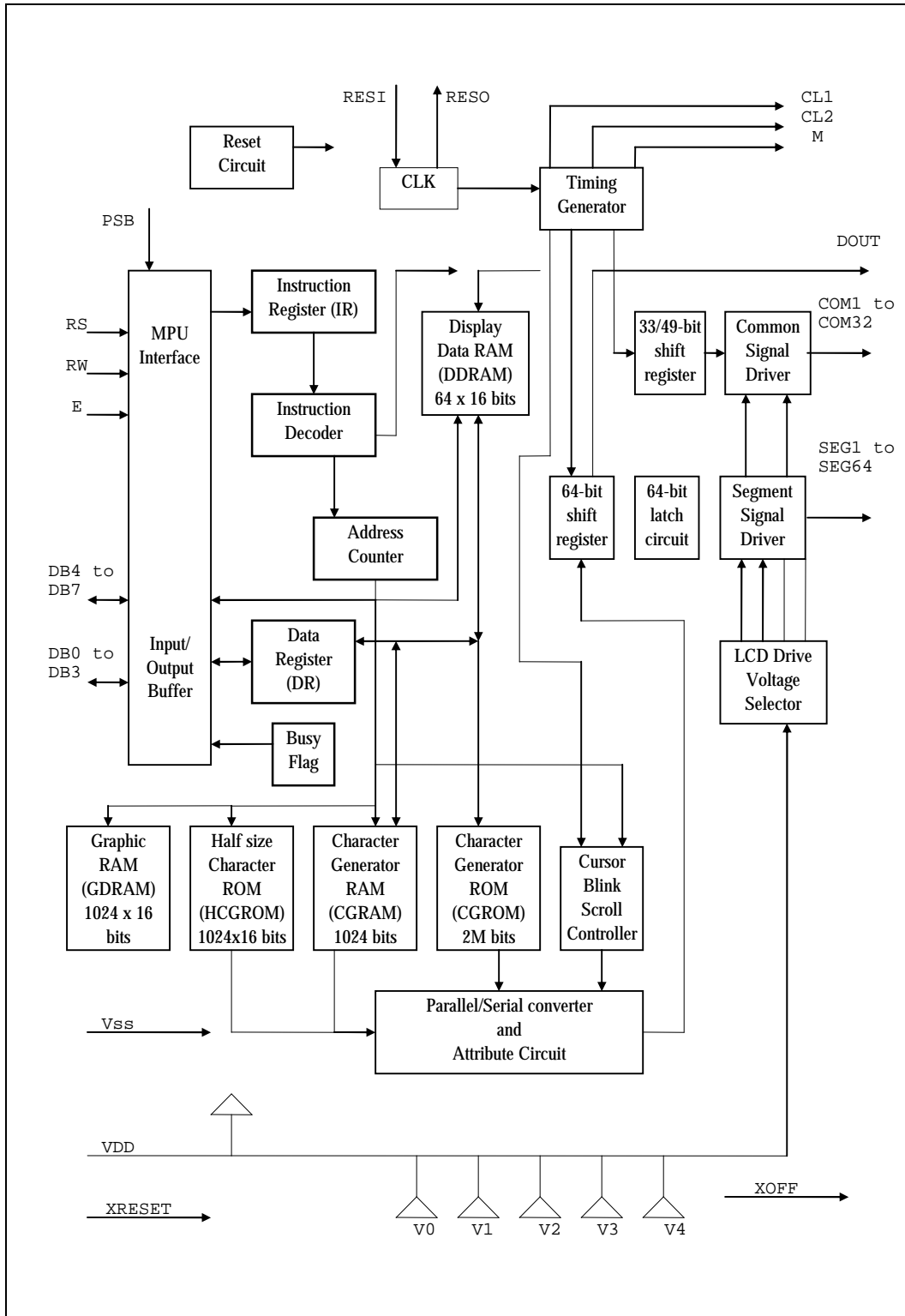

ST7920

PAD Coordinates

(Unit: um)

No.	Name	X	Y
1	V0	-2548	1812
2	V1	-2548	1688
3	V2	-2548	1562
4	CLK	-2548	1438
5	TT1	-2548	1312
6	TT2	-2548	1188
7	V3	-2548	1062
8	V4	-2548	938
9	VSS	-2548	812
10	VDD	-2548	688
11	XRESET	-2548	562
12	CL1	-2548	438
13	CL2	-2548	312
14	VDD	-2548	188
15	M	-2548	62
16	DOUT	-2548	-62
17	RS	-2548	-188
18	RW	-2548	-312
19	E	-2548	-438
20	VSS	-2548	-562
21	OSC1	-2548	-688
22	OSC2	-2548	-812
23	PSB	-2548	-938
24	D0	-2548	-1062
25	D1	-2548	-1188
26	D2	-2548	-1312
27	D3	-2548	-1438
28	D4	-2548	-1562
29	D5	-2548	-1688
30	D6	-2548	-1812
31	D7	-2306	-1933
32	XOFF	-2181	-1933
33	VOUT	-2056	-1933
34	CAP3M	-1931	-1933
35	CAP1P	-1806	-1933
36	CAP1M	-1681	-1933
37	CAP2P	-1556	-1933
38	CAP2M	-1431	-1933

No.	Name	X	Y
39	VD2	-1306	-1933
40	C[1]	-1181	-1933
41	C[2]	-1056	-1933
42	C[3]	-931	-1933
43	C[4]	-806	-1933
44	C[5]	-681	-1933
45	C[6]	-556	-1933
46	C[7]	-431	-1933
47	C[8]	-306	-1933
48	C[9]	-181	-1933
49	C[10]	-56	-1933
50	C[11]	69	-1933
51	C[12]	194	-1933
52	C[13]	319	-1933
53	C[14]	444	-1933
54	C[15]	569	-1933
55	C[16]	694	-1933
56	C[17]	819	-1933
57	C[18]	944	-1933
58	C[19]	1069	-1933
59	C[20]	1194	-1933
60	C[21]	1319	-1933
61	C[22]	1444	-1933
62	C[23]	1569	-1933
63	C[24]	1694	-1933
64	C[25]	1819	-1933
65	C[26]	1944	-1933
66	C[27]	2069	-1933
67	C[28]	2194	-1933
68	C[29]	2319	-1933
69	C[30]	2548	-1812
70	C[31]	2548	-1688
71	C[32]	2548	-1562
72	C[33] Not use	2548	-1438
73	S[64]	2548	-1312
74	S[63]	2548	-1188
75	S[62]	2548	-1062
76	S[61]	2548	-938

ST7920

No.	Name	X	Y
77	S[60]	2548	-812
78	S[59]	2548	-688
79	S[58]	2548	-562
80	S[57]	2548	-438
81	S[56]	2548	-312
82	S[55]	2548	-188
83	S[54]	2548	-62
84	S[53]	2548	62
85	S[52]	2548	188
86	S[51]	2548	312
87	S[50]	2548	438
88	S[49]	2548	562
89	S[48]	2548	688
90	S[47]	2548	812
91	S[46]	2548	938
92	S[45]	2548	1062
93	S[44]	2548	1188
94	S[43]	2548	1312
95	S[42]	2548	1438
96	S[41]	2548	1562
97	S[40]	2548	1688
98	S[39]	2548	1812
99	S[38]	2319	1933
100	S[37]	2194	1933
101	S[36]	2069	1933
102	S[35]	1944	1933
103	S[34]	1819	1933
104	S[33]	1694	1933
105	S[32]	1569	1933
106	S[31]	1444	1933
107	S[30]	1319	1933
108	S[29]	1194	1933
109	S[28]	1069	1933
110	S[27]	944	1933
111	S[26]	819	1933
112	S[25]	694	1933
113	S[24]	569	1933
114	S[23]	444	1933
115	S[22]	319	1933

No.	Name	X	Y
116	S[21]	194	1933
117	S[20]	69	1933
118	S[19]	-56	1933
119	S[18]	-181	1933
120	S[17]	-306	1933
121	S[16]	-431	1933
122	S[15]	-556	1933
123	S[14]	-681	1933
124	S[13]	-806	1933
125	S[12]	-931	1933
126	S[11]	-1056	1933
127	S[10]	-1181	1933
128	S[9]	-1306	1933
129	S[8]	-1431	1933
130	S[7]	-1556	1933
131	S[6]	-1681	1933
132	S[5]	-1806	1933
133	S[4]	-1931	1933
134	S[3]	-2056	1933
135	S[2]	-2181	1933
136	S[1]	-2306	1933

ST7920

Pin Description

Name	No.	I/O	Connects to	Function
XRESET	11	I	—	System reset input (low active).
PSB	23	I	—	Interface selection: 0: serial mode; 1: 8/4-bit parallel bus mode.
RS(CS*)	17	I	MPU	Parallel Mode: Register select. 0: Select instruction register (write) or busy flag, address counter (read); 1: Select data register (write/read). Serial mode: Chip select. 1: chip enabled; 0: chip disabled. When chip is disabled, SID and SCLK should be set as "H" or "L". Transcient of SID and SCLK is not allowed.
RW(SID*)	18	I	MPU	Parallel Mode: Read/Write control. 0: Write; 1: Read. Serial Mode: Sserial data input.
E(SCLK*)	19	I	MPU	Parallel Mode: 1: Enable trigger. Serial Mode: Serial clock.
D4 to D7	28~31	I/O	MPU	Higher nibble data bus of 8-bit interface and data bus for 4-bit interface
D0 to D3	24~27	I/O	MPU	Lower nibble data bus of 8-bit interface.
CL1	12	O	Extension segment drv.	Latch signal for extension segment drivers.
CL2	13	O	Extension segment drv.	Shift clock for extension segment drivers.
M	15	O	Extension segment drv.	AC signal for extension segment drivers voltage inversion.
DOUT	16	O	Extension segment drv.	Data output for extension segment drivers.
COM1 to COM32	40~71	O	LCD	Common signals.
SEG1 to SEG64	136~73	O	LCD	Segment signals.
V0 to V4	1~3,7,8	—	—	LCD bias voltage. $V_0 \sim V_4 \leq 7V$.
V _{DD}	10,14	I	Power	$V_{DD} : 2.7V \text{ to } 5.5V$.
V _{SS}	9,20	I	Power	$V_{SS} : 0V$.
OSC1, OSC2	21,22	I, O	Resistors	Using internal oscillator: 5.0V R=33K; 2.7V R=18K. Using external clock: Use OSC1 as external clock input.
VOU _T	33	O	Resistors	LCD voltage doubler output. $V_{OUT} \leq 7V$.

***Note:** The OSC pin must have the shortest wiring pattern of all other pins. To prevent noise from other signal lines, it should also be enclosed by the largest GND pattern. Poor anti-noise characteristics on the OSC line will result in malfunction, or adversely affect the clock's duty ratio.

ST7920

Pin Description (continued)

Name	No.	I/O	Connects to	Description
CAP3M CAP1P CAP1M CAP2M	34 35 36 38	I/O	Capacitors	Capacitor pins for voltage doubler Voltage $\leq 7V$.
XOFF	32	O	—	Reserved (no connection).
CAP2P	37	—	—	Reserved (no connection).
C[33]	72	O	—	Reserved (no connection).
VD2	39	I	Reference voltage	Voltage doubler reference voltage. If use internal voltage doubler, please make sure that: I $VD2 \leq 3.5V$ or I $VOUT \leq 7V$ and $CAP3M \leq 7V$.
CLK TT1 TT2	4 5 6	I	— — —	For CGROM/HCGROM checksum. Refer to checksum application.

Note:

1. $7V \geq VOUT \geq V0 \geq V1 \geq V2 \geq V3 \geq V4$ must be maintained
2. Two clock options: As shown below.

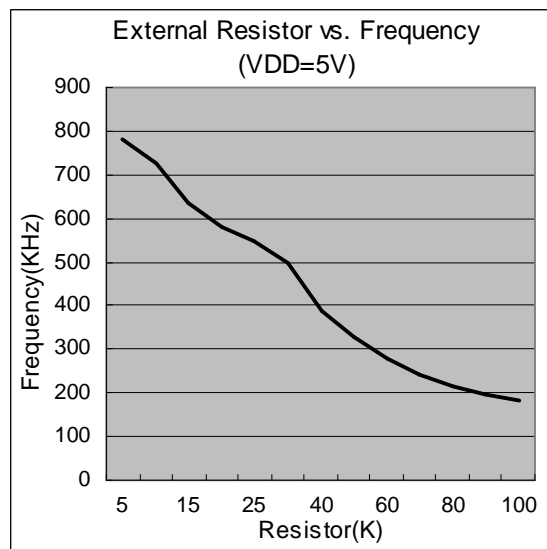
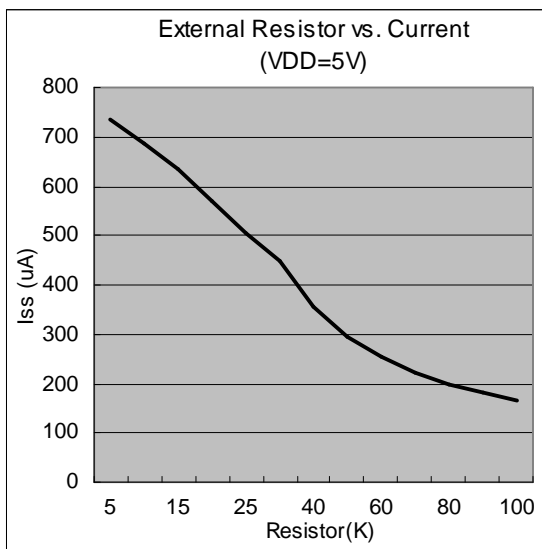
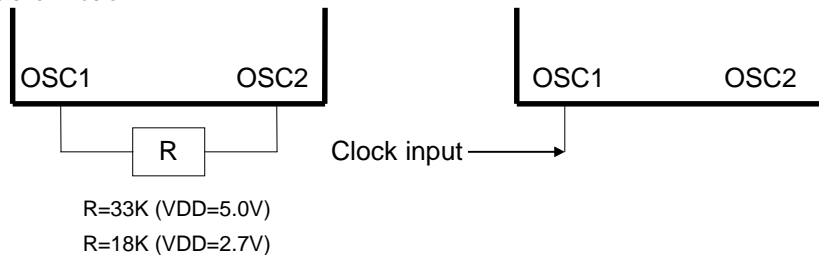

3. When using voltage doubler (VOOUT), it is recommended that the sum of those divide resistors (R1~R5) should be larger than 20K Ohm. So that the voltage doubler can provide sufficient power.

ST7920

Voltage Doubler

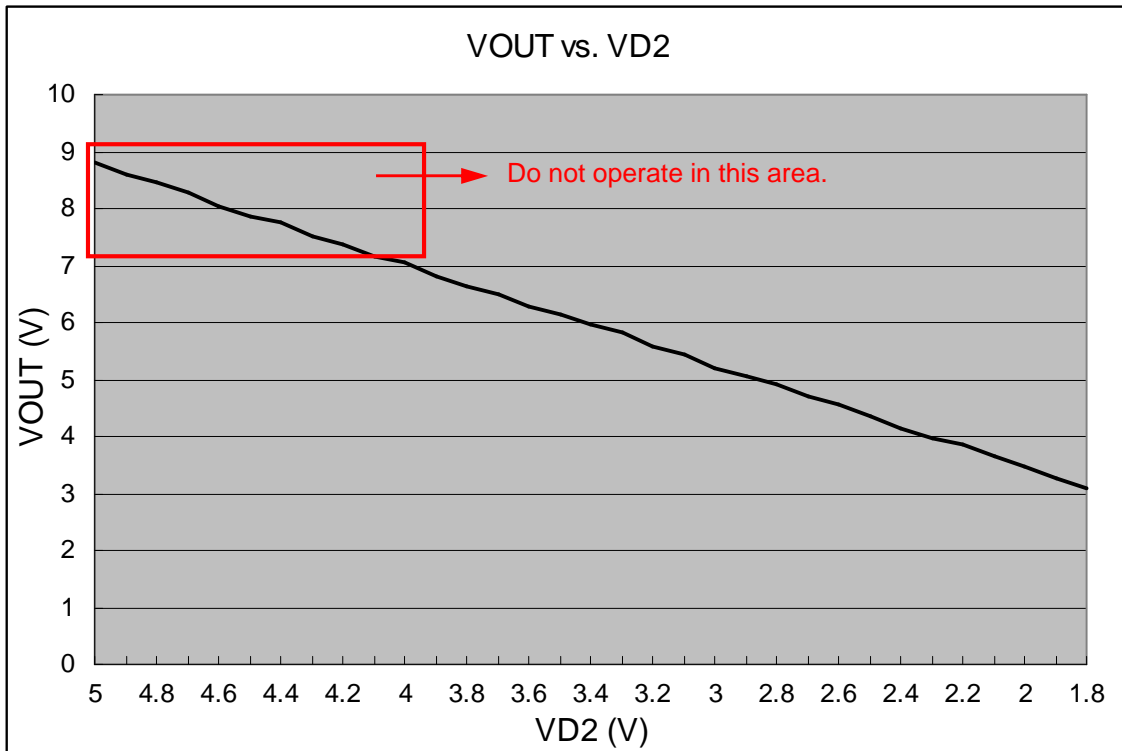
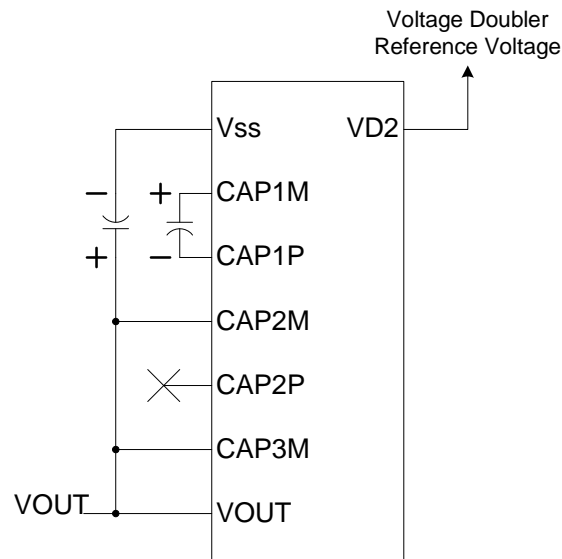

Voltage Doubler mode: VD2 & Vout output characteristic

Notes:

- I Total resistance of the Follower dividing resistors should larger than 20K Ohm.
- I Booster Capacitor uses 4.7uF
- I Panel size: 80mm x 28mm (check display)

ST7920

Function Description

System interface

ST7920 supports 3 kinds of bus interface to communicate with MPU: 8-bit parallel, 4-bit parallel and clock synchronized serial interface. Parallel interface is selected by PSB="1" and serial interface is by PSB="0". 8-bit / 4-bit interface is selected by function set instruction DL bit.

Two 8-bit registers (Data Register DR and Instruction Register IR) are used in ST7920 to access DRAM or Register. Data Register (DR) can access DDRAM, CGRAM and GDRAM through the address pointer implemented by Address Counter (AC). Instruction Register (IR) stores the instruction sent by MPU to ST7920.

4 kinds of parallel interface access mode can be selected through RS and RW:

RS	RW	Description
L	L	MPU write instruction to instruction register (IR)
L	H	MPU read busy flag (BF) and address counter (AC)
H	L	MPU write data to data register (DR)
H	H	MPU read data from data register (DR)

* The serial interface access modes do not have Read operation.

Busy Flag (BF)

ST7920 needs a process time for any received instruction. Before finishing the received instruction, any further instruction is not accepted. The process time of each instruction is not equal and the internal process is finished or not can be determined by the BF. Internal operation is in progress while BF="1", that means ST7920 is in busy state. No further instructions will be accepted until BF="0". MPU must check BF to determine whether the internal operation is finished or not before issuing instruction.

Address Counter (AC)

Address Counter (AC) is used as the address pointer of DDRAM, CGRAM and GDRAM. (AC) can be set by instruction. After that, accesses (Read/Write operations) to the memories, such as DDRAM, CGRAM or GDRAM, (AC) will be increased or decreased by 1 (according to the setting in "Entry Mode Set" Register). When RS="0", RW="1" and E="1" the value of (AC) will be output to DB6~DB0.

Character Generation ROM (CGROM) and Half-width Character Generation ROM (HCGROM)

ST7920 is built in a Character Generation ROM (CGROM) to provide 8192 16x16 character fonts and a Half-width Character Generation ROM to provide 126 8x16 alphanumeric characters. It is easy to support multi-language applications such as Chinese and English. Two consecutive bytes are used to specify one 16x16 character or two 8x16 half-width characters. Character codes are written into DDRAM and the corresponding fonts are mapped from CGROM or HCGROM to the display drivers.

Character Generation RAM (CGRAM)

ST7920 is built in a Character Generation RAM (CGRAM) to support user-defined fonts. Four sets of 16x16 bit-mapped RAM spaces are available. These user-defined fonts are displayed the same ways as CGROM fonts by writing the related character code into the DDRAM.

ST7920

Display Data RAM (DDRAM)

There are 64x2 bytes RAM spaces for the Display Data RAM. It can store display data such as 16 characters (16x16) by 4 lines or 32 characters (8x16) by 4 lines. However, only 2 character-lines (maximum 32 common outputs) can be displayed at one time. Character codes stored in DDRAM will refer to the fonts specified by CGROM, HCGROM and CGRAM.

ST7920 can display half-width HCGROM fonts, user-defined CGRAM fonts and full 16x16 CGROM fonts. The character codes in 0000H~0006H will use user-defined fonts in CGRAM. The character codes in 02H~7FH will use half-width alpha numeric fonts. The character code larger than A1H will be treated as 16x16 fonts and will be combined with the next byte automatically. The 16x16 BIG5 fonts are stored in A140H~D75FH while the 16x16 GB fonts are stored in A1A0H~F7FFH. In short:

- To display HCGROM fonts:
Write 2 bytes of data into DDRAM to display two 8x16 fonts. Each byte represents 1 character.
The data is among 02H~7FH.
- To display CGRAM fonts:
Write 2 bytes of data into DDRAM to display one 16x16 font.
Only 0000H, 0002H, 0004H and 0006H are acceptable.
- To display CGROM fonts:
Write 2 bytes of data into DDRAM to display one 16x16 font.
A140H~D75FH are BIG5 code, A1A0H~F7FFH are GB code.

The higher byte (D15~D8) is written first and the lower byte (D7~D0) is the next.

Please refer to Table 5 for the relationship between DDRAM and the address/data of CGRAM.

CGRAM fonts and CGROM fonts can only be displayed in the start position of each address. (Refer to Table 4)

80		81		82		83		84		85		86		87		88		89		8A		8B		8C		8D		8E		8F	
H	L	H	L	H	L	H	L	H	L	H	L	H	L	H	L	H	L	H	L	H	L	H	L	H	L	H	L	H	L	H	L
S	i	t	r	o	n	i	x	.	.	S	T	7	9	2	0																
矽	創	電	子	.	.	中	文	編	碼	(正	確)																		
矽	創	電	子	.	.	.	中	文	編	碼																					

Table 4

Incorrect start position

ST7920

Graphic RAM (GDRAM)

Graphic Display RAM has 64x256 bits bit-mapped memory space. GDRAM address is set by writing 2 consecutive bytes of vertical address and horizontal address. Two-byte data (16 bits) configures one GDRAM horizontal address. The Address Counter (AC) will be increased by one automatically after receiving the 16-bit data for the next operation. After the horizontal address reaching 0FH, the horizontal address will be set to 00H and the vertical address will not change. The procedure is summarized below:

1. Set vertical address (Y) for GDRAM
2. Set horizontal address (X) for GDRAM
3. Write D15~D8 to GDRAM (first byte)
4. Write D7~D0 to GDRAM (second byte)

Please refer to Table 7 for Graphic Display RAM mapping.

LCD driver

ST7920 embedded LCD driver has 33 commons and 64 segments to drive the LCD panel. Segment data from CGRAM, CGROM and HCGROM are shifted into the 64 bits segment latch to display. Extended segment driver (ST7921) can be used to extend the segment outputs upto 256 segments.

DDRAM data (char. code)				CGRAM Addr.				CGRAM data (higher byte)								CGRAM data (lower byte)															
B15~ B4	B3	B2	B1	B5	B4	B3	B2	B1	B0	D5	D4	D3	D2	D1	D0	D9	D8	D7	D6	D5	D4	D3	D2	D1	D0						
0	X	00	X	00	0	0	0	0	0	0	0	0	0	1	0	0	0	0	0	1	1	0	0	0	0	0					
					0	0	0	1	1	1	1	1	1	0	0	1	0	0	0	0	0	0	0	0	0	0	0	0	0		
					0	0	1	0	0	0	1	0	0	0	0	0	0	0	0	1	0	0	0	1	0	0	1	0	0	0	
					0	0	1	1	0	0	1	0	0	0	0	0	0	0	0	1	1	1	1	1	1	1	1	0	0	0	
					0	1	0	0	0	0	1	0	0	1	0	0	1	0	0	1	0	0	0	1	0	0	0	1	0	0	
					0	1	0	1	0	0	1	1	1	1	0	0	1	0	0	1	0	0	0	0	0	0	1	0	0	0	
					0	1	1	0	0	1	1	0	0	1	0	1	0	1	0	1	0	0	1	0	0	1	0	0	0	0	
					0	1	1	1	1	0	1	0	0	1	0	0	1	1	0	0	1	0	0	1	0	0	1	0	0	0	0
					1	0	0	0	0	0	1	0	0	1	0	0	1	0	0	0	1	0	1	0	0	0	0	0	0	0	0
					1	0	0	1	0	0	1	0	0	1	0	0	1	0	0	0	0	0	0	0	1	0	0	0	0	0	0
					1	0	1	0	0	0	1	0	0	1	0	0	1	0	0	0	0	0	0	1	0	0	0	0	0	0	0
					1	0	1	1	0	0	1	1	1	1	0	0	0	0	0	0	0	0	0	1	0	0	0	0	0	0	0
					1	1	0	0	0	0	1	1	1	1	0	0	0	0	0	0	0	0	0	1	0	0	0	0	0	0	0
					1	1	0	1	0	0	0	0	0	0	0	0	0	0	0	0	0	0	0	1	0	0	0	0	0	0	0
					1	1	1	0	0	0	0	0	0	0	0	0	0	0	0	0	0	0	0	0	0	0	0	0	0	0	0
					1	1	1	1	0	0	0	0	0	0	0	0	0	0	0	0	0	0	0	0	0	0	0	0	0	0	0
0	X	01	X	01	0	0	0	0	0	0	0	0	1	1	0	0	0	0	0	0	0	0	0	1	1	0					
					0	0	0	1	0	0	0	1	1	0	1	0	0	0	0	0	0	0	0	0	0	0	1	0	0		
					0	0	1	0	0	0	1	0	0	0	0	0	1	0	0	1	0	0	1	1	0	1	0	0	0		
					0	0	1	1	0	1	0	1	1	1	0	1	1	0	1	1	0	1	0	0	1	0	0	1	0	0	
					0	1	0	0	1	0	0	0	0	0	0	0	0	0	0	1	0	1	0	0	1	0	0	1	0	0	
					0	1	0	1	0	1	1	1	1	1	1	1	1	0	0	1	0	0	1	0	0	1	0	0	1	0	
					0	1	1	0	0	1	0	0	0	0	0	0	0	1	0	0	1	0	0	1	0	0	1	0	0	0	
					0	1	1	1	0	1	1	1	1	1	1	1	1	1	0	0	1	0	0	1	0	0	1	0	0	0	0
					1	0	0	0	0	1	0	0	0	0	0	0	0	1	0	0	1	0	0	1	0	0	1	0	0	0	0
					1	0	0	1	0	1	1	1	1	1	1	1	1	0	0	1	0	0	1	0	0	1	0	0	1	0	0
					1	0	1	0	0	1	0	0	0	0	0	0	0	0	0	0	0	0	0	1	0	0	1	0	0	0	0
					1	0	1	1	0	1	1	1	1	1	1	1	1	0	0	0	0	0	0	1	0	0	1	0	0	0	0
					1	1	0	0	1	0	1	0	0	0	0	0	0	0	0	0	0	0	0	1	0	1	0	0	1	0	0
					1	1	0	1	1	0	1	1	1	1	1	1	1	0	0	1	1	1	0	0	1	1	1	0	0	0	0
					1	1	1	0	1	0	1	0	0	0	0	0	0	0	0	0	0	0	0	1	0	0	0	1	0	0	0
					1	1	1	1	0	0	0	0	0	0	0	0	0	0	0	0	0	0	0	0	0	0	0	0	0	0	0

Table 5: DDRAM data (character code) vs. CGRAM data/address map

Note:

1. DDRAM data (character code) bit1 and bit2 are identical with CGRAM address bit4 and bit5.
2. CGRAM address bit0 to bit3 specify total 16 rows. Row-16 is for cursor display. The data in Row-16 will be logically OR to the cursor.
3. CGRAM data for each address is 16 bits.
4. To select the CGRAM font, the bit4 through bit15 of DDRAM data must be "0" while bit0 and bit3 are "don't care".

ST7920

H/L	0	1	2	3	4	5	6	7	8	9	A	B	C	D	E	F
0		☺	☹	♥	♣	♠	♣	•	◐	◑	♂	♀	♫	♫	✂	
1	▶	◀	‡	!!	¶	§	—	‡	↑	↓	→	←	└	↔	▲	▼
2		!	"	#	\$	%	&	'	()	*	+	,	-	.	/
3	0	1	2	3	4	5	6	7	8	9	:	;	<	=	>	?
4	@	A	B	C	D	E	F	G	H	I	J	K	L	M	N	O
5	P	Q	R	S	T	U	V	W	X	Y	Z	[\]	^	_
6	`	a	b	c	d	e	f	g	h	i	j	k	l	m	n	o
7	p	q	r	s	t	u	v	w	x	y	z	{		}	~	Δ

Table 6 16x8 half-width characters

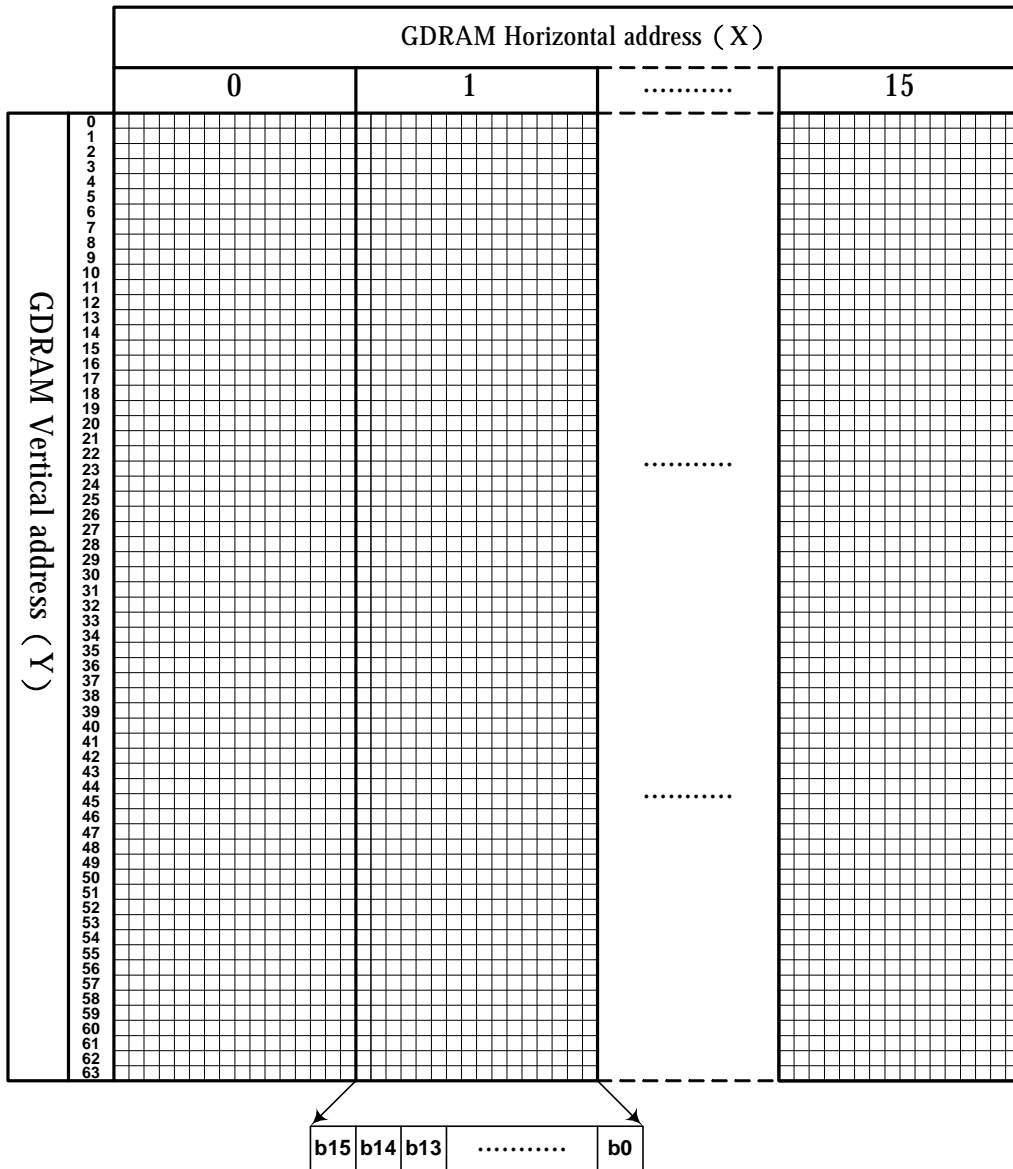

Table 7 GDRAM display coordinates and corresponding address

ST7920

Instructions

ST7920 offers basic instruction set and extended instruction set:

Instruction Set 1: (RE=0: Basic Instruction)

Inst.	Code										Description	Exec time (540KHZ)	
	RS	RW	DB7	DB6	DB5	DB4	DB3	DB2	DB1	DB0			
Display Clear	0	0	0	0	0	0	0	0	0	1	Fill DDRAM with "20H" and set DDRAM address counter (AC) to "00H".	1.6 ms	
Return Home	0	0	0	0	0	0	0	0	0	1	X	Set DDRAM address counter (AC) to "00H", and put cursor to origin ; the content of DDRAM are not changed	72 us
Entry Mode Set	0	0	0	0	0	0	0	0	1	I/D	S	Set cursor position and display shift when doing write or read operation	72 us
Display Control	0	0	0	0	0	0	0	1	D	C	B	D=1: Display ON C=1: Cursor ON B=1: Character Blink ON	72 us
Cursor Display Control	0	0	0	0	0	1	S/C	R/L	X	X	Cursor position and display shift control; the content of DDRAM are not changed	72 us	
Function Set	0	0	0	0	1	DL	X	0	X	X	DL=1 8-bit interface DL=0 4-bit interface RE=1: extended instruction RE=0: basic instruction	72 us	
Set CGRAM Address.	0	0	0	1	AC5	AC4	AC3	AC2	AC1	AC0	Set CGRAM address to address counter (AC) Make sure that in extended instruction SR=0 (scroll or RAM address select)	72 us	
Set DDRAM Address.	0	0	1	0	AC5	AC4	AC3	AC2	AC1	AC0	Set DDRAM address to address counter (AC) AC6 is fixed to 0	72 us	
Read Busy Flag (BF) & AC.	0	1	BF	AC6	AC5	AC4	AC3	AC2	AC1	AC0	Read busy flag (BF) for completion of internal operation, also Read out the value of address counter (AC)	0 us	
Write RAM	1	0	D7	D6	D5	D4	D3	D2	D1	D0	Write data to internal RAM (DDRAM/CGRAM/GDRAM)	72 us	
Read RAM	1	1	D7	D6	D5	D4	D3	D2	D1	D0	Read data from internal RAM (DDRAM/CGRAM/GDRAM)	72 us	

ST7920

Instruction set 2: (RE=1: extended instruction)

Inst.	Code										Description	Exec time (540KHZ)
	RS	RW	DB7	DB6	DB5	DB4	DB3	DB2	DB1	DB0		
Standby	0	0	0	0	0	0	0	0	0	1	Enter standby mode, any other instruction can terminate. COM1...32 are halted.	72 us
Scroll or RAM Address. Select	0	0	0	0	0	0	0	0	1	SR	SR=1: enable vertical scroll position SR=0: enable CGRAM address (basic instruction)	72 us
Reverse (by line)	0	0	0	0	0	0	0	1	R1	R0	Select 1 out of 4 line (in DDRAM) and decide whether to reverse the display by toggling this instruction R1,R0 initial value is 0,0	72 us
Extended Function Set	0	0	0	0	1	DL	X	1 RE	G	0	DL=1 :8-bit interface DL=0 :4-bit interface RE=1: extended instruction set RE=0: basic instruction set G=1 :graphic display ON G=0 :graphic display OFF	72 us
Set Scroll Address	0	0	0	1	AC5	AC4	AC3	AC2	AC1	AC0	SR=1: AC5-AC0 the address of vertical scroll	72 us
Set Graphic Display RAM Address	0	0	1	0 0	0 AC5	0 AC4	AC3 AC3	AC2 AC2	AC1 AC1	AC0 AC0	Set GDRAM address to address counter (AC) Set the vertical address first and followed the horizontal address by consecutive writings Vertical address range: AC5...AC0 Horizontal address range: AC3...AC0	72 us

Note:

1. Make sure that ST7920 is not in busy state by reading the busy flag before sending instruction or data. If using delay loop instead, please make sure the delay time is enough. Please refer to the instruction execution time.
2. "RE" is the selection bit of basic and extended instruction set. After setting the RE bit, the value will be kept. So that the software doesn't have to set RE every time when using the same instruction set.

ST7920

Initial Setting (Register flag) (RE=0: basic instruction)

Inst.	Code										Description
	RS	RW	DB7	DB6	DB5	DB4	DB3	DB2	DB1	DB0	
Entry Mode Set	0	0	0	0	0	0	0	1	I/D	S	Cursor move to right ,DDRAM address counter (AC) plus 1
									1	0	
Display Control	0	0	0	0	0	0	1	D	C	B	Display, cursor and blink are ALL OFF
								0	0	0	
CURSOR DISPLAY SHIFT	0	0	0	0	0	1	S/C	R/L	X	X	No cursor or display shift operation
							X	X			
FUNCTION SET	0	0	0	0	1	DL	X	0 RE	X	X	8-bit MPU interface , basic instruction set
					1			0			

Initial Setting (Register flag) (RE=1: extended instruction set)

Inst.	Code										Description
	RS	RW	DB7	DB6	DB5	DB4	DB3	DB2	DB1	DB0	
SCROLL OR RAM ADDR. SELECT	0	0	0	0	0	0	0	0	1	SR	Allow vertical scroll or set CGRAM address
										0	
REVERSE	0	0	0	0	0	0	0	1	R1	R0	Begin with normal and toggle to reverse
									0	0	
EXTENDED FUNCTION SET	0	0	0	0	1	DL	X	1 RE	G	0	Graphic display OFF
									0		

ST7920

Description of basic instruction set

I Display Clear

	RS	RW	DB7	DB6	DB5	DB4	DB3	DB2	DB1	DB0
Code	0	0	0	0	0	0	0	0	0	1

This instruction will change the following items:

1. Fill DDRAM with "20H"(space code).
2. Set DDRAM address counter (AC) to"00H".
3. Set Entry Mode I/D bit to be "1". Cursor moves right and AC adds 1 after write or read operation.

I Return Home

	RS	RW	DB7	DB6	DB5	DB4	DB3	DB2	DB1	DB0
Code	0	0	0	0	0	0	0	0	1	X

Set address counter (AC) to "00H". Cursor moves to origin. Then content of DDRAM is not changed.

I Entry Mode Set

	RS	RW	DB7	DB6	DB5	DB4	DB3	DB2	DB1	DB0
Code	0	0	0	0	0	0	0	1	I/D	S

Set the cursor movement and display shift direction when doing write or read operation.

I/D: Address Counter Control: (Increase/Decrease)

When I/D = "1", cursor moves right, address counter (AC) is increased by 1.

When I/D = "0", cursor moves left, address counter (AC) is decreased by 1.

S: Display Shift Control: (Shift Left/Right)

S	I/D	DESCRIPTION
H	H	Entire display shift left by 1
H	L	Entire display shift right by 1

ST7920

I Display Control

	RS	RW	DB7	DB6	DB5	DB4	DB3	DB2	DB1	DB0
Code	0	0	0	0	0	0	1	D	C	B

Controls display, cursor and blink ON/OFF.

D: Display ON/OFF control bit

When D = "1", display ON

When D = "0", display OFF, the content of DDRAM is not changed

C: Cursor ON/OFF control bit

When C = "1", cursor ON.

When C = "0", cursor OFF.

B: Character Blink ON/OFF control bit

When B = "1", cursor position blink ON. Then display data (character) in cursor position will blink.

When B = "0", cursor position blink OFF

I Cursor/Display Shift Control

	RS	RW	DB7	DB6	DB5	DB4	DB3	DB2	DB1	DB0
Code	0	0	0	0	0	1	S/C	R/L	X	X

This instruction configures the cursor moving direction or the display shifting direction. The content of DDRAM is not changed.

S/C	R/L	Description	AC Value
L	L	Cursor moves left by 1 position	AC=AC-1
L	H	Cursor moves right by 1 position	AC=AC+1
H	L	Display shift left by 1, cursor also follows to shift.	AC=AC
H	H	Display shift right by 1, cursor also follows to shift.	AC=AC

ST7920

I Function Set

	RS	RW	DB7	DB6	DB5	DB4	DB3	DB2	DB1	DB0
Code	0	0	0	0	1	DL	X	RE	X	X

DL: 4/8-bit interface control bit

When DL = "1", 8-bit MPU bus interface

When DL = "0", 4-bit MPU bus interface

RE: extended instruction set control bit

When RE = "1", extended instruction set

When RE = "0", basic instruction set

In same instruction cannot alter DL and RE at once. Make sure that change DL first then RE.

I Set CGRAM Address

	RS	RW	DB7	DB6	DB5	DB4	DB3	DB2	DB1	DB0
Code	0	0	0	1	AC5	AC4	AC3	AC2	AC1	AC0

Set CGRAM address into address counter (AC)

AC range is 00H...3FH

Make sure that in extended instruction SR=0 (scroll address or RAM address select)

I Set DDRAM Address

	RS	RW	DB7	DB6	DB5	DB4	DB3	DB2	DB1	DB0
Code	0	0	1	AC6	AC5	AC4	AC3	AC2	AC1	AC0

Set DDRAM address into address counter (AC).

First line AC range is 80H...8FH

Second line AC range is 90H...9FH

Third line AC range is A0H...AFH

Fourth line AC range is B0H...BFH

Please note that only 2 lines can be display with one ST7920.

I Read Busy Flag (BF) and Address

	RS	RW	DB7	DB6	DB5	DB4	DB3	DB2	DB1	DB0
Code	0	1	BF	AC6	AC5	AC4	AC3	AC2	AC1	AC0

Read busy flag (BF) can check whether the internal operation is finished or not. At the same time, the value of address counter (AC) is also read. When BF = "1", further instruction(s) will not be accepted until BF = "0".

ST7920

I Write Data to RAM

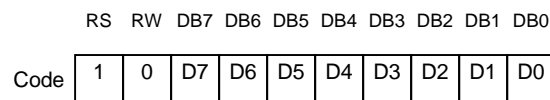

Write data to the internal RAM and increase/decrease the (AC) by 1

Each RAM address (CGRAM, DDRAM and GDRAM...) must write 2 consecutive bytes for 16-bit data. After receiving the second byte, the address counter will increase or decrease by 1 according to the entry mode set control bit.

I Read RAM Data

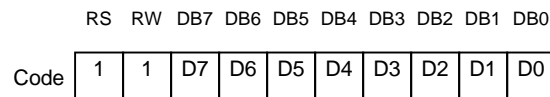

Read data from the internal RAM and increase/decrease the (AC) by 1

After the operation mode changed to Read (CGRAM, DDRAM and GDRAM...), a "Dummy Read" is required. There is no need to add a "Dummy Read" for the following bytes unless a new address set instruction is issued.

ST7920

Description of extended instruction set

I Standby

	RS	RW	DB7	DB6	DB5	DB4	DB3	DB2	DB1	DB0
Code	0	0	0	0	0	0	0	0	0	1

This Instruction will set ST7920 entering the standby mode. Any other instruction follows this instruction will terminate the standby mode.

The content of DDRAM remains the same.

I Vertical Scroll or RAM Address Select

	RS	RW	DB7	DB6	DB5	DB4	DB3	DB2	DB1	DB0
Code	0	0	0	0	0	0	0	0	1	SR

When SR = "1", the Vertical Scroll mode is enabled.

When SR = "0", "Set CGRAM Address" instruction (**basic instruction**) is enabled.

I Reverse

	RS	RW	DB7	DB6	DB5	DB4	DB3	DB2	DB1	DB0
Code	0	0	0	0	0	0	0	1	R1	R0

Select 1 out of 4 lines to reverse the display and to toggle the reverse condition by repeating this instruction.

R1, R0 initial vale is 00. The first time issuing this instruction, the display will be reversed while the second time will return the display become normal.

R1	R0	Description
L	L	First line normal or reverse
L	H	Second line normal or reverse
H	L	Third line normal or reverse
H	H	Fourth line normal or reverse

Please note that only 2 lines out of 4 lines of display data can be displayed with one ST7920.

ST7920

I Extended Function Set

	RS	RW	DB7	DB6	DB5	DB4	DB3	DB2	DB1	DB0
Code	0	0	0	0	1	DL	X	RE	G	X

DL: 4/8-bit interface control bit

When DL = "1", 8-bit MPU interface.

When DL = "0", 4-bit MPU interface.

RE: extended instruction set control bit

When RE = "1", extended instruction set

When RE = "0", basic instruction set

G: Graphic display control bit

When G = "1", Graphic Display ON

When G = "0", Graphic Display OFF

In same instruction cannot alter DL, RE and G at once. Make sure that change DL or G first and then RE.

I Set Scroll Address

	RS	RW	DB7	DB6	DB5	DB4	DB3	DB2	DB1	DB0
Code	0	0	0	1	AC5	AC4	AC3	AC2	AC1	AC0

SR=1: AC5~AC0 is vertical scroll displacement address

I Set Graphic RAM Address

	RS	RW	DB7	DB6	DB5	DB4	DB3	DB2	DB1	DB0
Code	0	0	1	0	AC5	AC4	AC3	AC2	AC1	AC0

	RS	RW	DB7	DB6	DB5	DB4	DB3	DB2	DB1	DB0
Code	0	0	1	0	0	0	AC3	AC2	AC1	AC0

Set GDRAM address into address counter (AC). This is a 2-byte instruction.

The first instruction sets the vertical address while the second one sets the horizontal address (write 2 consecutive bytes to complete the vertical and horizontal address setting).

Vertical address range is AC5...AC0

Horizontal address range is AC3...AC0

The address counter (AC) of graphic RAM (GRAM) will be increased automatically after the vertical and horizontal addresses are set. After horizontal address is increased upto 0FH, it will automatically return to 00H.

However, the vertical address will not increase as the result of the same action.

ST7920

Parallel interface:

ST7920 is in parallel mode by pulling up PSB pin. ST7920 can select 8-bit or 4-bit bus interface by setting the DL control bit in "Function Set" instruction. MPU can control RS, RW, E and DB0...DB7 pins to complete the data transmission.

In 4-bit transfer mode, every 8-bit data or instruction is separated into 2 parts. The higher 4 bits (bit-7~bit-4) data will be transferred first through data pins (DB7~DB4). The lower 4 bits (bit-3~bit-0) data will be transferred second through data pins (DB7~DB4). The (DB3~DB0) data pins are not used during 4-bit transfer mode.

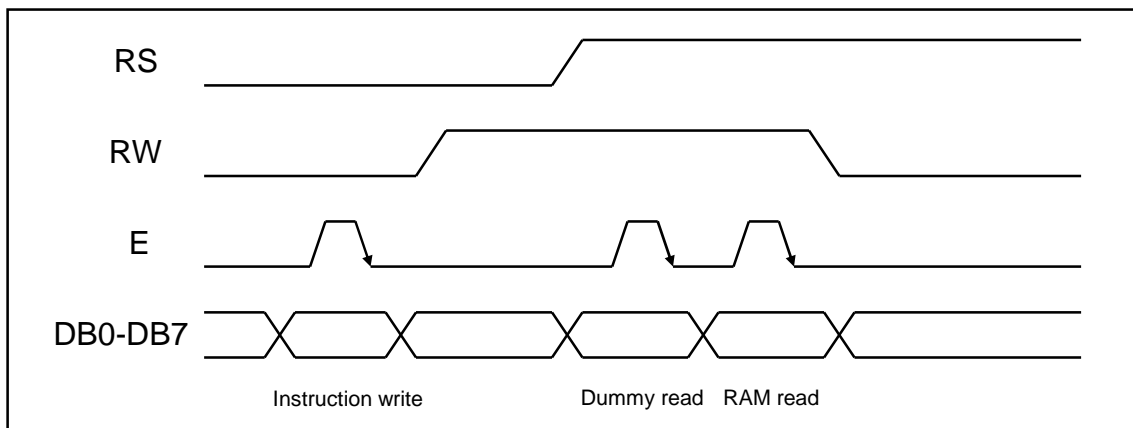

Timing Diagram of 8-bit Parallel Bus Mode Data Transfer

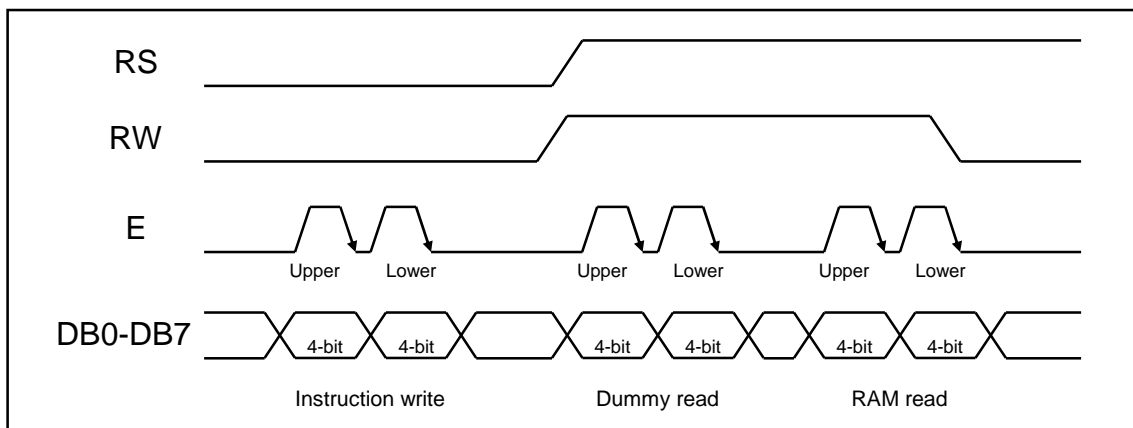

Timing Diagram of 4-bit Parallel Bus Mode Data Transfer

ST7920

Serial interface:

ST7920 is in serial interface mode when pulling down PSB pin. Two pins (SCLK and SID) are used to complete the data transfer. Only write data is available in the serial interface mode.

When chip select (CS) is low, ST7920 serial clock counter and serial data will be reset. Serial transfer counter is set to the first bit and data register is cleared. After CS is "L", any further change on SID or SCLK is not allowed. It is recommended to keep SCLK at "L" and SID at the last status before set CS to "L". For a minimal system with only one ST7920 and one MPU, only SCLK and SID pins are necessary. CS pin should pull to high.

ST7920's serial clock (SCLK) is asynchronous to the internal clock and is generated by MPU. When multiple instruction/data is transferred, the instruction execution time must be considered. MPU must wait till the previous instruction is finished and then send the next instruction. ST7920 has no internal instruction buffer area.

When starting a transmission, a start byte is required. It consists of 5 consecutive "1" (sync character). Serial transfer counter will be reset and synchronized. Followed by 2-bit flag that indicates: read/write (RW) and register/data selected (RS) operation. Last 4 bits are filled by "0".

After receiving the sync character, RW and RS bits, every 8 bits instruction/data will be separated into 2 groups. Higher 4 bits (DB7~DB4) will be placed in the first section followed by 4 "0"s. And lower 4 bits (DB3~DB0) will be placed in the second section followed by 4 "0"s.

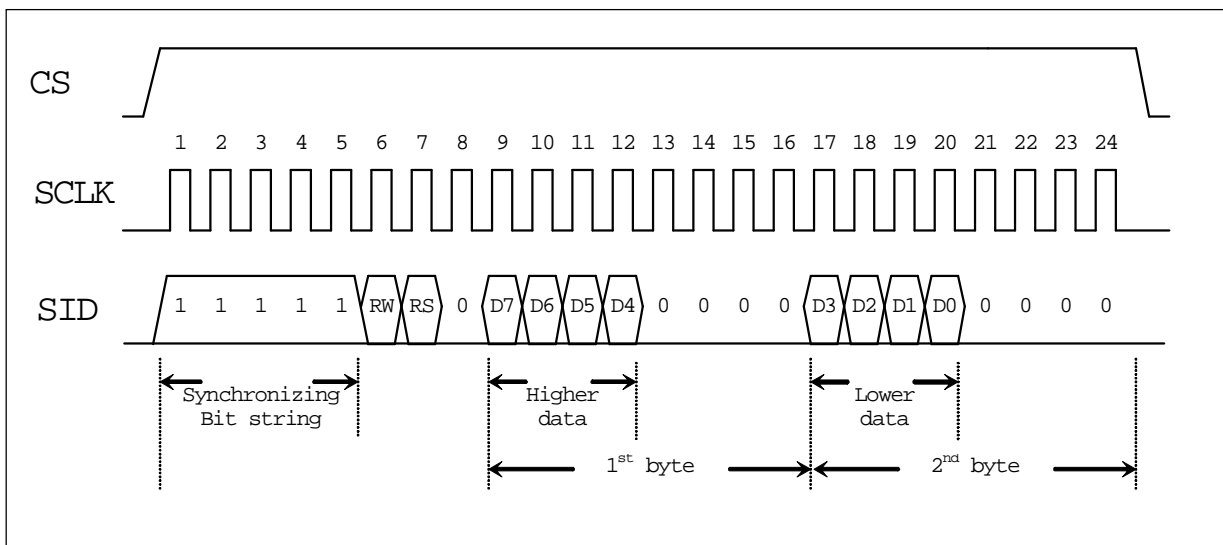

Timing Diagram of Serial Mode Data Transfer

ST7920

Application circuit for testing CGROM and HCGROM:

We can use the function of "CHECK SUM" to check the CGROM is right or error.

See the following notes: Using IC Pad (Pin4↔ CLK, Pin5↔ TT1, Pin6↔ TT2) to do the "CHECK SUM" function. The application circuit is at Page49.

Timing Diagram for checking CGROM (TT1=0, TT2=1)

The ST7920 check sum process: (DDRAM must be cleared by 0x00 before this process)

In the first place: Resetting the internal counter (set TT1 and TT2 to Height)

In the second place: Setting CGROM mode (set TT1 to Low, TT2 to Height).

In the third place: CLK starts to count 655362 times.

In the final place: Finishing the counting, read the last four bytes to CHECK SUM (reading only when the CLK is Height).

ST7920 check sum circuit: Data is available when CLK is height; if CLK is low then the data is always FFH. The last four bytes are Y0, Y1, Y2, and Y3.

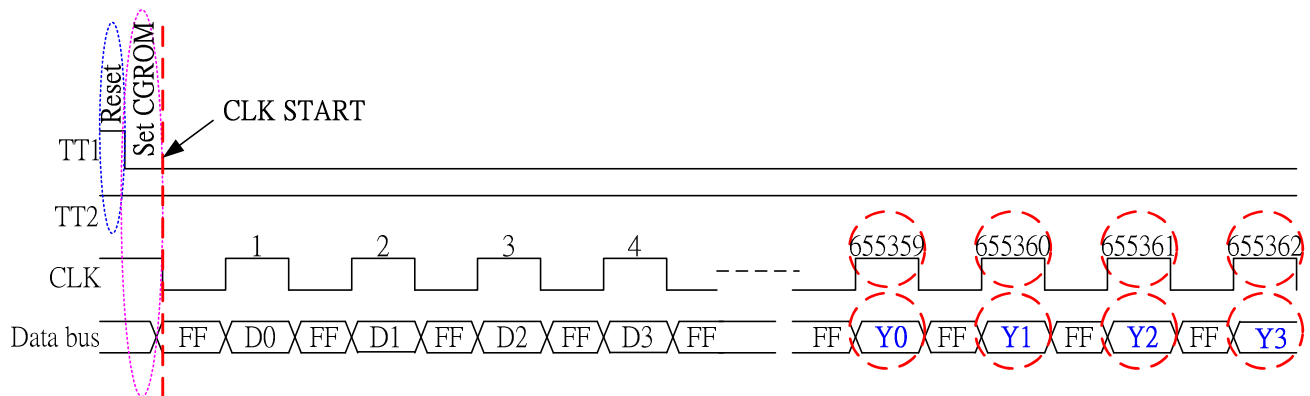

The fastest execution time is: $t_{CYC}=1\mu s$ (1MHz at 5V).

The table below is a comparing table of CGROM for different versions.

	Version (Font)	CGROM Last four bytes			
		Y0	Y1	Y2	Y3
1	Big5 (0A)	38	88	CC	F1
2	GB (0B)	9D	81	79	29
3	0C	FD	6F	B5	85

ST7920

Timing Diagram for checking HCGROM (TT1=1, TT2=0)

The ST7920 check sum process: (DDRAM must be cleared by 0x00 before this process)

In the first place: Resetting the internal counter (set TT1 and TT2 to Height)

In the second place: Setting CGROM mode (set TT1 to Height, TT2 to Low).

In the third place: CLK starts to count 10242 times.

In the final place: Finishing the counting, read the last four bytes to CHECK SUM (reading only when the CLK is Height).

ST7920 check sum circuit: Data is available when CLK is height; if CLK is low then the data is always FFH. The last four bytes are Y0, Y1, Y2, and Y3.

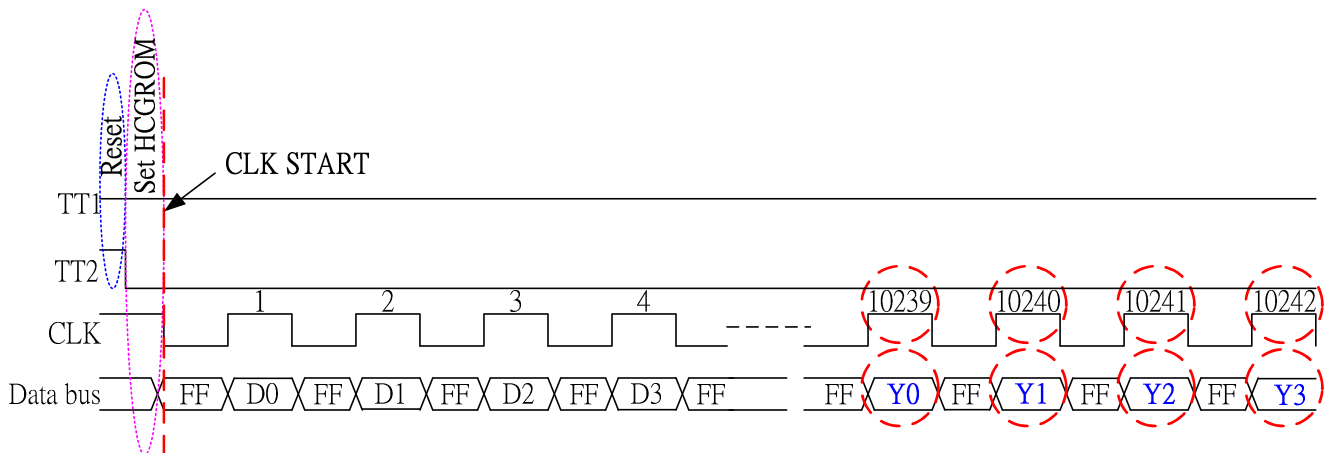

The fastest execution time is: $t_{CYC}=2\mu s$ (0.5MHz at 5V).

The table below is a comparing table of HCGROM for different versions.

	Version (Font)	HCGROM last four bytes			
		Y0	Y1	Y2	Y3
1	Big5 (0A)	B5	11	B5	11
2	GB (0B)	B5	11	B5	11
3	0C	B5	11	B5	11

ST7920

Testing Step:

1. Clear whole DDRAM area by writing data 0x00.
2. Composing TT1 and TT2 to make the 'Reset' action, and clear the internal counter.
3. Selecting the test mode by setting TT1 and TT2 (CGROM or HCGROM).
4. After setp1 and setp2, entering some impulse signals through Pin4 (CLK).
5. Reading the CHECK SUM data through D0 to D7.
6. Comparing CHECK SUM with the Code Table (upper table) to check if the data is correct or not.

TT1	TT2	No. of counts	Status
1	1	--	RESET
0	1	655362	CGROM
1	0	10242	HGROM

Test process flow:

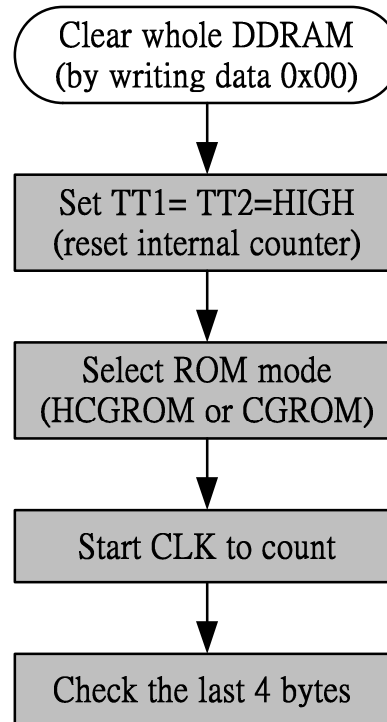

ST7920

8051 CGROM、HCGROM illustrative test program

```

;*****
;*   CHECK_ROM   *
;*****
;*****
;*   Definition of outside Pin *
;*****
CLK    REG    P3.5      ;
TT1    REG    P3.0      ;
TT2    REG    P3.1      ;
TT3    REG    P3.2      ;CHECK CGROM FLAG
TT4    REG    P3.3      ;CHECK HCGROM FLAG
TT5    REG    P3.4      ;ERROR FLAG
;*****
;*   Definition of internal RAM *
;*****
STACK  EQU    6FH      ;
FUNC   EQU    20H      ;
;*****
;       Interrupt set *
;*****
ORG    00H      ;
AJMP   RESET    ;
;*****
;*   PROGRAM START *
;*****
RESET:  MOV    SP, #STACK ;
        MOV    P1, #FFH  ;
        MOV    P3, #FFH  ;
;*****
;*   CHECK_CGROM *
;*****
;*****
;*   Initial DDRAM *
;*****
CALL   WR0x00    ;Write 0x00 to whole DDRAM
;*****
;*   Initial setting *
;*****
CGROM  SETB   TT1      ;
        SETB   TT2      ;TT1,TT2 SET HIGH (RESET)
        CALL   DELAY_100US ;Wait Reset 100us
        CLR    TT1      ;TT1=LOW TT2=HIGH ( CHECK CGROM)
        SETB   CLK      ;
        CALL   DELAY_100US ;
;*****
;*   start counter *
;*****
        MOV    R3, #9    ;
CN4:   MOV    R2, #0     ;<---- |
CN3:   MOV    R1, #0     ;      |
CN2:   CLR    CLK       ;      |
        SETB   CLK       ;      |
        DJNZ  R1, CN2    ;      |
        DJNZ  R2, CN3    ;      |
        DJNZ  R3, CN4    ;      |
;*****
        MOV    R3, #0    ;      |
CN5:   MOV    R2, #255   ;      |
CN6:   CLR    CLK       ;      |
        SETB   CLK       ;      |
        DJNZ  R2, CN6    ;      |
        DJNZ  R3, CN5    ;      |
;*****

```

ST7920

```

      MDV    R3, #63          ;
CN7:  MDV    R2, #2          ;
CN8:  MDV    R1, #2          ;
CN9:  CLR    CLK             ;
      SETB   CLK             ;
      DJNZ   R1, CN9         ;
      DJNZ   R2, CN8         ;
      DJNZ   R3, CN7         ;
      CLR    CLK             ;
      SETB   CLK             ;
      CLR    CLK             ;
      SETB   CLK             ;<---- Counter 655356
;-----;
      CLR    CLK             ;Counter 655357
      SETB   CLK             ;
      MDV    A, P1           ;A=Y0
      CJNE   A, #FDH, ERRORC ;COMPARE Y0 DATA
      CLR    CLK             ;Counter 655358
      SETB   CLK             ;
      MDV    A, P1           ;A=Y1
      CJNE   A, #6FH, ERRORC ;COMPARE Y1 DATA
      CLR    CLK             ;Counter 655359
      SETB   CLK             ;
      MDV    A, P1           ;A=Y2
      CJNE   A, #B5H, ERRORC ;COMPARE Y2 DATA

      CLR    CLK             ;Counter 655360
      SETB   CLK             ;
      MDV    A, P1           ;A=Y3
      CJNE   A, #85H, ERRORC ;COMPARE Y3 DATA
      CLR    CLK             ;
      CLR    TT3             ;IF OK CLR TT3
      CALL   HCGROM          ;
ERRORC:
      CLR    TT5             ;IF CGROM CHECK ERROR CLR TT5
;-----;
;*****;
; *      CHECK_HCGROM      *;
;*****;
;*****;
; *      Initial setting  *;
;*****;
;*****;
HCGROM SETB   TT1             ;
      SETB   TT2             ;TT1, TT2 SET HIGH (RESET)
      CALL   DELAY_100US     ;Wait Reset 100us
      CLR    TT2             ;TT2=LOW TT1=HIGH ( CHECK HCGROM)
      SETB   CLK             ;
      CALL   DELAY_100US     ;
;*****;
; *      start counter    *;
;*****;
;*****;
      MDV    R3, #9          ;
N4:  MDV    R2, #32         ;<----
N3:  MDV    R1, #32         ;
N2:  CLR    CLK             ;
      SETB   CLK             ;
      DJNZ   R1, N2         ;
      DJNZ   R2, N3         ;
      DJNZ   R3, N4         ;
;
      MDV    R3, #32         ;
N5:  MDV    R2, #31         ;
N6:  CLR    CLK             ;
      SETB   CLK             ;
      DJNZ   R2, N6         ;
      DJNZ   R3, N5         ;
;
      MDV    R2, #30         ;

```

ST7920

```

N7:   CLR   CLK           ;   |
      SETB  CLK           ;   |
      DJNZ  R2, N7        ;   |
;-----<----- Counter 10236
      CLR   CLK           ;Counter 10237
      SETB  CLK           ;
      MOV   A, P1         ;A=Y0
      CJNE  A, #B5H, ERROR ;COMPARE Y0 DATA
      CLR   CLK           ;Counter 10238
      SETB  CLK           ;
      MOV   A, P1         ;A=Y1
      CJNE  A, #11H, ERROR ;COMPARE Y1 DATA
      CLR   CLK           ;Counter 10239
      SETB  CLK           ;
      MOV   A, P1         ;A=Y2
      CJNE  A, #B5H, ERROR ;COMPARE Y2 DATA
      CLR   CLK           ;Counter 10240
      SETB  CLK           ;
      MOV   A, P1         ;A=Y3
      CJNE  A, #11H, ERROR ;COMPARE Y3 DATA
      CLR   CLK           ;
      CLR   TT4           ;IF HCGROM CHECK OK THEN CLR TT4
      AJMP  S             ;
ERROR:
      CLR   TT5           ;IF HCGROM CHECK ERROR THEN CLR TT5
      AJMP  S             ;
;*****
; *      DELAY TIME 100US      *
;*****
DELAY_100US
DEL_10  MOV   R6, #5
DEL_9   MOV   R7, #3
        DJNZ  R7, S
        DJNZ  R6, DEL_9
        RET
END

```

ST7920

8-bit interface:

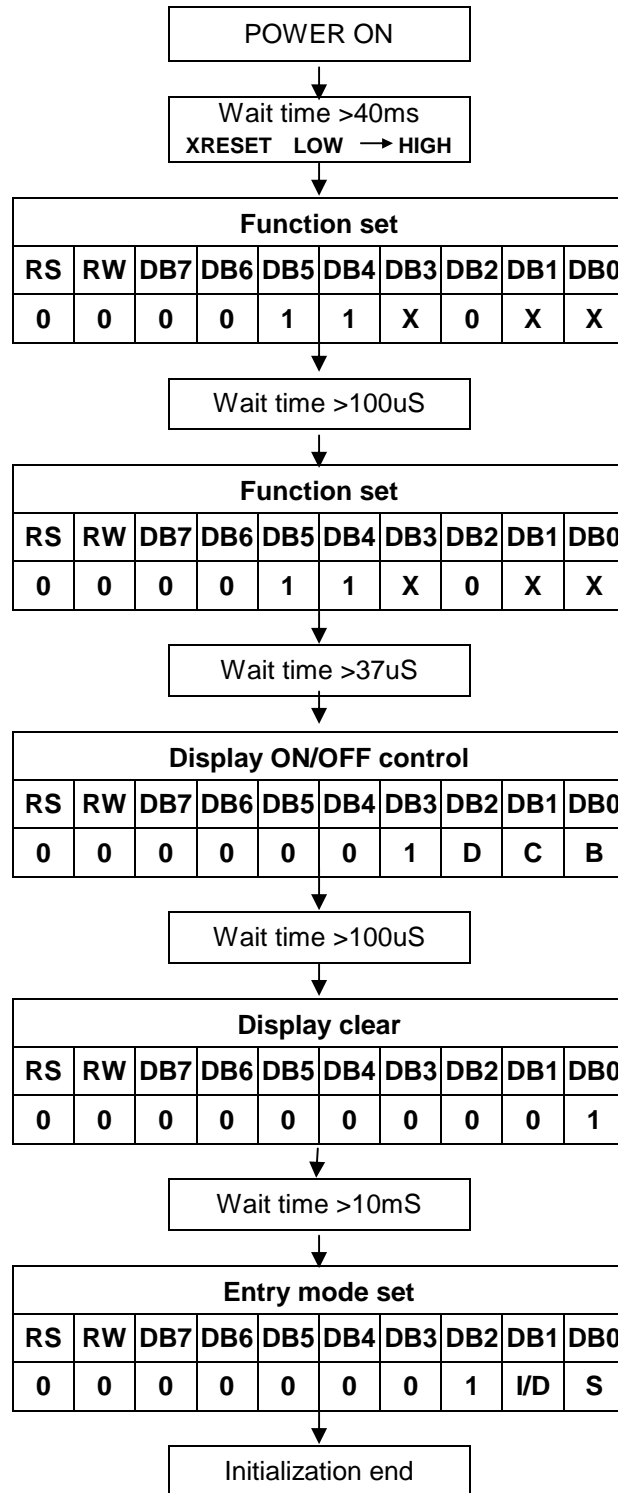

ST7920

4-bit interface:

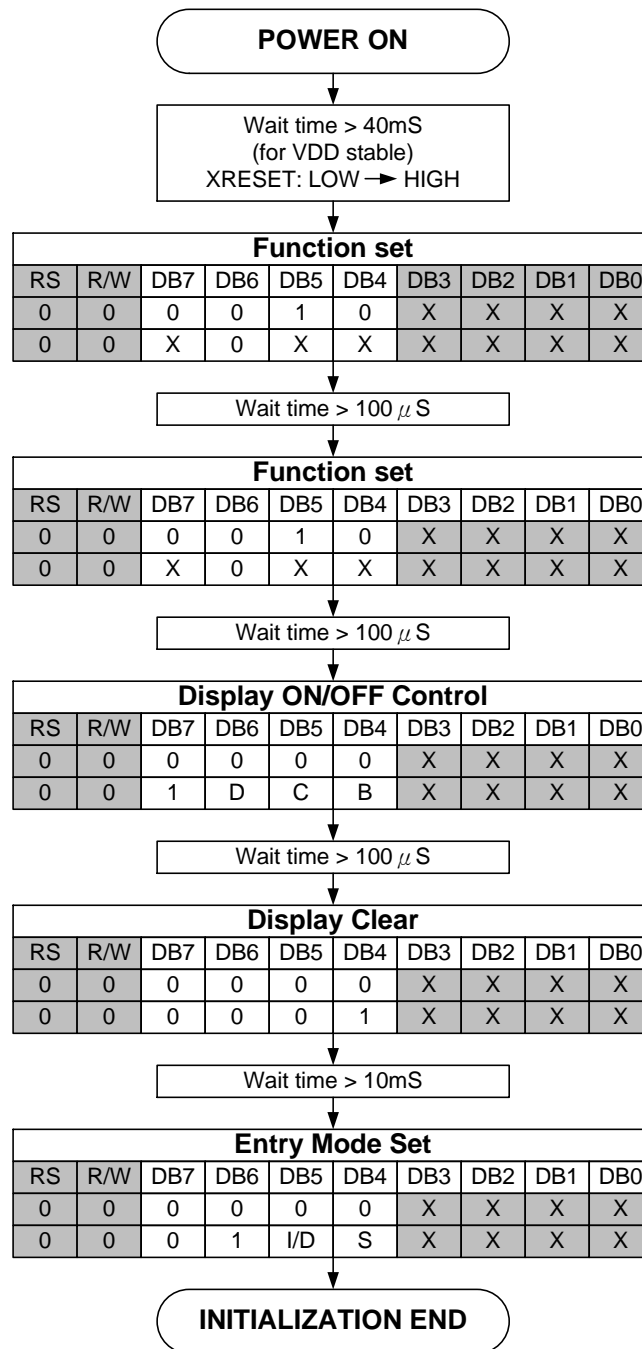

ST7920

Built in voltage booster

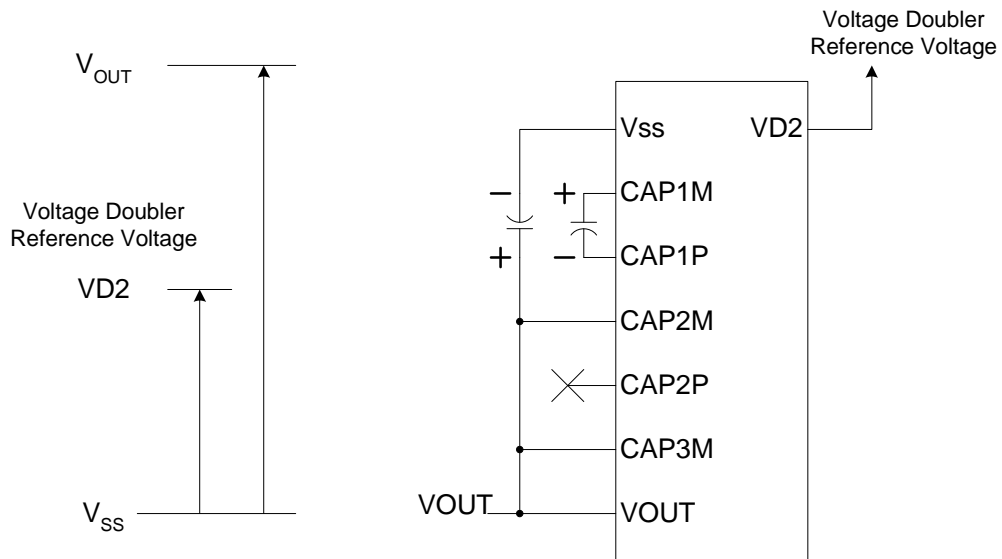

External reset timing

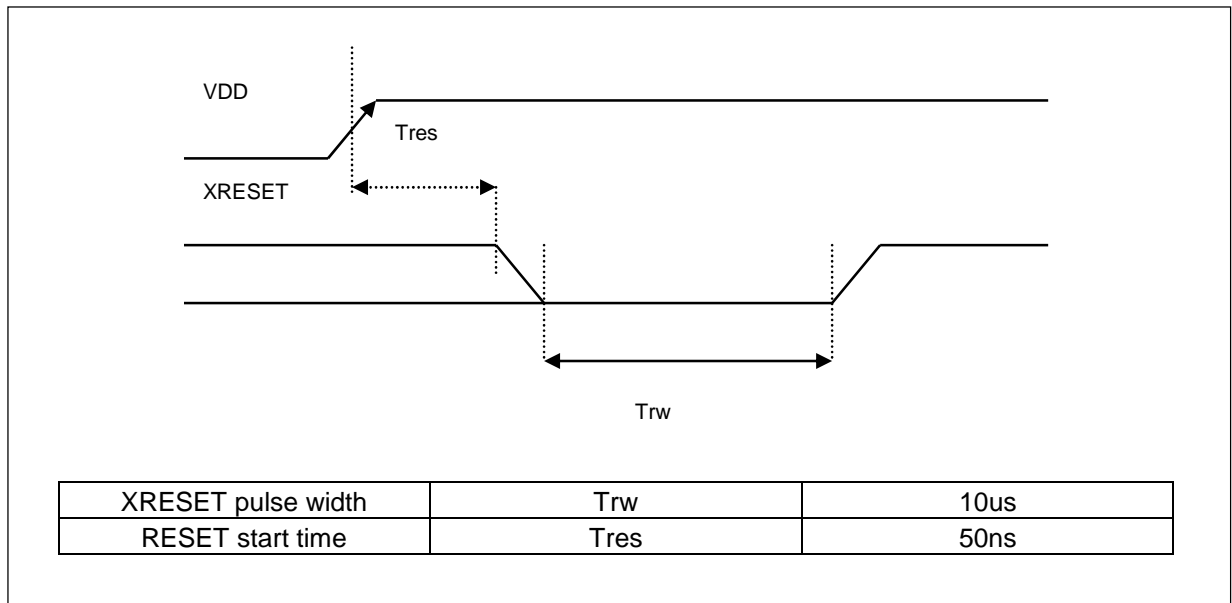

ST7920

LCD driving wave form (1/33 duty, 1/5 bias)

When oscillation frequency is 540KHZ, 1 clock cycle time = 1.85us

1 frame = 1.85us x 300 x 33 = 18315us=18.3ms

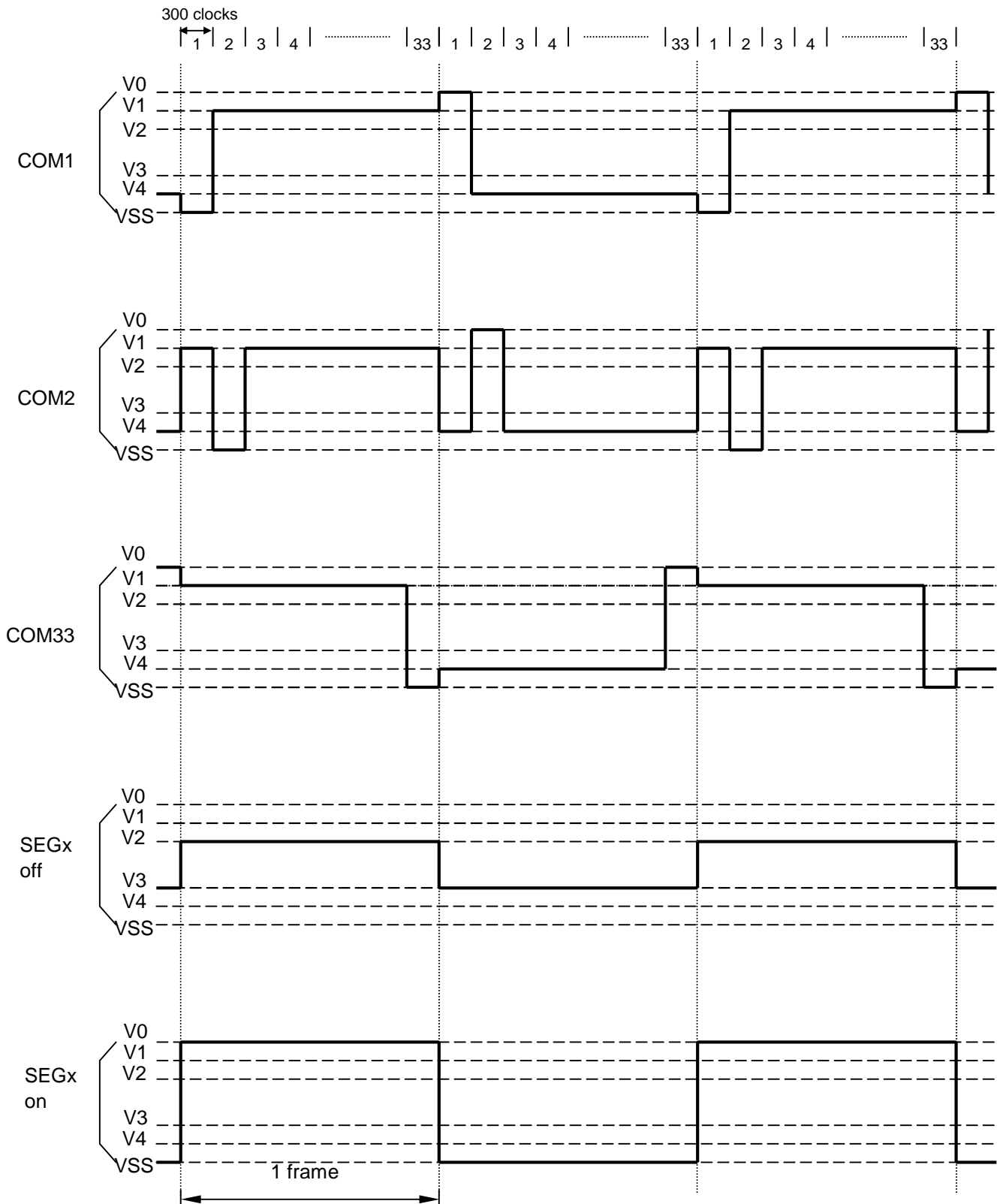

ST7920

Absolute Maximum Ratings

Characteristics	Symbol	Value
Power Supply Voltage	V_{DD}	-0.3V to +6.0V
LCD Driver Voltage	V_{LCD} or V_0	-0.3V to +7.0V
Voltage Doubler Output	V_{OUT}	-0.3V to +7.0V
Input Voltage	V_{IN}	-0.3V to $V_{DD}+0.3V$
Operating Temperature	T_A	-30°C to +85°C
Storage Temperature	T_{STO}	-65°C to +150°C

DC Characteristics ($T_A = -30^\circ\text{C} \sim 85^\circ\text{C}$, $V_{DD} = 2.7\text{ V} - 4.5\text{ V}$)

Symbol	Characteristics	Test Condition	Min.	Typ.	Max.	Unit
V_{DD}	Operating Voltage	-	2.7	-	5.5	V
V_{LCD}	LCD Voltage	V_0-V_{SS}	3.0	-	7	V
I_{CC}	Power Supply Current	$f_{OSC} = 530\text{KHz}$, $V_{DD}=3.0\text{V}$ $R_f=18\text{K}\Omega$	-	0.20	0.45	mA
V_{IH1}	Input High Voltage (Except OSC1)	-	$0.7V_{DD}$	-	V_{DD}	V
V_{IL1}	Input Low Voltage (Except OSC1)	-	-0.3	-	0.6	V
V_{IH2}	Input High Voltage (OSC1)	-	$V_{DD} - 1$	-	V_{DD}	V
V_{IL2}	Input Low Voltage (OSC1)	-	-	-	1.0	V
V_{OH1}	Output High Voltage (DB0 - DB7)	$I_{OH} = -0.1\text{mA}$	$0.8V_{DD}$	-	V_{DD}	V
V_{OL1}	Output Low Voltage (DB0 - DB7)	$I_{OL} = 0.1\text{mA}$	-	-	0.1	V
V_{OH2}	Output High Voltage (Except DB0 - DB7)	$I_{OH} = -0.04\text{mA}$	$0.8V_{DD}$	-	V_{DD}	V
V_{OL2}	Output Low Voltage (Except DB0 - DB7)	$I_{OL} = 0.04\text{mA}$	-	-	$0.1V_{DD}$	V
I_{LEAK}	Input Leakage Current	$V_{IN} = 0\text{V to } V_{DD}$	-1	-	1	μA
I_{PUP}	Pull Up MOS Current	$V_{DD} = 3\text{V}$	22	27	32	μA

ST7920

DC Characteristics ($T_A = -30^{\circ}\text{C} \sim 85^{\circ}\text{C}$, $V_{DD} = 4.5\text{ V} - 5.5\text{ V}$)

Symbol	Characteristics	Test Condition	Min.	Typ.	Max.	Unit
V_{DD}	Operating Voltage	-	4.5	-	5.5	V
V_{LCD}	LCD Voltage	$V_0 - V_{SS}$	3.0	-	7	V
I_{CC}	Power Supply Current	$f_{OSC} = 540\text{KHz}$, $V_{DD}=5\text{V}$ $R_f=33\text{K}\Omega$	-	0.45	0.75	mA
V_{IH1}	Input High Voltage (Except OSC1)	-	$0.7V_{DD}$	-	V_{DD}	V
V_{IL1}	Input Low Voltage (Except OSC1)	-	-0.3	-	0.6	V
V_{IH2}	Input High Voltage (OSC1)	-	$V_{DD}-1$	-	V_{DD}	V
V_{IL2}	Input Low Voltage (OSC1)	-	-	-	1.0	V
V_{OH1}	Output High Voltage (DB0 - DB7)	$I_{OH} = -0.1\text{mA}$	$0.8V_{DD}$	-	V_{DD}	V
V_{OL1}	Output Low Voltage (DB0 - DB7)	$I_{OL} = 0.1\text{mA}$	-	-	0.4	V
V_{OH2}	Output High Voltage (Except DB0 - DB7)	$I_{OH} = -0.04\text{mA}$	$0.8V_{DD}$	-	V_{DD}	V
V_{OL2}	Output Low Voltage (Except DB0 - DB7)	$I_{OL} = 0.04\text{mA}$	-	-	$0.1V_{DD}$	V
I_{LEAK}	Input Leakage Current	$V_{IN} = 0\text{V to } V_{DD}$	-1	-	1	μA
I_{PUP}	Pull Up MOS Current	$V_{DD} = 5\text{V}$	75	80	85	μA

ST7920

AC Characteristics ($T_A = -30^{\circ}\text{C} \sim 85^{\circ}\text{C}$, $V_{DD} = 4.5\text{V}$) Parallel Mode Interface

Symbol	Characteristics	Test Condition	Min.	Typ.	Max.	Unit
<i>Internal Clock Operation</i>						
f_{OSC}	OSC Frequency	R = 33K Ω	480	540	600	KHz
<i>External Clock Operation</i>						
f_{EX}	External Frequency	-	480	540	600	KHz
	Duty Cycle	-	45	50	55	%
$T_{\text{R}}, T_{\text{F}}$	Rise/Fall Time	-	-	-	0.2	μs
<i>Write Mode (Writing data from MPU to ST7920)</i>						
T_{C}	Enable Cycle Time	Pin E	1200	-	-	ns
T_{PW}	Enable Pulse Width	Pin E	140	-	-	ns
$T_{\text{R}}, T_{\text{F}}$	Enable Rise/Fall Time	Pin E	-	-	25	ns
T_{AS}	Address Setup Time	Pins: RS, RW, E	10	-	-	ns
T_{AH}	Address Hold Time	Pins: RS, RW, E	20	-	-	ns
T_{DSW}	Data Setup Time	Pins: DB0 - DB7	40	-	-	ns
T_{H}	Data Hold Time	Pins: DB0 - DB7	20	-	-	ns
<i>Read Mode (Reading Data from ST7920 to MPU)</i>						
T_{C}	Enable Cycle Time	Pin E	1200	-	-	ns
T_{PW}	Enable Pulse Width	Pin E	140	-	-	ns
$T_{\text{R}}, T_{\text{F}}$	Enable Rise/Fall Time	Pin E	-	-	25	ns
T_{AS}	Address Setup Time	Pins: RS, RW, E	10	-	-	ns
T_{AH}	Address Hold Time	Pins: RS, RW, E	20	-	-	ns
T_{DDR}	Data Delay Time	Pins: DB0 - DB7	-	-	100	ns
T_{H}	Data Hold Time	Pins: DB0 - DB7	20	-	-	ns
<i>Interface Mode with LCD Driver(ST7921)</i>						
T_{CWH}	Clock Pulse with High	Pins: CL1, CL2	800	-	-	ns
T_{CWL}	Clock Pulse with Low	Pins: CL1, CL2	800	-	-	ns
T_{CST}	Clock Setup Time	Pins: CL1, CL2	500	-	-	ns
T_{SU}	Data Setup Time	Pin: D	300	-	-	ns
T_{DH}	Data Hold Time	Pin: D	300	-	-	ns
T_{DM}	M Delay Time	Pin: M	-1000	-	1000	ns

ST7920

AC Characteristics ($T_A = -30^{\circ}\text{C} \sim 85^{\circ}\text{C}$, $V_{DD} = 2.7\text{V}$) Parallel Mode Interface

Symbol	Characteristics	Test Condition	Min.	Typ.	Max.	Unit
<i>Internal Clock Operation</i>						
f_{OSC}	OSC Frequency	R = 18K Ω	470	530	590	KHz
<i>External Clock Operation</i>						
f_{EX}	External Frequency	-	470	530	590	KHz
	Duty Cycle	-	45	50	55	%
$T_{\text{R}}, T_{\text{F}}$	Rise/Fall Time	-	-	-	0.2	μs
<i>Write Mode (Writing data from MPU to ST7920)</i>						
T_{C}	Enable Cycle Time	Pin E	1800	-	-	ns
T_{PW}	Enable Pulse Width	Pin E	160	-	-	ns
$T_{\text{R}}, T_{\text{F}}$	Enable Rise/Fall Time	Pin E	-	-	25	ns
T_{AS}	Address Setup Time	Pins: RS,RW,E	10	-	-	ns
T_{AH}	Address Hold Time	Pins: RS,RW,E	20	-	-	ns
T_{DSW}	Data Setup Time	Pins: DB0 - DB7	40	-	-	ns
T_{H}	Data Hold Time	Pins: DB0 - DB7	20	-	-	ns
<i>Read Mode (Reading Data from ST7920 to MPU)</i>						
T_{C}	Enable Cycle Time	Pin E	1800	-	-	ns
T_{PW}	Enable Pulse Width	Pin E	320	-	-	ns
$T_{\text{R}}, T_{\text{F}}$	Enable Rise/Fall Time	Pin E	-	-	25	ns
T_{AS}	Address Setup Time	Pins: RS,RW,E	10	-	-	ns
T_{AH}	Address Hold Time	Pins: RS,RW,E	20	-	-	ns
T_{DDR}	Data Delay Time	Pins: DB0 - DB7	-	-	260	ns
T_{H}	Data Hold Time	Pins: DB0 - DB7	20	-	-	ns
<i>Interface Mode with LCD Driver(ST7921)</i>						
T_{CWH}	Clock Pulse with High	Pins: CL1, CL2	800	-	-	ns
T_{CWL}	Clock Pulse with Low	Pins: CL1, CL2	800	-	-	ns
T_{CST}	Clock Setup Time	Pins: CL1, CL2	500	-	-	ns
T_{SU}	Data Setup Time	Pin: D	300	-	-	ns
T_{DH}	Data Hold Time	Pin: D	300	-	-	ns
T_{DM}	M Delay Time	Pin: M	-1000	-	1000	ns

ST7920

8-bit interface timing diagram

I MPU write data to ST7920

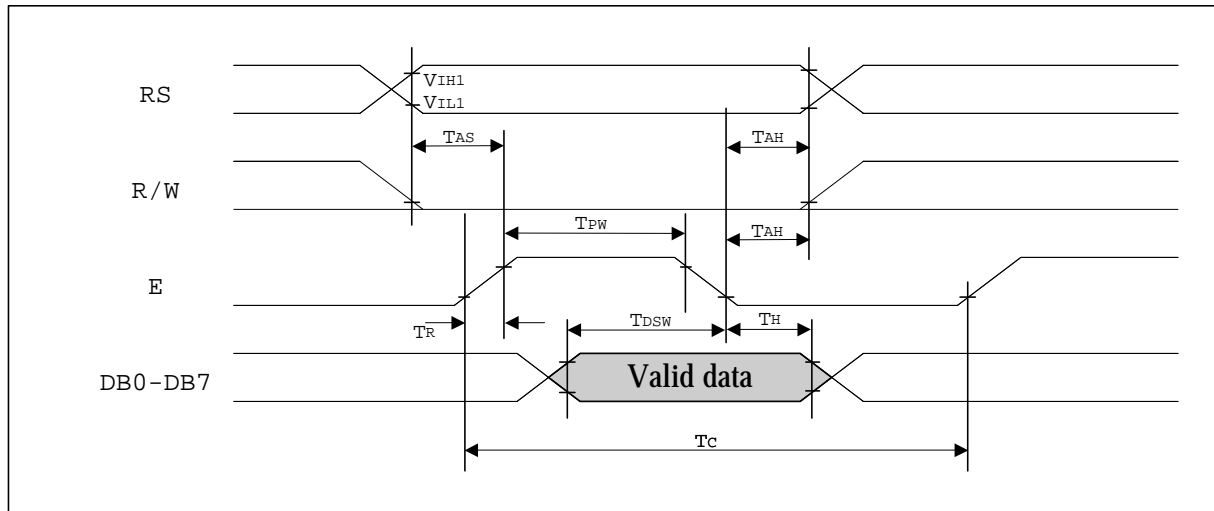

I MPU read data from ST7920

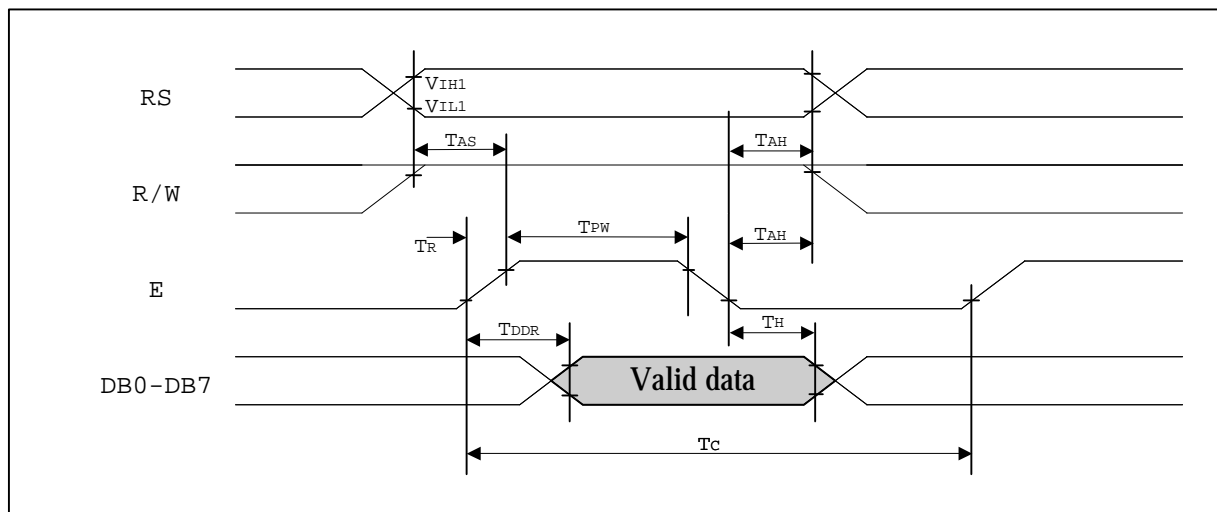

ST7920

AC Characteristics ($T_A = -30^{\circ}\text{C} \sim 85^{\circ}\text{C}$, $V_{DD} = 4.5\text{V}$) Serial Mode Interface

Symbol	Characteristics	Test Condition	Min.	Typ.	Max.	Unit
<i>Internal Clock Operation</i>						
f_{OSC}	OSC Frequency	R = 33K Ω	470	530	590	KHz
<i>External Clock Operation</i>						
f_{EX}	External Frequency	-	470	530	590	KHz
	Duty Cycle	-	45	50	55	%
$T_{\text{R}}, T_{\text{F}}$	Rise/Fall Time	-	-	-	0.2	μs
T_{SCYC}	Serial clock cycle	Pin E	400	-	-	ns
T_{SHW}	SCLK high pulse width	Pin E	200	-	-	ns
T_{SLW}	SCLK low pulse width	Pin E	200	-	-	ns
T_{SDS}	SID data setup time	Pins RW	40	-	-	ns
T_{SDH}	SID data hold time	Pins RW	40	-	-	ns
T_{CSS}	CS setup time	Pins RS	60	-	-	ns
T_{CSH}	CS hold time	Pins RS	60	-	-	ns

AC Characteristics ($T_A = -30^{\circ}\text{C} \sim 85^{\circ}\text{C}$, $V_{DD} = 2.7\text{V}$) Serial Mode Interface

Symbol	Characteristics	Test Condition	Min.	Typ.	Max.	Unit
<i>Internal Clock Operation</i>						
f_{OSC}	OSC Frequency	R = 18K Ω	470	530	590	KHz
<i>External Clock Operation</i>						
f_{EX}	External Frequency	-	470	530	590	KHz
	Duty Cycle	-	45	50	55	%
$T_{\text{R}}, T_{\text{F}}$	Rise/Fall Time	-	-	-	0.2	μs
T_{SCYC}	Serial clock cycle	Pin E	600	-	-	ns
T_{SHW}	SCLK high pulse width	Pin E	300	-	-	ns
T_{SLW}	SCLK low pulse width	Pin E	300	-	-	ns
T_{SDS}	SID data setup time	Pins RW	40	-	-	ns
T_{SDH}	SID data hold time	Pins RW	40	-	-	ns
T_{CSS}	CS setup time	Pins RS	60	-	-	ns
T_{CSH}	CS hold time	Pins RS	60	-	-	ns

ST7920

Serial interface timing diagram

I MPU write data to ST7920

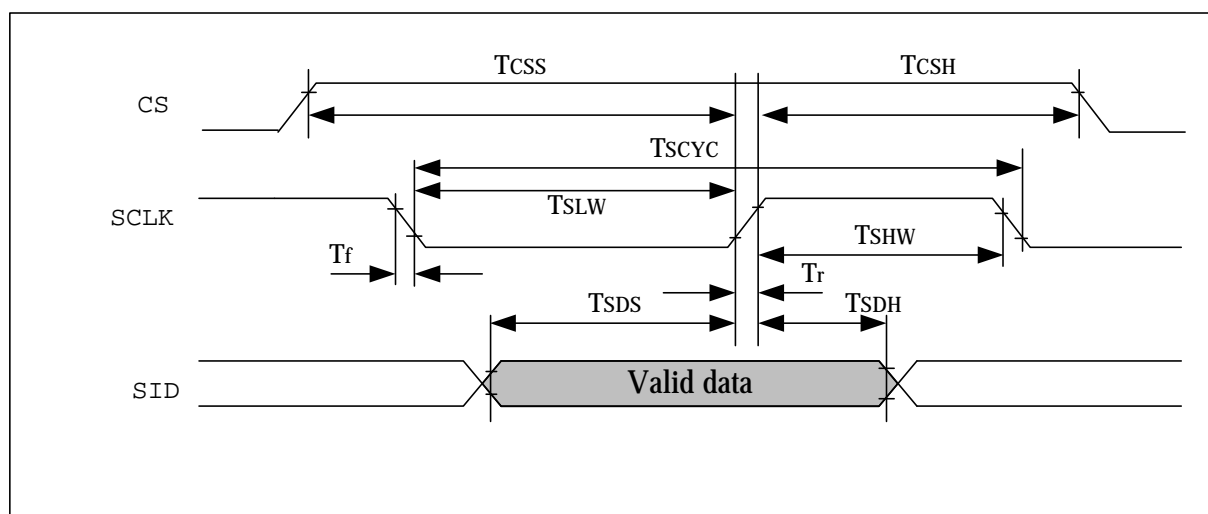

ST7920

I/O pin diagram

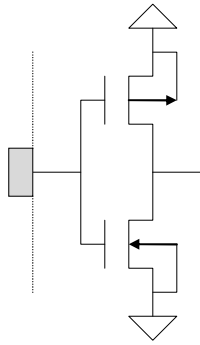

Input PAD: E (No Pull-up)

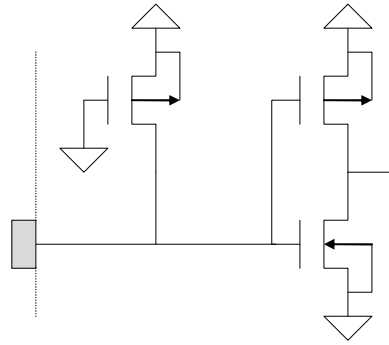

Input PAD: RS, RW (with Pull-up)

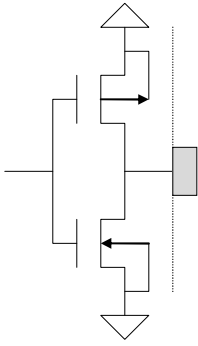

Output PAD: CL1, CL2, M, D

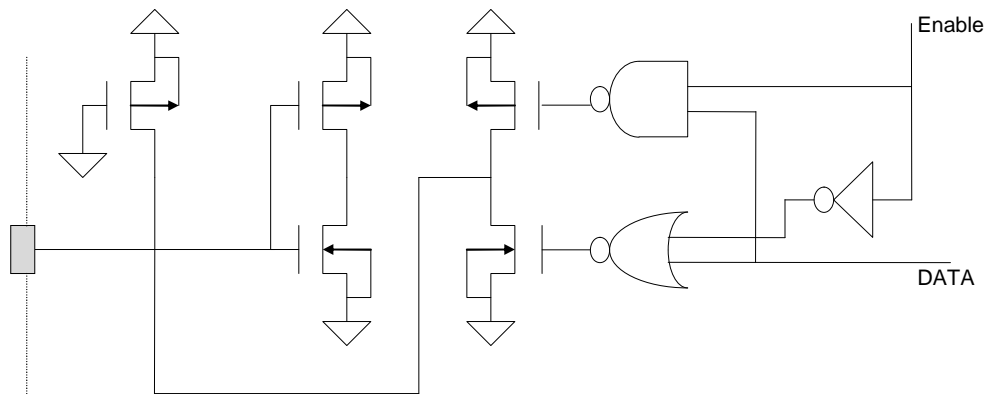

I/O PAD: DB0 – DB7

ST7920

Application circuit 1:

LCD : 32-COM x 160-SEG
LCD Voltage : VCC

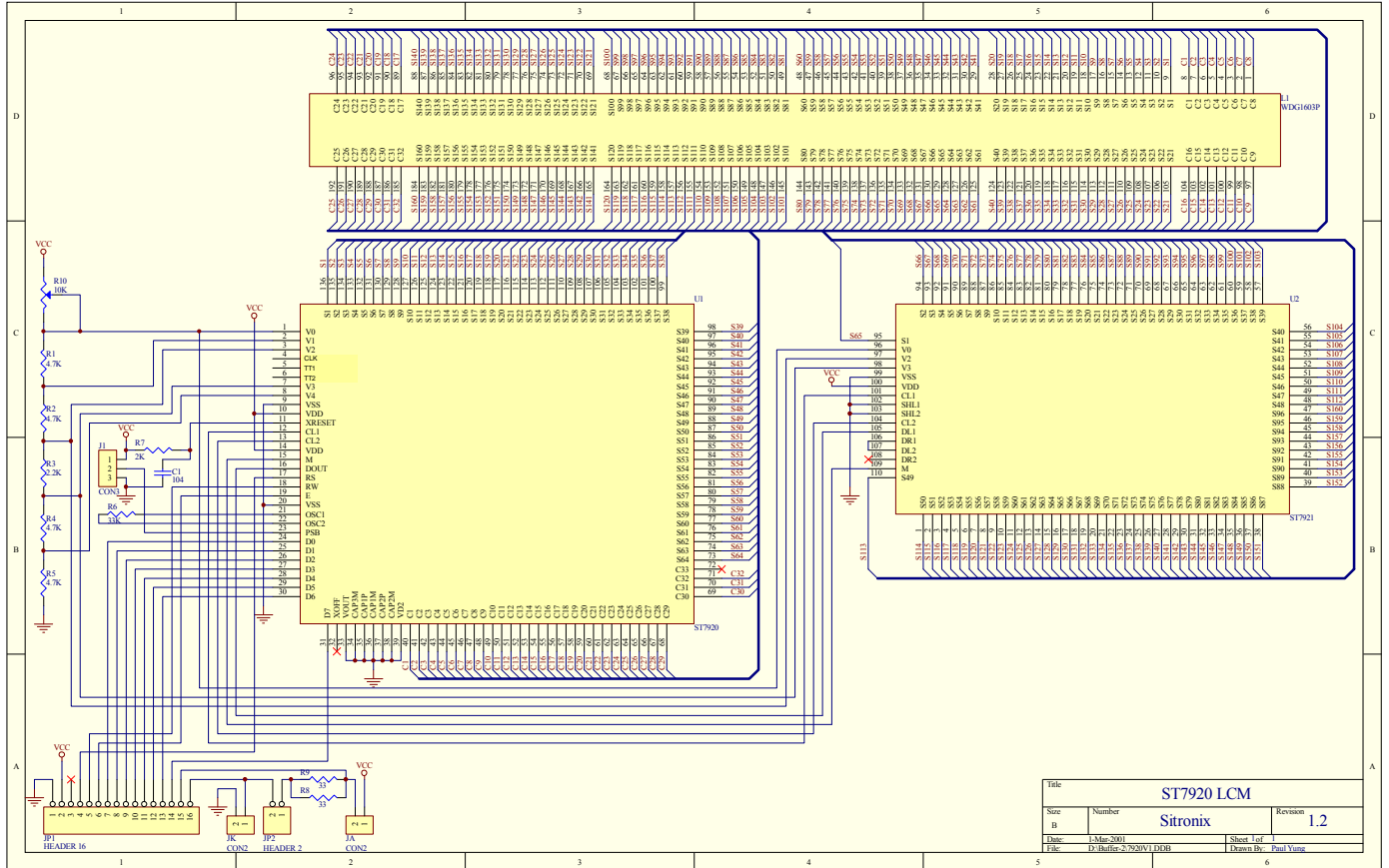

ST7920

Application circuit 2:

LCD : 32-COM x 160-SEG

LCD Voltage : VCC x 2 (Voltage doubler is used). *V_{LCD} (V_O), V_{OUT} and V_{CAP3M} should not over 7V.

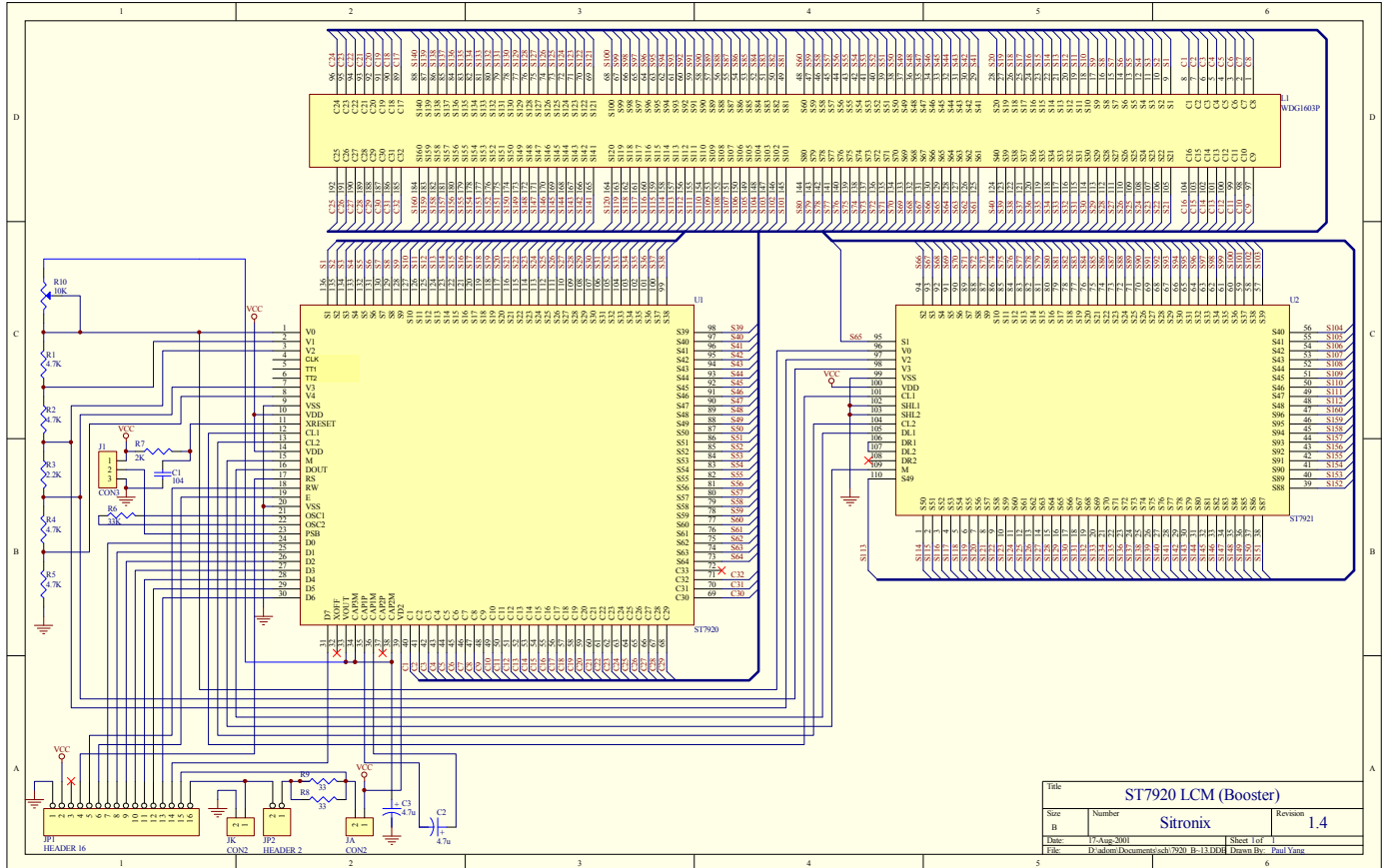

ST7920

Application circuit 3:

LCD : 2Line 16Chinese Word (32-COM x 256-SEG)

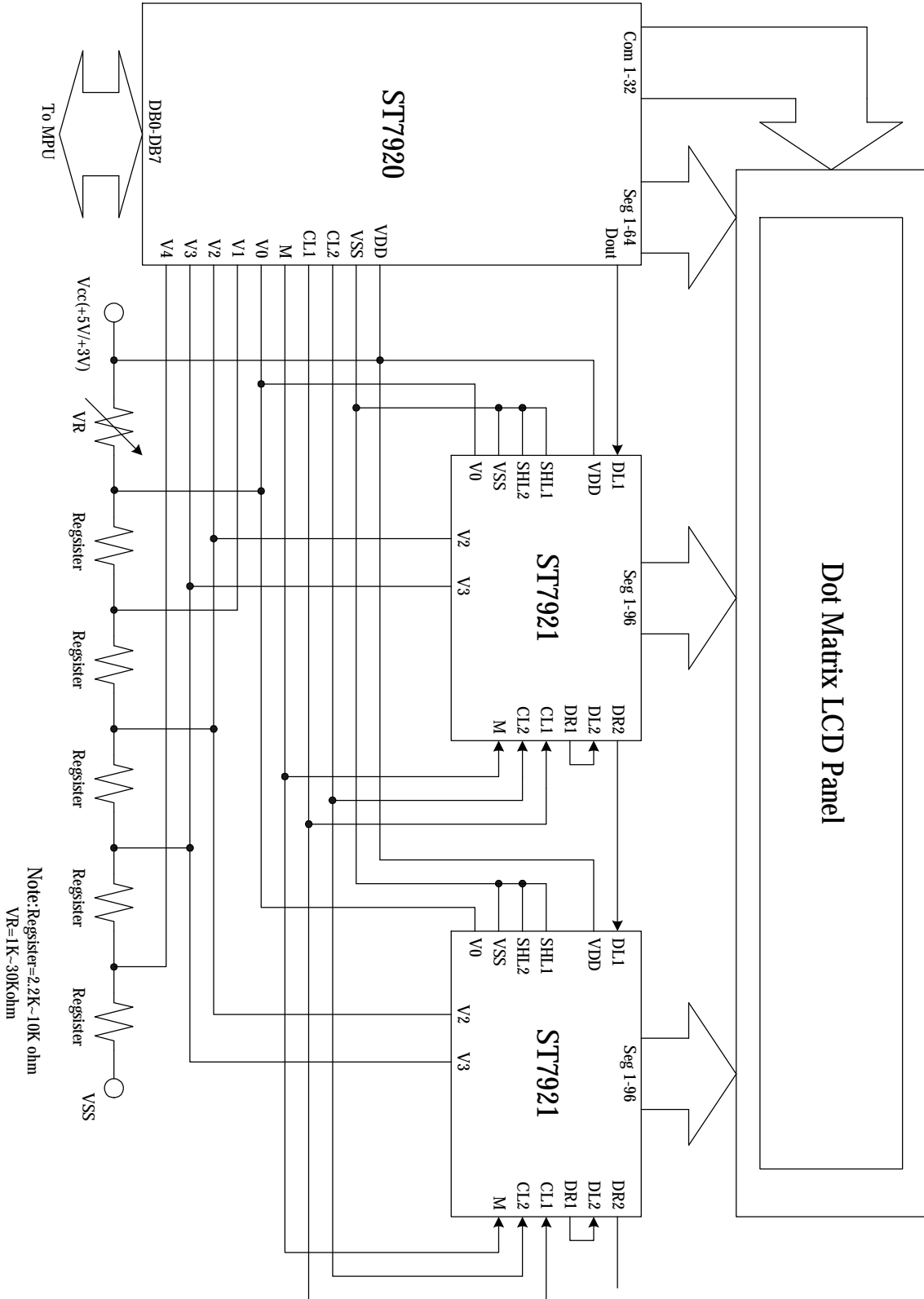

ST7920

Application circuit for testing CGROM and HCGROM:

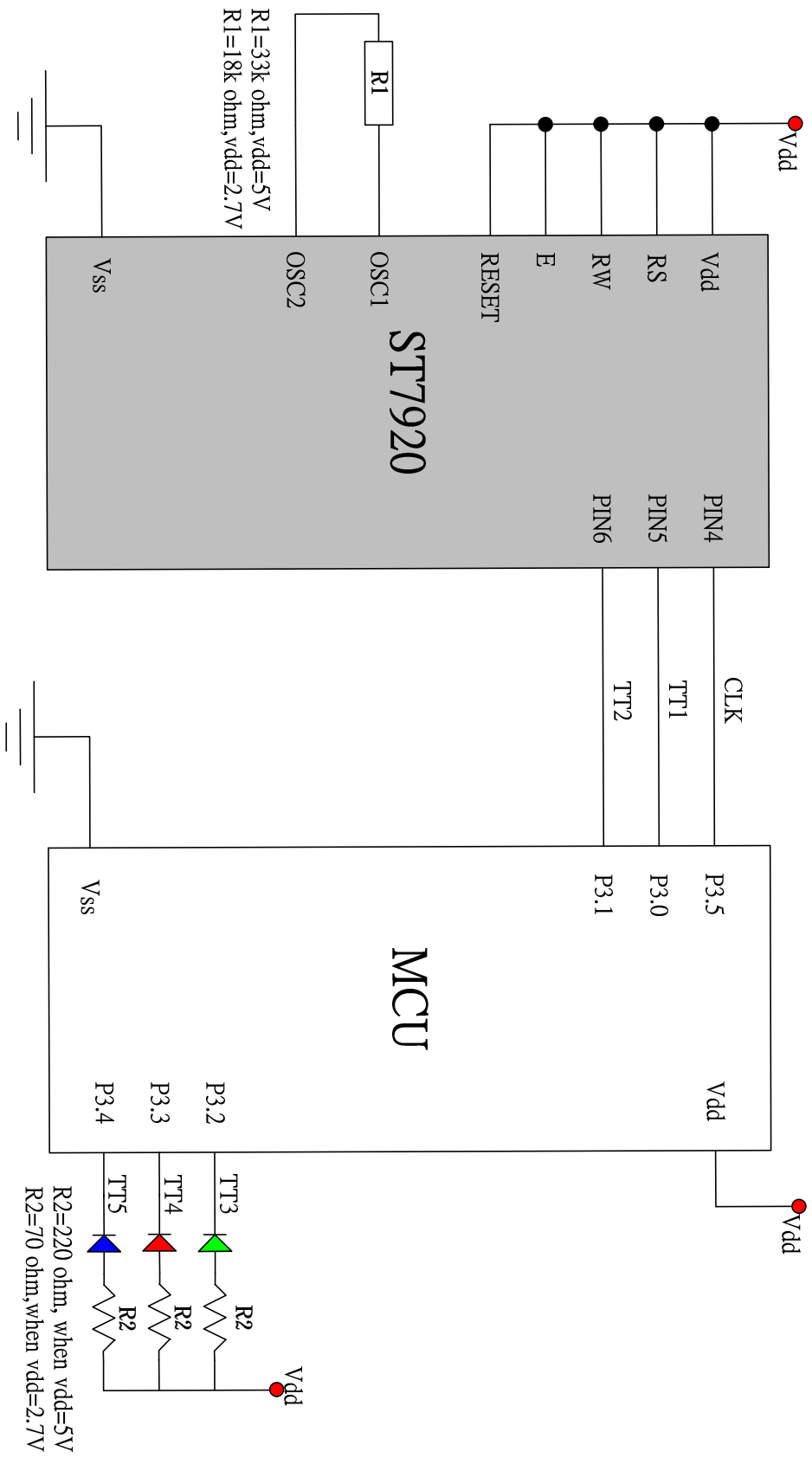

If CGROM check OK then TT3 LED turn on ,else turn off
 If HCGROM check OK then TT4 LED turn on ,else turn off
 If CGROM or HCGROM check error then TT5 LED turn on
 ,else turn off