

SPECIFICATIONS FOR LCD MODULE

CUSTOMER	
CUSTOMER PART NO.	
PART NO.	CRN-12864C
APPROVED BY	
DATE	

APPROVED BY	CHECKED BY	ORGANIZED BY

RECORD OF REVISION

Revision Date	Page	Contents
1999/11/19	-	New Release
2000/10/6	11	Add power on / off sequence
	13	Modify sampling plan
		Add White LED Back-light
2000/10/27	3, 6	

1 FEATURES

- (1) Display format : 128 · 64 dot-matrix ; 1/ 64 duty.
- (2) Construction : STN / FSTN LCD, Bezel, Zebra, Heat Seal and PCB.
- (3) Optional Edge LED or EL backlight.
- (4) Controller : KS0108B.
- (5) 5V single power input. Built-in DC/DC converter for LCD driving.
- (6) Normal / Extended temperature type.

2 NUMBERING SYSTEM

CRN-12864C _ _ _ _ -
 _ **1 2 3 4 5**

No	Code Value	Description	Remark
1	G	STN gray type LCD	LCD Type
	Y	STN yellow green type LCD	
	S	STN negative type LCD	
	F	FSTN type LCD	
2	A	Reflective type / 6:00 view	Polarizer / Viewing Angel
	B	Reflective type / 12:00 view	
	I	Transflective type / 6:00 view	
	J	Transflective type / 12:00 view	
	T	Negative type / 6:00 view	
	U	Negative type / 12:00 view	
3	None	Without backlight	Backlight type
	Q	5V Edge type LED	
	E	EL	
4	None	Without backlight	Backlight color
	Y	Yellow-green (LED)	
	B	Blue (EL)	
	W	White (EL, LED)	
5	None	Normal temperature type	LCM temperature type
	H	Extended temperature type	

2 MECHANICAL DATA

Parameter	Stand Value	Unit
Dot size	0.40(W) · 0.56(H)	mm
Dot pitch	0.44(W) · 0.60(H)	mm
Viewing area	62.0(W) · 44.0(H)	mm
Module size	78.0(W) · 70.0(H) · 10.5 max (T)	mm
Module size (w/ LED back-light)	78.0(W) · 70.0(H) · 13.0 max (T)	mm

3 ABSOLUTE MAXIMUM RATINGS

Parameter		Symbol	Min	Max	Unit
Logic Circuit Supply Voltage		VDD-VSS	0	7.0	V
LCD Driving Voltage		VDD-VO	0	20	V
Input Voltage		VI	VSS	VDD	V
Normal temp. type	Operating Temp.	TOP	0	50	°C
	Storage Temp.	TSTG	-20	70	°C
Extended temp. type	Operating Temp.	TOP	-20	70	°C
	Storage Temp.	TSTG	-30	80	°C

4 ELECTRO-OPTICAL CHARACTERISTICS

Parameter	Symbol	Condition	Min	Typ	Max	Unit	Note
----- Electronic Characteristics -----							
Logic Circuit Supply Voltage	VDD-VSS	--	4.5	5.0	5.5	V	
LCD Driving Voltage	VDD-VO	-20 °C	8.4	9.2	10.0	V	0 ~ 50 °C for Normal Temp. type -20 ~ 70 °C for Extended Temp. type
		0 °C	8.4	9.2	10.0		
		25 °C	8.4	9.2	10.0		
		50 °C	8.4	9.2	10.0		
		70 °C	8.4	9.2	10.0		
Input Voltage	VIH	--	0.7 VDD	--	VDD	V	
	VIL	--	VSS	--	0.3 VDD	V	
Logic Supply Current	IDD	VDD = 5V	--	3	4	mA	
----- Optical Characteristics -----							
Contrast	CR	STN type	--	4.2	--		Note 1
		FSTN type		7			
Rise Time	tr	25 °C	--	140	--	ms	Note 2
Fall Time	tf	25 °C	--	240	--	ms	
Viewing Angle Range	? f	25 °C & CR=2	--	40	--	Deg.	Note 3
	? b		--	35	--		
	? l		--	35	--		
	? r		--	35	--		
Frame Frequency	fF	25 °C	--	70	--	Hz	
----- Yellow-green LED Back-light Characteristics -----							
Forward Voltage	VF	--	--	4.05	4.3	V	Supply Voltage between A&K
Forward Current	IF	VF=4.05V	--	100	--	mA	
Bare LED Luminous intensity		VF=4.05V	--	20	--	cd/m ²	
LCM Luminous intensity		VF=4.05V	--	7	--	cd/m ²	



----- White Edge LED Back-light Characteristics -----							
Forward Voltage	VF	--	7.2	7.6	8.0	V	Supply Voltage between A&K
Forward Current	IF	VF=7.6V	--	100	--	mA	
Bare LED Luminous intensity	VF=7.6V	--	30	--	cd/m ²		
LCM Luminous intensity	VF=7.6V	--	10	--	cd/m ²		

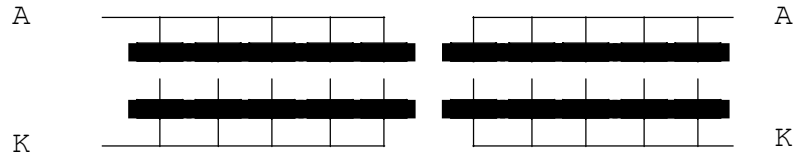

Parameter	Min	Typ	Max	Unit	Note
----- EL Back-light Characteristics -----					
Driving Voltage	--	110	--	Vrms	
Frequency	--	400	--	Hz	
Bare EL Luminous intensity	--	50	--	cd/m ²	
LCM Luminous intensity	--	15	--	cd/m ²	

(NOTE 1) Contrast ratio :

$$CR = (\text{Brightness in OFF state}) / (\text{Brightness in ON state})$$

(NOTE 2) Response time :

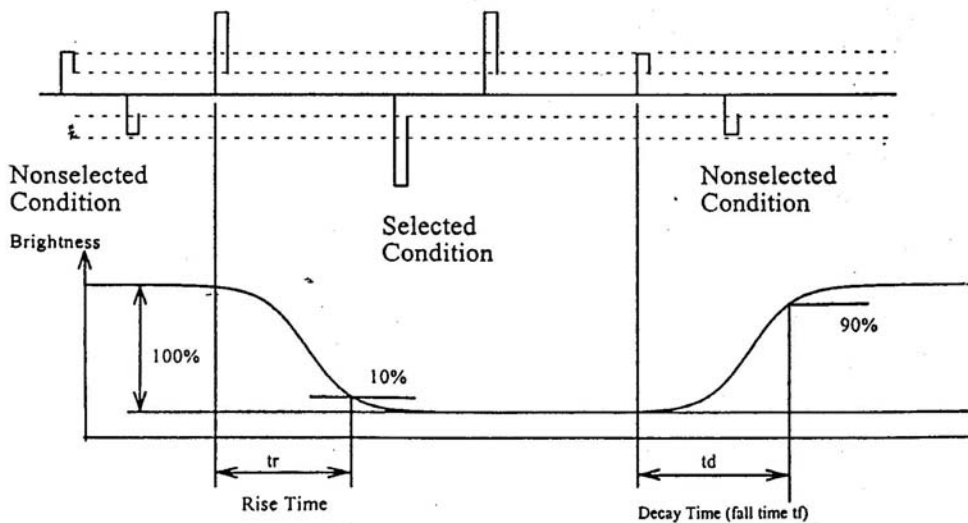

(NOTE 3) Viewing angle

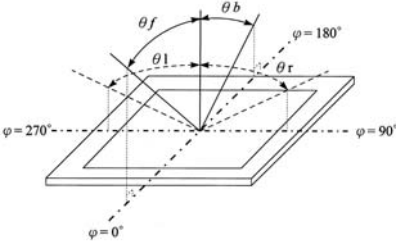

5 BLOCK DIAGRAM & POWER SUPPLY

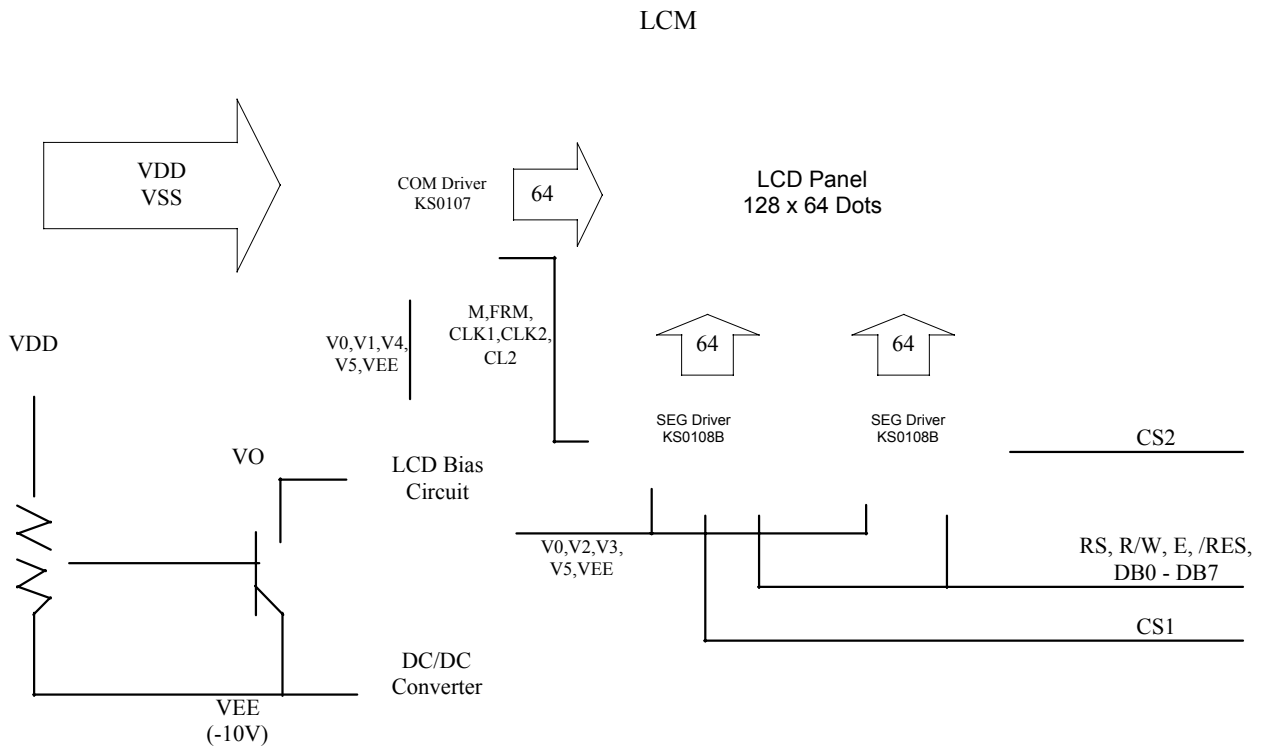

Using LED Back-light



Using EL Back-light

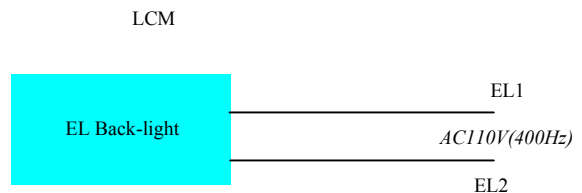

6 PIN CONNECTIONS

No.	Symbol	Function
1	/CSA	Chip Selection For ICA
2	/CSB	Chip Selection For ICB
3	VSS	Ground (0V)
4	VDD	Supply Voltage for Logic (+5V)
5	VO	Contrast adjustment
6	D/I	Data or Instruction
7	R/W	Read or Write
8	E	Enable signal
9-16	DB0-DB7	Data Bus Line
17	/RST	Reset
18	VEE	Negative Power Supply Output (-5V)
19	LEDA	LED Back-light Power Supply + (5V)
20	LEDK	LED Back-light Power Supply - (5V)

7 TIMING CHARACTERISTICS

Item	Symbol	Min	Typ	Max	Unit
Enable Cycle Time	tCYCLE	1000	-	-	ns
Enable Pulse Width	High Level	PWEH	450	-	ns
	Low Level	PWEL	450	-	ns
Enable Rise & Fall Time	tER,tEF	-	-	25	ns
Address Set-Up Time	tAs	140	-	-	ns
Address Hold Time	tAH	10	-	-	ns
Data Set-Up Time	tDSW	200	-	-	ns
Data Delay Time	tDDR	--	-	320	ns
Data Hold Time(Write)	tDHW	10	-	-	ns
Data Hold Time(Read)	tDHW	20	-	-	ns

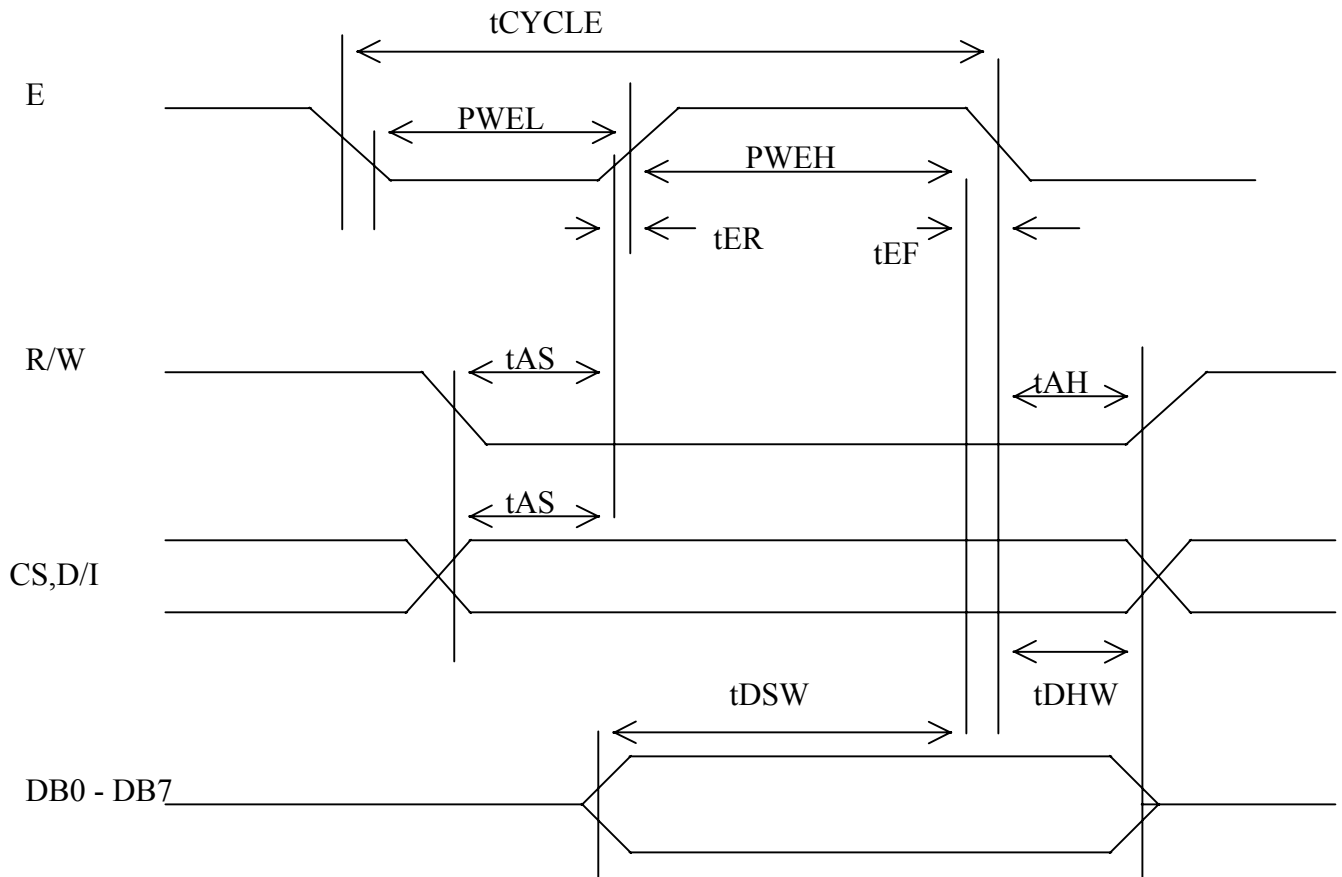

Write Timing Chart

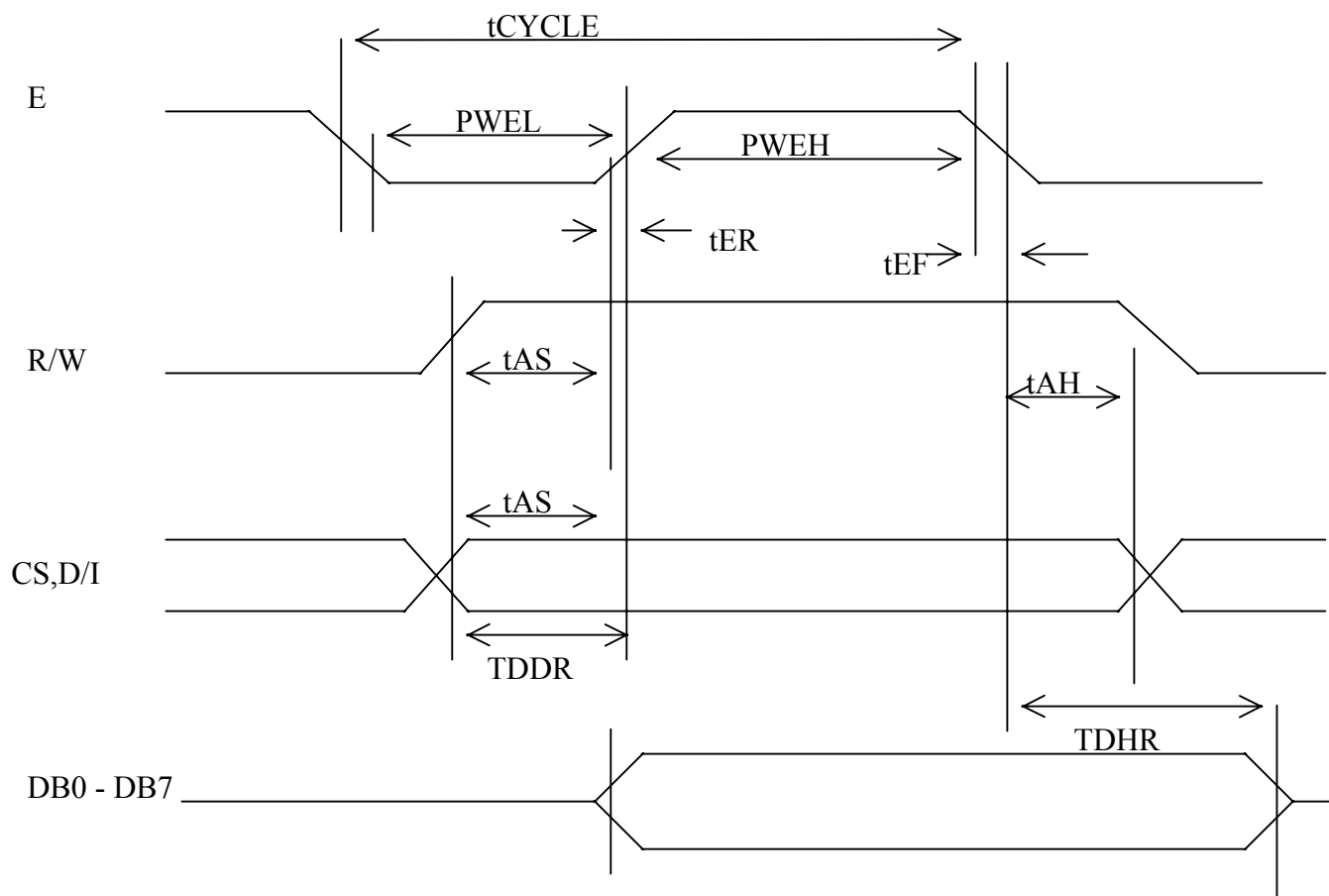

Read Timing Chart

7.1 Power ON/OFF Sequence

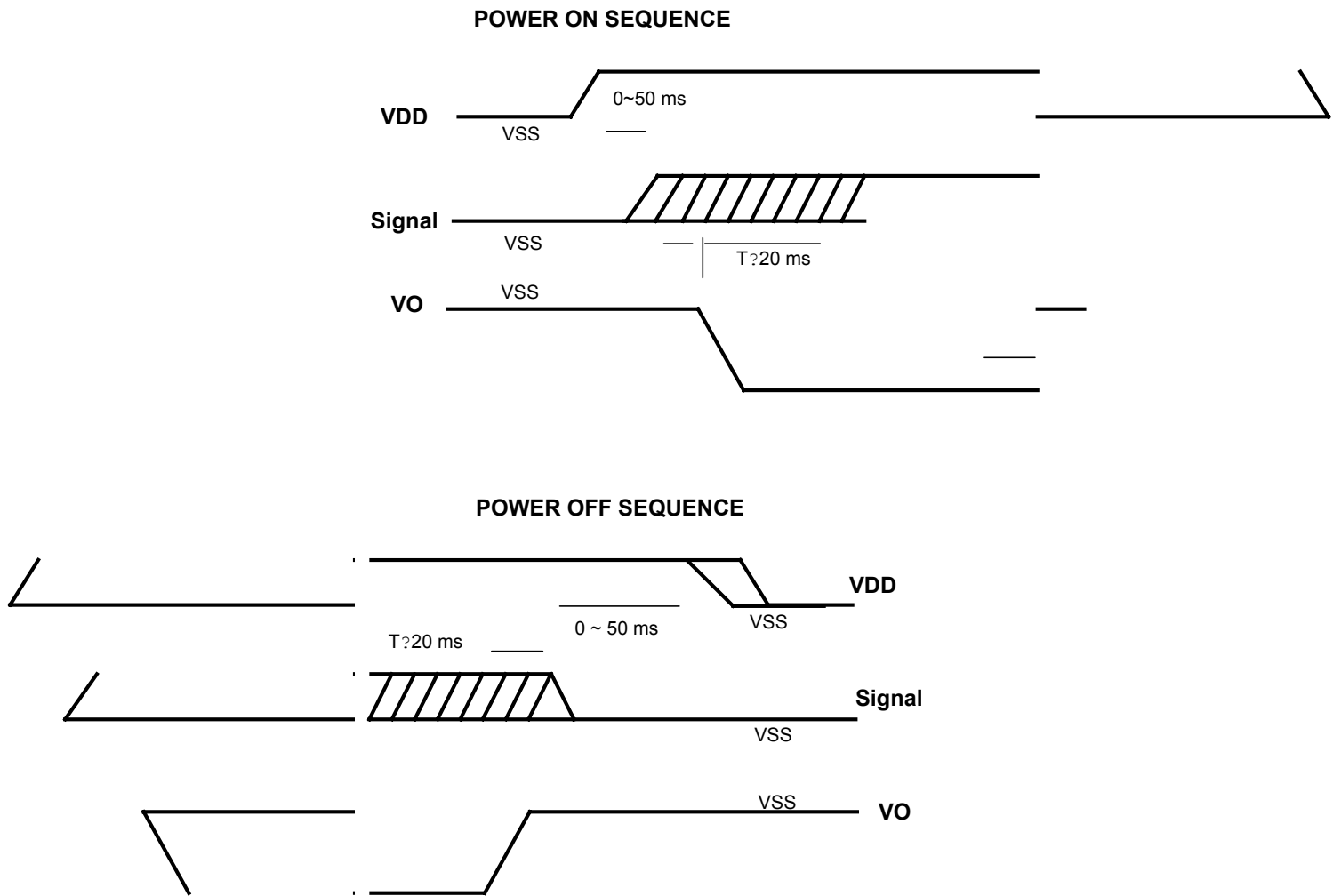

8 INSTRUNTION SET

The display control instructions control the internal state of the KS0108B. Instruction is received from MPU to KS0108B for the display control. The following table shows various instructions.

Instruction	RS	R/W	DB7	DB6	DB5	DB4	DB3	DB2	DB1	DB0	Function	
Display ON/OFF	L	L	L	L	H	H	H	H	H	L/H	Controls the display on or off. Internal status and display RAM data is not affected. L:OFF, H:ON	
Set Address (Y address)	L	L	L	H	Y address (0~63)						Sets the Y address in the Y address counter.	
Set Page (X address)	L	L	H	L	H	H	H	Page (0~7)			Sets the X address at the X address register.	
Display Start Line (Z address)	L	L	H	H	Display start line (0~63)						Indicates the display data RAM displayed at the top of the screen.	
Status Read	L	H	B U S Y	L	O N / O F F	R E S E T	L	L	L	L	Read status. BUSY L: Ready H: In operation ON/OFF L: Display ON H: Display OFF RESET L: Normal H: Reset	
Write Display Data	H	L	Write Data									Writes data (DB0:7) into display data RAM. After writing instruction, Y address is increased by 1 automatically.
Read Display Data	H	H	Read Data									Reads data (DB0:7) from display data RAM to the data bus.

9 QUALITY AND RELIABILITY

9.1 TEST CONDITIONS

Tests should be conducted under the following conditions :

Ambient temperature : $25 \pm 5^{\circ}\text{C}$

Humidity : $60 \pm 25\% \text{ RH}$.

9.2 SAMPLING PLAN

Sampling method shall be in accordance with MIL-STD-105E , level II, normal single sampling plan .

9.3 ACCEPTABLE QUALITY LEVEL

A major defect is defined as one that could cause failure to or materially reduce the usability of the unit for its intended purpose. A minor defect is one that does not materially reduce the usability of the unit for its intended purpose or is an infringement from established standards and has no significant bearing on its effective use or operation.

9.4 APPEARANCE

An appearance test should be conducted by human sight at approximately 30 cm distance from the LCD module under flourescent light. The inspection area of LCD panel shall be within the range of following limits.

9.5 INSPECTION QUALITY CRITERIA

Item	Description of defects			Class of Defects	Acceptable level (%)	
Function	Short circuit or Pattern cut			Major	0.65	
Dimension	Deviation from drawings			Major	1.5	
Black spots	Ave . dia . D	area A	area B	Minor	2.5	
	D=0.2	Disregard				
	0.2<D=0.3	3	4			
	0.3<D=0.4	2	3			
	0.4<D	0	1			
Black lines	Width W, Length L		A	B	Minor	2.5
	W=0.03		disregard			
	0.03<W=0.05		3	4		
	0.05<W=0.07 , L=3.0		1	1		
	See line criteria					
Bubbles in polarizer	Average diameter D 0.2 < D < 0.5 mm for N = 4 , D > 0.5 for N = 1			Minor	2.5	
Color uniformity	Rainbow color or newton ring.			Minor	2.5	
Glass Scratches	Obvious visible damage.			Minor	2.5	
Contrast ratio	See note 1			Minor	2.5	
Response time	See note 2			Minor	2.5	
Viewing angle	See note 3			Minor	2.5	

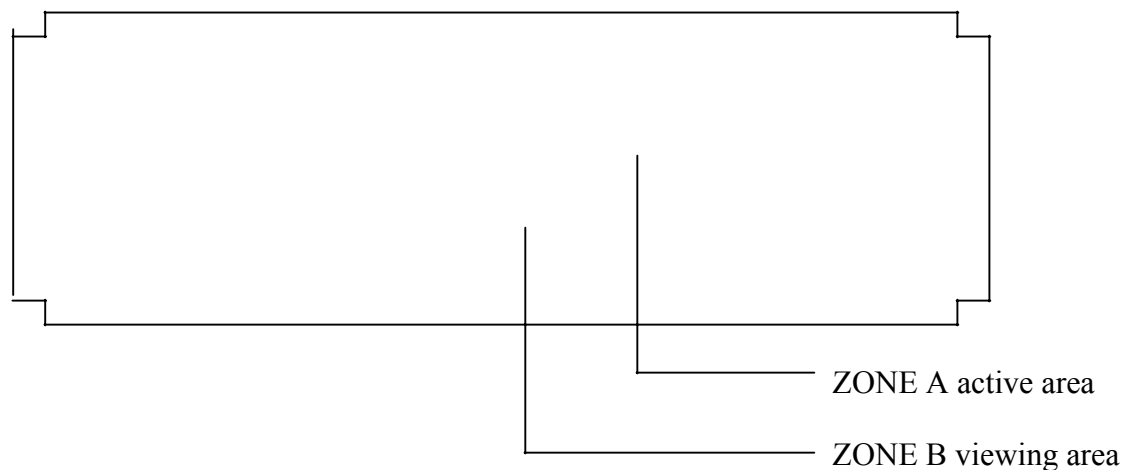

9.6 RELIABILITY

Test Item	Test Conditions		Note
	Normal Temp. type	Extended Temp. type	
High Temperature Operation	50±3°C , t=96 hrs	70±3°C , t=96 hrs	
Low Temperature Operation	0±3°C , t=96 hrs	-20±3°C , t=96 hrs	
High Temperature Storage	70±3°C , t=96 hrs	80±3°C , t=96 hrs	1,2
Low Temperature Storage	-20±3°C , t=96 hrs	-30±3°C , t=96 hrs	1,2
Temperature Cycle	-20°C ~ 25°C ~ 70°C 30 m in. 5 min. 30 min. (1 cycle) Total 5 cycle	-30°C ~ 25°C ~ 80°C 30 min. 5 min. 30 min. (1 cycle) Total 5 cycle	1,2
Humidity Test	40 °C, Humidity 90%, 96 hrs		1,2
Vibration Test (Packing)	Sweep frequency : 10 ~ 55 ~ 10 Hz/1min Amplitude : 0.75mm Test direction : X.Y.Z/3 axis Duration : 30min/each axis		2

Note 1 : Condensation of water is not permitted on the module.

Note 2 : The module should be inspected after 1 hour storage in normal conditions (15-35°C , 45-65%RH).

Definitions of life end point :

- ! Current drain should be smaller than the specific value.
- ! Function of the module should be maintained.
- ! Appearance and display quality should not have degraded noticeably.
- ! Contrast ratio should be greater than 50% of the initial value.

10 HANDLING PRECAUTIONS

- (1) A LCD module is a fragile item and should not be subjected to strong mechanical shocks.
- (2) Avoid applying pressure to the module surface. This will distort the glass and cause a change in color.
- (3) Under no circumstances should the position of the bezel tabs or their shape be modified.
- (4) Do not modify the display PCB in either shape or positioning of components.
- (5) Do not modify or move location of the zebra or heat seal connectors.
- (6) The device should only be soldered to during interfacing. Modification to other areas of the board should not be carried out.
- (7) In the event of LCD breakage and resultant leakage of fluid do not inhale, ingest or make contact with the skin. If contact is made rinse immediately.
- (8) When cleaning the module use a soft damp cloth with a mild solvent, such as Isopropyl or Ethyl alcohol. The use of water, ketone or aromatic is not permitted.
- (9) Prior to initial power up input signals should not be applied.
- (10) Protect the module against static electricity and observe appropriate anti-static precautions.

11 OUTLINE DIMENSION

