

PROTON

PICmicrotm

Development Board

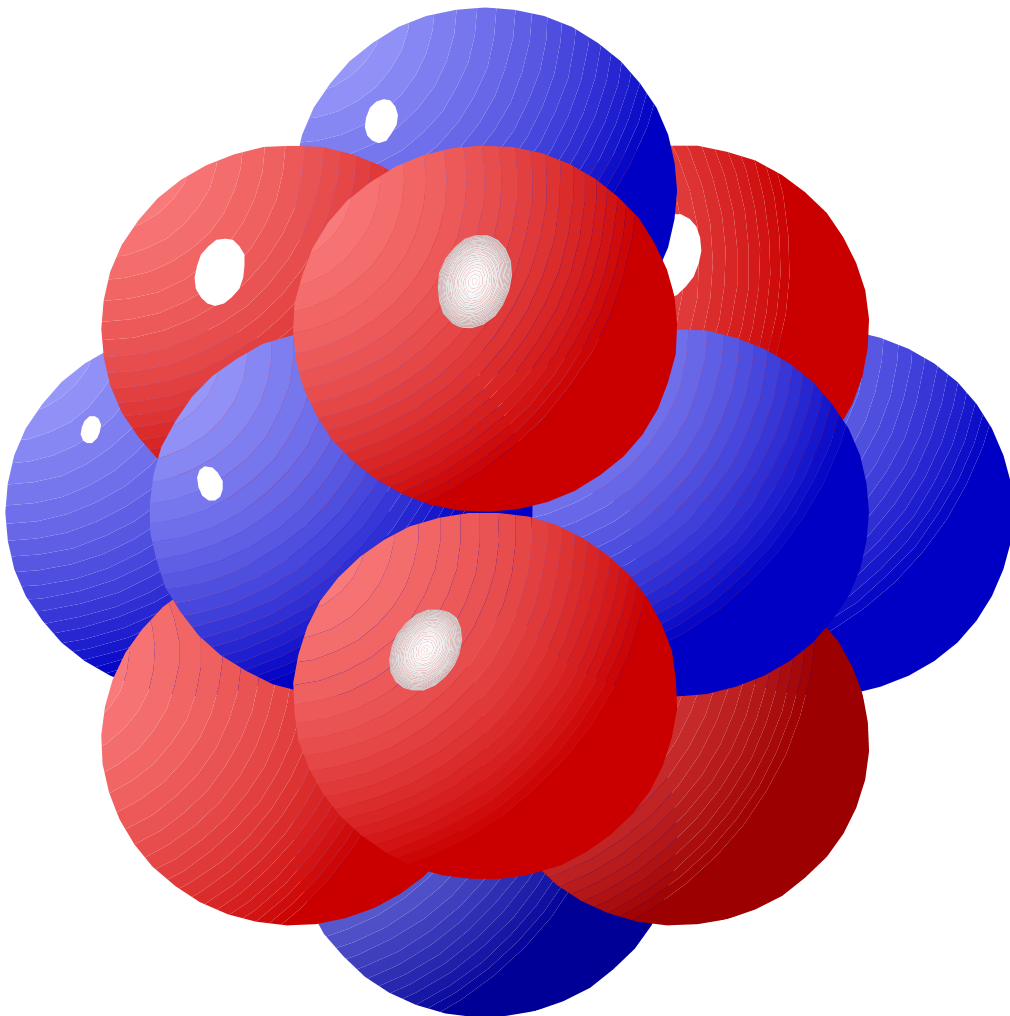

Crownhill Associates
smart electronic solutions

PROTON Development Board MKII

Disclaimer

In order to comply with EMC directive 89/336/EEC, this product should not be used outside of a classroom or laboratory environment.

Any software supplied with this product is provided in an “as is” condition. No warranties, whether express, implied or statutory, including, but not limited to, implied warranties of merchantability and fitness for a particular purpose apply to this software. The company shall not, in any circumstances, be liable for special, incidental or consequential damages, for any reason whatsoever.

This product should not be used as a critical component in life support systems. Crownhill does not recommend the use of any of its products in life support applications where the failure or malfunction of the product can reasonably be expected to cause failure in the life support system or to significantly affect its safety or effectiveness.

In producing this document and the associated hardware we have spent a great deal of time to ensure the accuracy of the information presented. We constantly strive to improve the quality of our products and documentation. Crownhill operates a quality system conforming to the requirements of BS EN ISO9001 : 2000. Crownhill reserves the right to change the functionality and specifications of its products from time to time without prior notice.

If you should find any errors or omission in these documents or hardware, please contact us, we appreciate your assistance in improving our products and services.

Crownhill reserves the right to make changes to the products contained in this publication in order to improve design, performance or reliability. Crownhill assumes no responsibility for the use of any circuits described herein, conveys no license under any patent or other right, and makes no representation that the circuits are free of patent infringement. Charts and schedules contained herein reflect representative operating parameters, and may vary depending upon a user's specific application. While the information in this publication has been carefully checked, Crownhill shall not be liable for any damages arising as a result of any error or omission.

PICmicro[™] is a trade name of Microchip Technologies Inc.

PROTON[™] is a trade name of Crownhill Associates Ltd.

EPIC[™] is a trade name of microEngineering Labs Inc.

This document was published by Crownhill associates limited, Cambridge England, 2003

PROTON Development Board MKII

Table of Contents.

| | |
|---|----|
| Introduction | 3 |
| Adding the Graphic LCD. | 4 |
| Graphic LCD test program. | 5 |
| Circuit Diagrams. | 7 |
| Power Supply. | 7 |
| In-Circuit-Programming Header..... | 8 |
| RS232 Transceiver. | 9 |
| Alphanumeric LCD..... | 10 |
| Graphic LCD. | 11 |
| 16-Button Keypad. | 12 |
| 8 x LEDs..... | 13 |
| 100K Potentiometer. | 14 |
| PICmicro tm Microcontroller. | 15 |
| I2C Eeprom. | 16 |
| SPI Eeprom..... | 17 |
| Infra-red Transmitters and Receiver..... | 18 |
| 40 pin Microcontroller link socket. | 19 |
| Development Breadboard area. | 20 |
| The PROTON Board and the PROTON Compilers | 21 |
| Using the built-in PIC16F87x bootloader | 22 |

PROTON Development Board MKII

Introduction

The Crownhill PROTON PICmicro™ Development Board is a must for developers of PICmicro™ applications. Whether just beginning, or a seasoned veteran, the PROTON board offers a rapid solution to be realised.

On board peripherals include, 16-button keypad, LCD (graphic or alphanumeric), LEDs (4x red, 4 x green), serial eeproms (I²C and SPI), RS232 serial port, Infra-red transmitters and receiver, and a choice of crystal frequencies.

Not to mention the PICmicro's own facilities, such as 8K program space, 368 bytes of user RAM, 256 bytes of user eeprom, Eight channel Analogue to Digital converter, USART, MSSP module offering PWM, I²C, SPI, and parallel configurations.

The choice of options is extensive enough to make the PROTON board a single solution for a multitude of challenges.

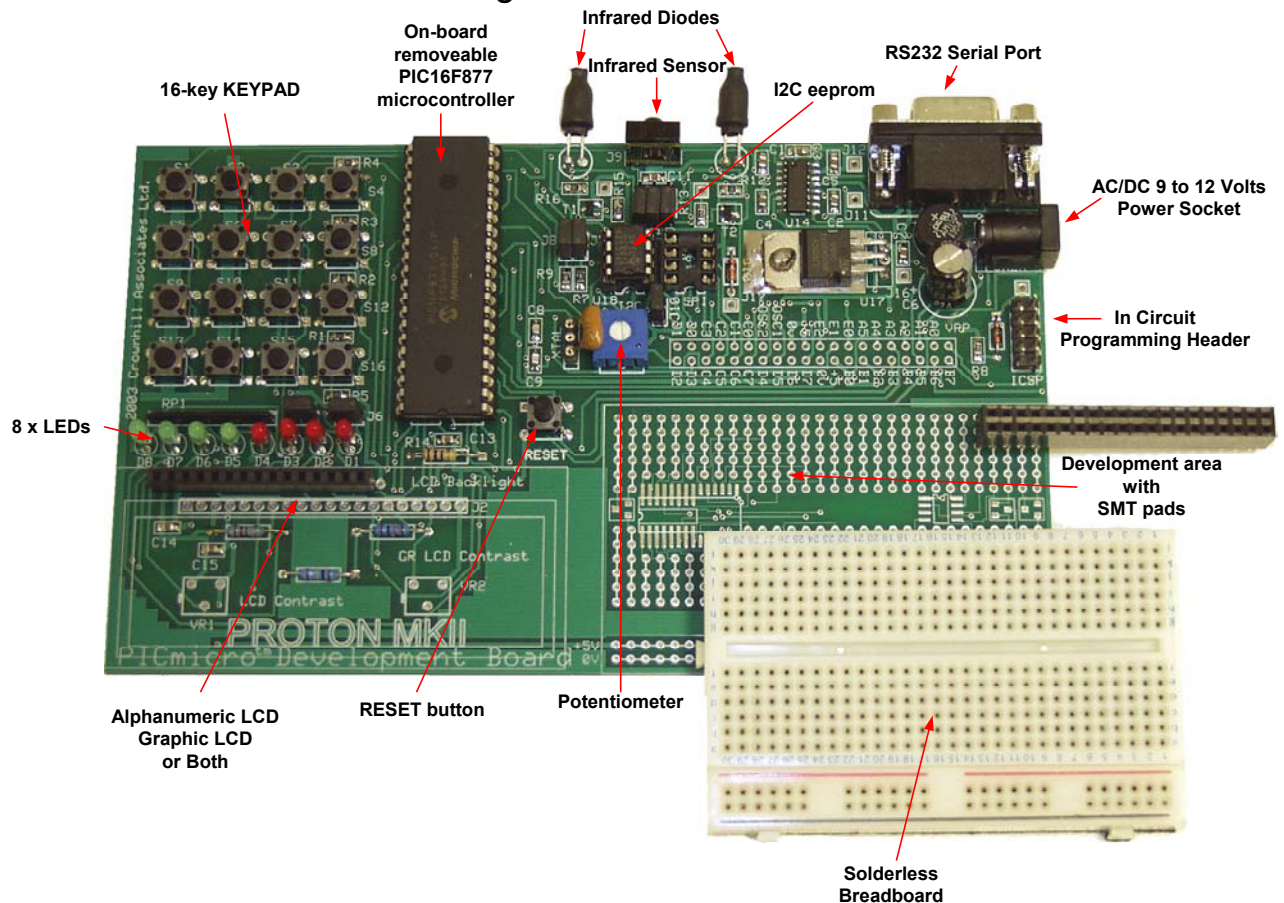

PROTON Development Board MKII

Adding the Graphic LCD.

If you've purchased the graphic LCD as a separate kit, you will have received 2 items.

- 20 pin socket.
- AMPIRE 12864 graphic LCD.

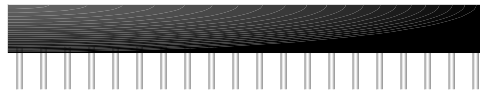

20 pin LCD Socket

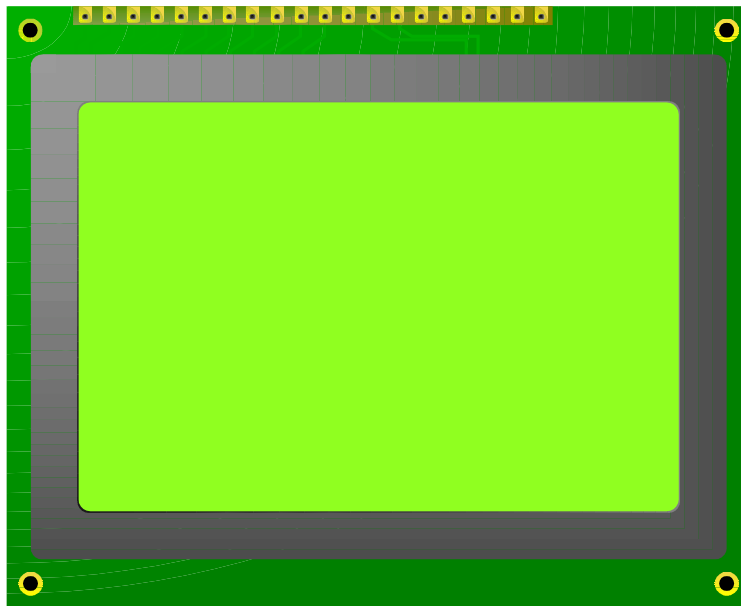

AMPIRE 12864 Graphic LCD

If either of these items are missing or incorrect, please contact Crownhill Associates for a replacement or assistance.

The diagram below illustrates where each device should be located.

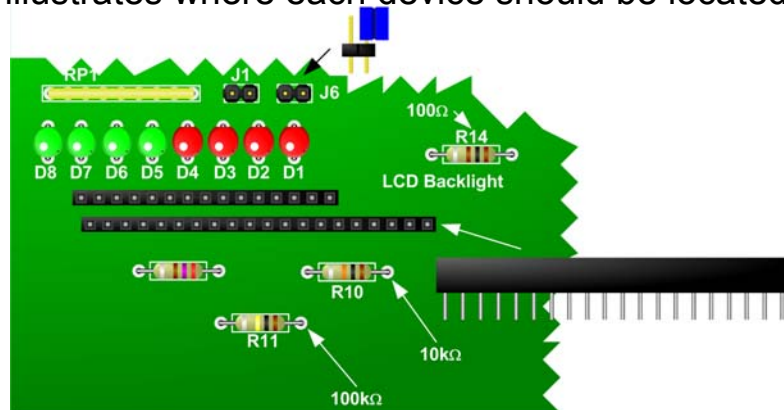

Once the 20-pin socket has been soldered into place and checked for dry joints, and solder splashes, the LCD itself can be inserted into the socket, and the power connected.

PROTON Development Board MKII

Graphic LCD test program.

The graphic LCD itself will not do much of anything, until it has a program controlling it. So in order to test the graphic LCD, type in the program below.

Note: this program, as with all the programs in this manual, are written for the Crownhill PROTON+ compiler Version 2.0 onwards.

Ensure that a 4MHz crystal or resonator is fitted into the XTAL socket, as the program is written for this speed oscillator.

```
INCLUDE "PROTON_G4.INT"           ' Use a 4MHz XTAL

DIM XPOS AS BYTE
DIM YPOS AS BYTE

CLS
PRINT AT 0, 2, "GRAPHIC LCD TEST" ' Display text
AGAIN:
FOR XPOS = 0 TO 63                ' Create a loop of 64
YPOS = SIN XPOS                   ' Extract SIN of YPOS
PLOT XPOS, YPOS                   ' Plot an ARC
DELAYMS 10
NEXT                               ' Close the loop
FOR XPOS = 0 TO 63                ' Create a loop of 64
YPOS = SIN XPOS                   ' Extract SIN of YPOS
UNPLOT XPOS, YPOS                 ' Remove the ARC
DELAYMS 10
NEXT                               ' Close the loop
GOTO AGAIN

INCLUDE "FONT.INC"                ' Add the LCD's Font
```

PROTON Development Board MKII

Infrared test program.

As with the graphic LCD, the infrared components don't do a great deal until a program controls them, or takes control from them.

So we'll test the infrared receiver module, by creating a program to decode signals sent by a Sony remote control handset. Type in the following program:

```
INCLUDE "PROTON_4.INC"
DIM HEADER AS WORD      ' Header pulse length
DIM PACKET AS HEADER    ' 12-bit IR information
DIM IR_BUT AS BYTE      ' The BUTTON code
DIM IR_DEV AS BYTE      ' The DEVICE code
DIM SONY_LP AS BYTE     ' Loop variable
SYMBOL IR_SENSOR = PORTC.0 ' Assign the IR Sensor
CLS
Again:
WHILE 1 = 1
GOSUB IRIN                ' Receive an IR signal
IF IR_DEV = 255 THEN Again ' Check if header was valid
PRINT AT 1, 1, DEC IR_DEV, " ", DEC IR_BUT, " "
DELAYMS 100              ' Delay for 100ms
WEND                      ' Do it forever
IRIN:                    ' Receive a signal from a Sony remote control
SET IR_DEV
SET IR_BUT
HEADER = PULSIN IR_SENSOR,Low ' Measure the header
IF HEADER < 200 OR HEADER > 270 THEN RETURN
CLEAR SONY_LP
REPEAT                    ' Implement a loop for the 12 bits
CLEAR PACKET.11          ' Default to a clear bit (zero-bit)
IF PULSIN IR_SENSOR,Low >= 90 THEN SET PACKET.11
PACKET = PACKET >> 1     ' Shift the bits right 1 place
INC SONY_LP              ' Increment the loop counter
UNTIL SONY_LP = 11       ' Close the loop after 12 bits
' Split the 7-bit BUTTON, and the 5-bit DEVICE code
IR_BUT = PACKET & %01111111 ' Mask the BUTTON bits
PACKET = PACKET << 1     ' Move bit 7 into bit 8
IR_DEV = Packet.Highbyte & %00011111
RETURN
```

Don't forget to connect jumper J3, to engage the IR sensor to PORTC.0. See circuit section for more details.

PROTON Development Board MKII

Circuit Diagrams.

The circuit of the PROTON development board is split into several sections, each attached to the on-board PICmicro™ microcontroller in some way.

- Power Supply.
- In-Circuit-Programming.
- RS232 Transceiver.
- Graphic LCD (optional).
- Alphanumeric LCD.
- 16 button Keypad.
- 8 LEDs.
- 100kΩ Potentiometer.
- PIC16F877 PICmicro Microcontroller.
- SPI eeprom (optional).
- I²C eeprom.
- Infrared Transmitters / Receiver (optional).
- 40 Pin Microcontroller Link socket.
- Solderless breadboard.

Power Supply.

The power supply is a conventional rectifier – regulator type, supplying 5 Volts to the board with approx 500mA to 750mA of current. Using the bridge rectifier allows both an external AC or DC supply of between 6 and 9 Volts to be used. Any higher than 9 Volts will cause the 7805 regulator to become unreliably hot. The circuit of the Power supply is shown below: -

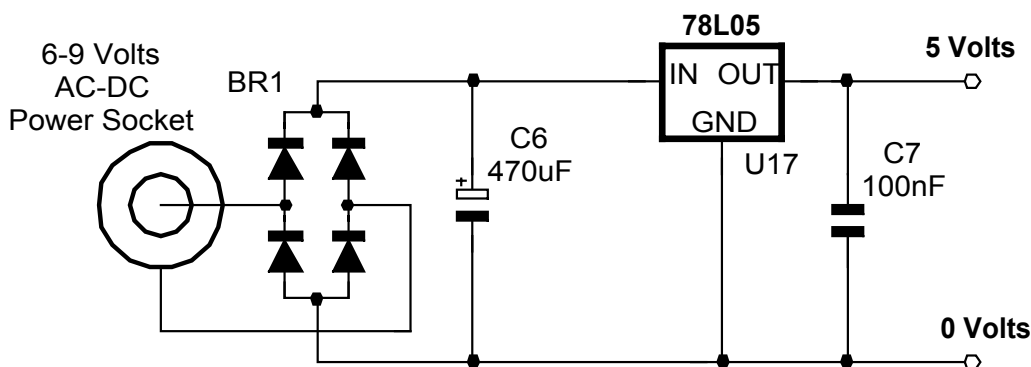

Power Supply circuit.

PROTON Development Board MKII

In-Circuit-Programming Header.

The In-Circuit-Programming section, allows the on-board 16F877 PICmicro™, to be programmed in circuit. A suitable programmer must be used, such as the microEngineering Labs EPIC™ programmer. The circuit for this section is shown below: -

The PICmicro™ programmer must be fitted to the 10-pin header, preferably using a short ribbon cable and suitable header sockets. The programming pins are connected to the relevant programming pins of the PICmicro. The inclusion of the push switch allows the PICmicro™ to be RESET while developing software. D9 stops any high voltage leaking into the 5 Volt supply when the microcontroller is being programmed, as most devices require at least 12 Volts on their VPP pins. Resistor R9 stops the 5 Volt line from becoming short circuit when the RESET switch is operated.

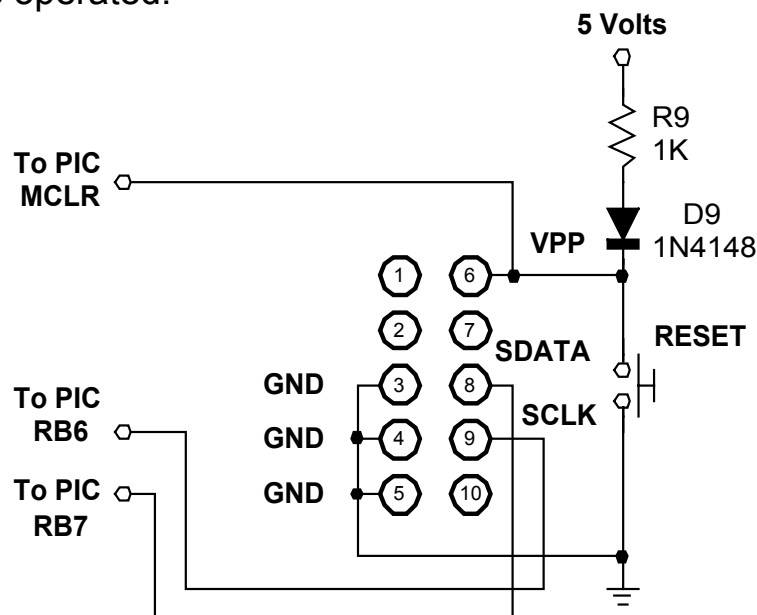

In-Circuit-Programming section.

PROTON Development Board MKII

RS232 Transceiver.

The RS232 Transceiver section, uses the ever popular MAX232 device from MAXIM semiconductors. Serial communication is a useful aid to debugging microcontroller code. The MAX232 ensures that the correct voltage levels are seen by both the computer and the microcontroller, as well as serving to isolate the two devices somewhat. This section is shown below: -

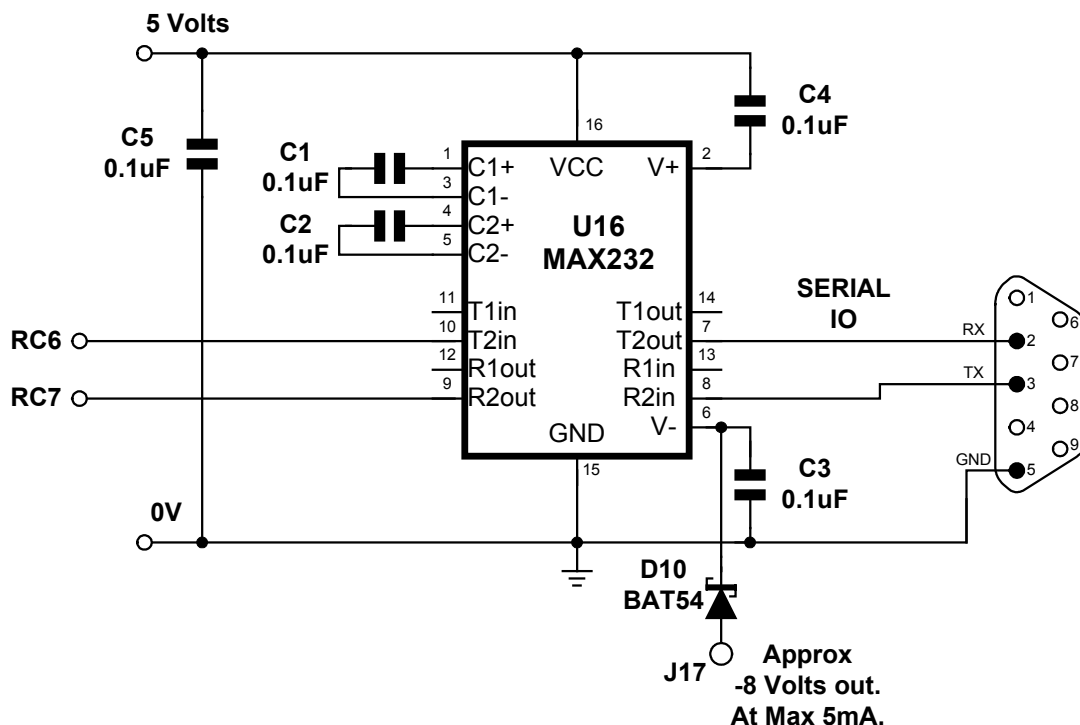

RS232 Transceiver circuit.

The input and output pins of the MAX232 are connected to pins RC6 and RC7 of the PICmicro™. This allows the implementation of the hardware USART for serial IO, as well as a bit-bashed method.

A simple test of the serial port is shown below: -

```
INCLUDE "PROTON_4.INC"      ' Use a 4MHz XTAL
RSOUT "HELLO WORLD"        ' Send some text
Loop:
PRINT RSIN                  ' Display typed characters
GOTO Loop
```

The above program outputs the string "HELLO WORLD" serially. This may be monitored using HyperTerminal or the compiler's build in serial terminal program. It then sits in a loop, displaying on the LCD, characters typed on the computer.

J17 may be used to obtain a weak negative voltage for biasing op-amps etc.

PROTON Development Board MKII

LCDs.

Two types of LCD are supported with the PROTON board, an alphanumeric type based on the Hitachi HD44780 chipset. And a Graphics type based on the Samsung KS0108 chipset.

The PROTON board comes supplied with the alphanumeric type as standard. However, the graphics LCD may be purchased separately from Crownhill Associates.

Each LCD has a relevant socket associated with it. The graphic LCD's socket is supplied when the LCD is purchased from Crownhill (See the relevant section in this manual for details). The smaller of the two sockets is for the alphanumeric LCD.

Alphanumeric LCD.

Shown below is the circuit for the Alphanumeric LCD, and its connections to the PICmicro™.

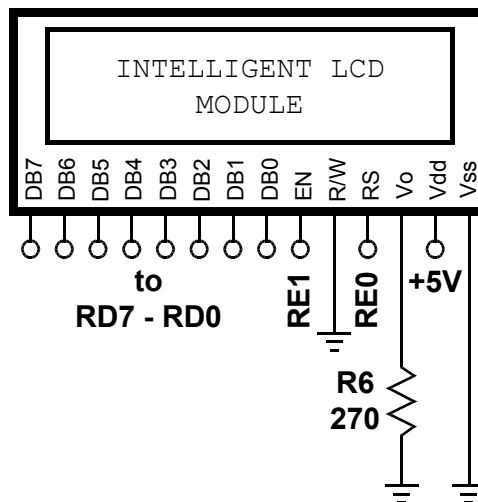

Alphanumeric LCD circuit.

A simple test program is shown below:-

```
INCLUDE "PROTON_4.INC"      ' Use a 4MHz XTAL
CLS
PRINT "HELLO WORLD"        ' Display some text
STOP
```

PROTON Development Board MKII

Graphic LCD.

The graphic LCD's circuit and connections to the PICmicro™ is shown below:-

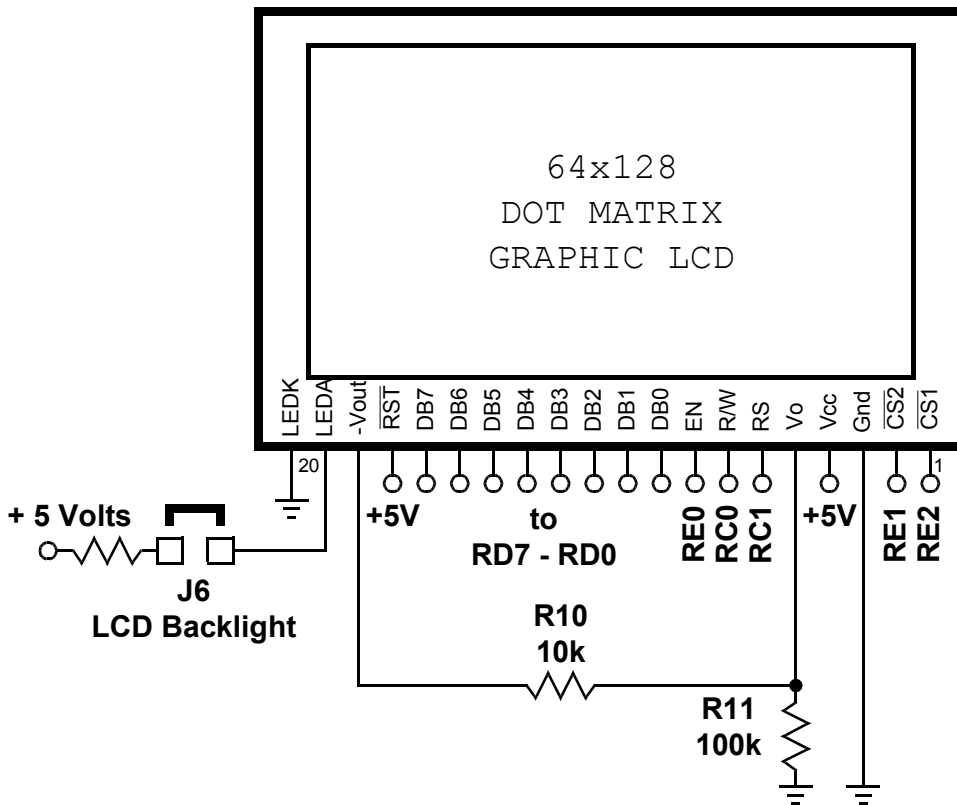

Graphic LCD circuit.

The graphic LCD supported by the PROTON board is a 64 x 128 pixel type, using the Samsung KS0108 chipset. The jumper J6, enables/disables the LCD's backlight. Note that a graphic LCD with backlight facility must be used in conjunction with jumper J6.

A small program demonstrating the LCD is shown below:

```
INCLUDE "PROTON_G4.INT"    ' Use a 4MHz XTAL
CLS
PRINT "HELLO WORLD"      ' Display some text
STOP

INCLUDE "FONT.INC"        ' Add the LCD's Font
```

16-Button Keypad.

The PROTON board has 16-buttons arranged in a keypad matrix, connected to PORTB of the PICmicro™. Resistors R1, R2, R4, and R5, offer a measure of protection in the event that a short may appear on the PIC's IO lines. R3 acts as a pull down resistor for switches S13, S14, S15, and S16. These may then be used as standard push switches. The circuit for the keypad matrix is shown below: -

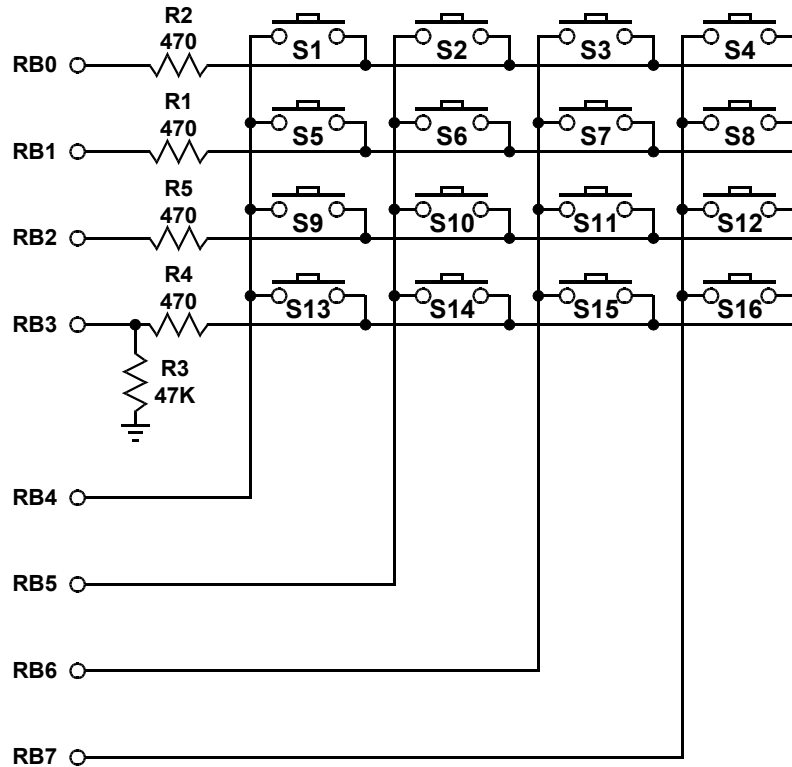

16-Button Keypad circuit.

A small program demonstrating the keypad is shown below: -

```
INCLUDE "PROTON_4.INC"      ' Use a 4MHz XTAL
CLS
Loop:
PRINT AT 1 , 1 , DEC INKEY , " " ' Display the key press
GOTO Loop
```

PROTON Development Board MKII

8 x LEDs.

The eight LEDs are all connected to PORTD of the PICmicro™. These lines are also shared with the LCD. This is the reason why the LEDs appear randomly to illuminate when the LCD is accessed. This can be eliminated by removing the LEDs from circuit using jumper J1.

The circuit for the LEDs is shown below: -

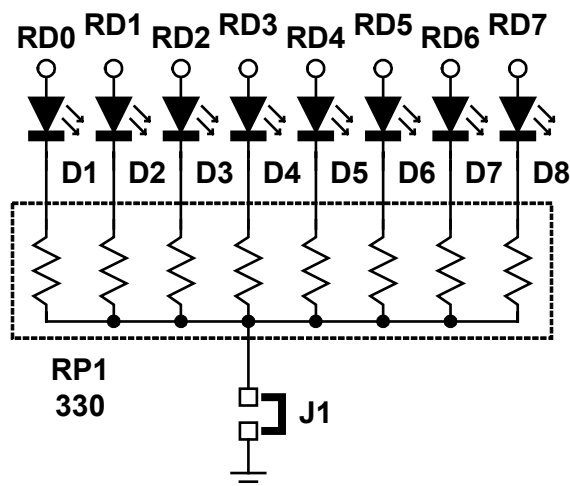

8 x LED circuit.

Resistor network RP1 limits the current supplied to the LEDs, offering a good brightness level at an acceptable current rating.

A program demonstrating the LEDs in operation is shown below: -

```
INCLUDE "PROTON_4.INC"      ' Use a 4MHz XTAL
DIM Loop AS BYTE           ' Define loop variable
SYMBOL LED = PORTD        ' Alias PORTD to LEDES
TRISD = %00000000        ' Set PORTD to all output
Again:
LED = 1                    ' First LED on
DELAYMS 500                ' Delay for .5 seconds
Loop = 1
REPEAT                     ' Loop 7 times
LED = LED << 1             ' Shift LED one to left
DELAYMS 500                ' Delay for .5 seconds
INC Loop
UNTIL Loop = 8             ' Close the loop
GOTO Again
```

PROTON Development Board MKII

100K Potentiometer.

In order to use the PICmicro's ADC, potentiometer VR3 is added to the PROTON board. This is connected to bit 0 of PORTA (AN0), and may be disconnected from circuit by the use of J10.

The circuit for the potentiometer is shown below: -

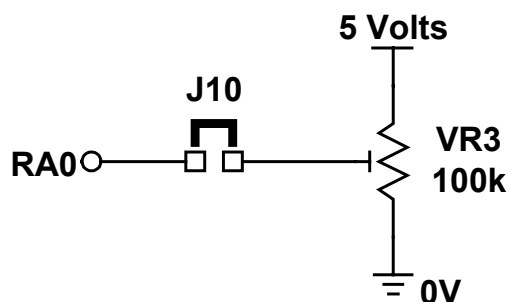

Potentiometer circuit.

A program demonstrating the potentiometer in operation is shown below: -

```
' Program to measure voltage (0-5VDC) and display on LCD
' This program uses the */ operator to scale the ADC result from 0-1023
' to 0-500. Then */ performs a divide by 256 automatically, allowing math which
' would normally exceed the limit of a WORD variable.
```

```
Include "PROTON_4.INC"
```

```
' Define ADC parameters
```

```
ADIN_RES = 10
```

```
' 10-bit result required
```

```
ADIN_TAD = FRC
```

```
' RC OSC chosen
```

```
ADIN_STIME = 50
```

```
' Allow 50us sample time
```

```
DIM ADVAL AS WORD
```

```
' Create ADVAL to store result
```

```
TRISA = %11111111
```

```
' Set PORTA to all input
```

```
ADCON1 = %10000010
```

```
' Set PORTA analogue and right justify result
```

```
DELAYMS 500
```

```
' Wait .5 second
```

```
CLS
```

```
' Clear LCD
```

```
Loop:
```

```
ADVAL = ADIN 0
```

```
' Read channel 0 to adval (0-1023)
```

```
ADVAL = (ADVAL */ 500) >> 2
```

```
' Display the decimal value
```

```
PRINT AT 1,1,"DC Volts= ",DEC (ADVAL/100),".",DEC2 ADVAL," "
```

```
DELAYMS 100
```

```
' Wait .1 second
```

```
GOTO Loop
```

```
' Do it forever
```

PROTON Development Board MKII

PICmicro™ Microcontroller.

The PROTON board has at the heart of it a PIC16F877 microcontroller. This device offers 8k (8192 bytes) of program space, and 368 bytes of user RAM, as well as built in peripherals such as USART, ADC, SPI, I²C, and many more. Each section of the PROTON board is attached in some way to this device. The circuit below illustrates the connections to the various sections.

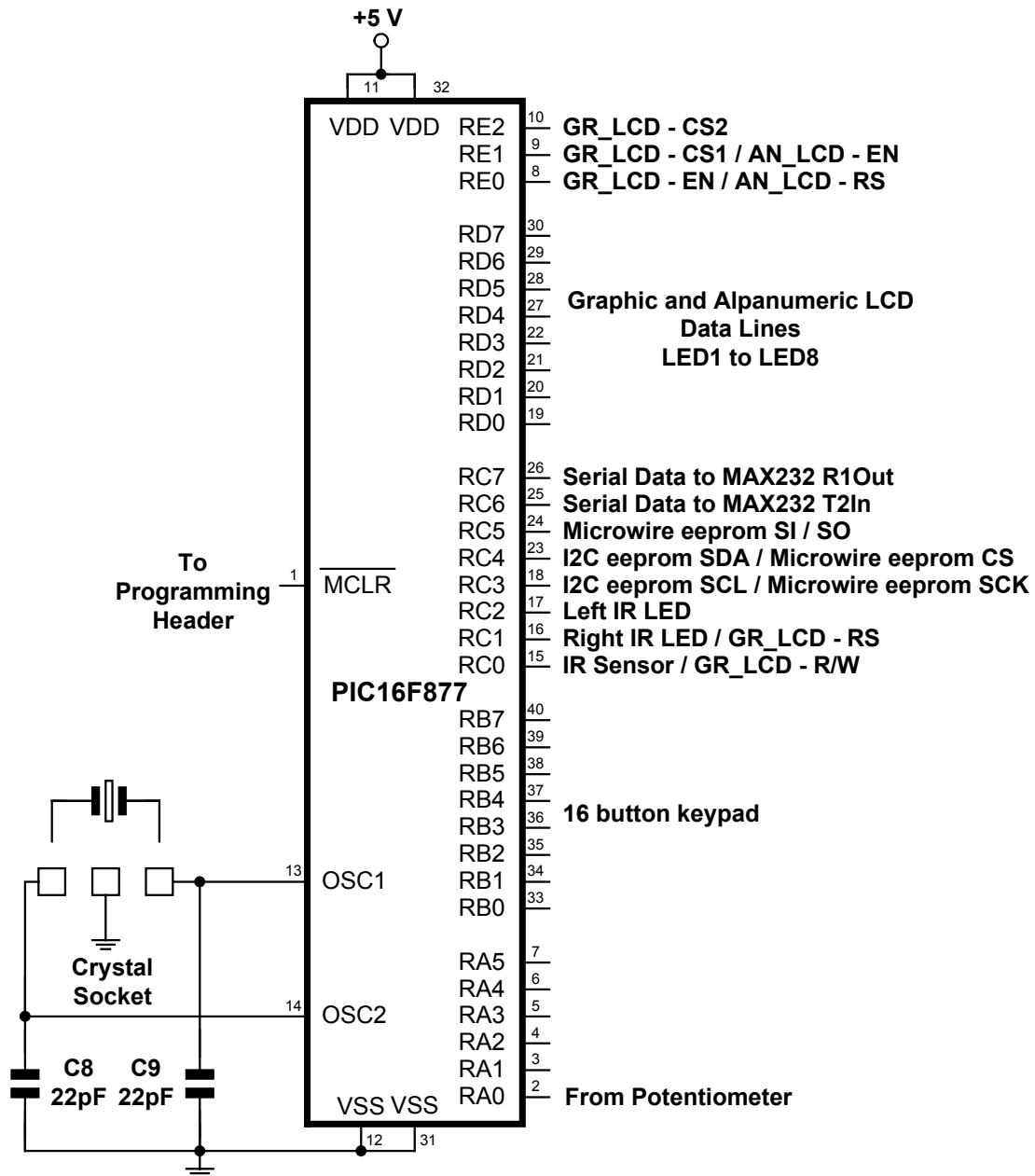

PICmicro™ Microcontroller circuit.

Different frequency crystals or resonators are catered for by inserting the appropriate quartz component in the XTAL Socket. The board also caters for the 3 pin type resonators.

PROTON Development Board MKII

I2C Eeprom.

The PROTON board caters for two types of serial eeprom. An SPI type, and an I²C type. The I²C eeprom (type 24LC128) is supplied with the board. This eeprom has a capacity of 128k-bits, which in byte terms is 16k bytes. The circuit below shows the connections of the I²C eeprom to the PICmicrotm.

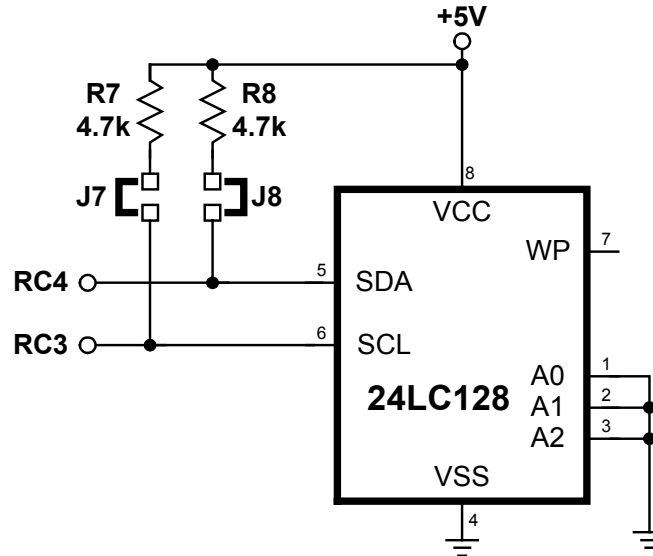

I²C eeprom circuit.

Because the I²C architecture relies on open-collector IO lines, resistors R7, and R8 are in circuit. However, because other devices may need to be attached to pins RC3, and RC4 of the PICmicrotm, these resistors need to be removable. Therefore, jumpers J7, and J8, isolate the relevant resistor. When the I²C eeprom is required these jumpers must be in place. The program below demonstrates writing and reading to the I²C eeprom.

```
INCLUDE "PROTON_4.INC"      ' Use a 4MHz XTAL
CLS
BUSOUT $A0 , 1000 , [123]   ' Write to address 1000
DELAYMS 10                  ' Wait for write to happen
PRINT DEC3 BUSIN $A1 , 1000 ' Read back the address
STOP
```

PROTON Development Board MKII

SPI Eeprom.

SPI eeproms use a different architecture to I²C types, therefore they do not require resistors R7, or R8. SPI eeproms are usually denoted by the component name 25XXX, where XXX is the memory capacity of the eeprom.

A popular SPI eeprom is the 25LC640. This has a capacity of 64k bits, which amounts to 8192k bytes.

Shown below is the circuit for the SPI eeprom section of the PROTON board, and it's connections to the PICmicro™: -

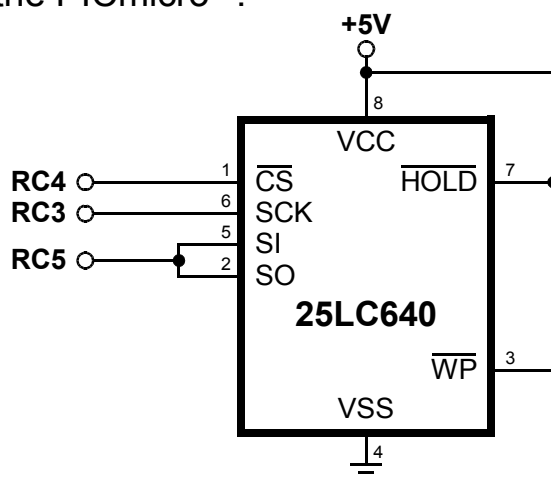

SPI eeprom circuit.

A simple demonstration program for accessing the SPI eeprom is shown below.

```
INCLUDE "PROTON_4.INC"      ' Use a 4MHz XTAL
DIM ADR AS WORD
DIM BYTEIN AS BYTE
CLS
ADR = 1000                  ' Eeprom address 1000
LOW CS                      ' Enable the eeprom
SHOUT SI,SCK,MSBFIRST,[6]  ' Send WRITE ENABLE
TOGGLE CS                   ' Execute the command
' Send address and data value 123
SHOUT SI,SCK,MSBFIRST,[2,ADR.byte1,ADR.byte0,123]
HIGH CS                     ' Disable the eeprom
DELAYMS 5                   ' Allow the eeprom to allocate the byte
LOW CS                      ' Enable the eeprom
' Send READ COMMAND and address
SHOUT SI,SCK,MSBFIRST,[3,ADR.byte1,ADR.byte0]
SHIN SO,SCK,MSBPRE,[BYTEIN] ' Read data
HIGH CS                     ' Disable the eeprom
PRINT DEC BYTEIN
STOP
```

PROTON Development Board MKII

Infrared Transmitters and Receiver.

The PROTON board incorporates an infra-red receiver module, and also two infrared LEDs.

Transistors, Q1 and Q2 act as buffers for the infrared LEDs. Jumpers J4, and J5 isolate the LEDs from the PICmicro™ IO pins. J3 isolates the receiver module.

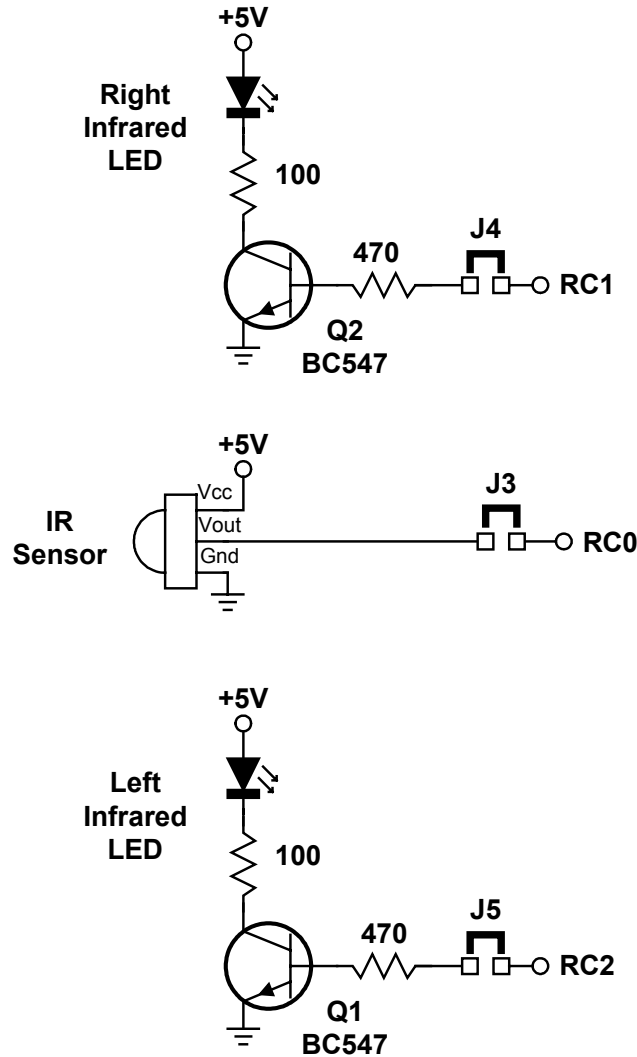

Infra-Red Transmitters / Receiver circuit.

PROTON Development Board MKII

40 pin Microcontroller link socket.

In order for the development area to connect to the PICmicro™ at the heart of the PROTON board, each of its pins is brought out to a line on a 40 pin socket, J1. The connections to the 40 pin socket are illustrated below.

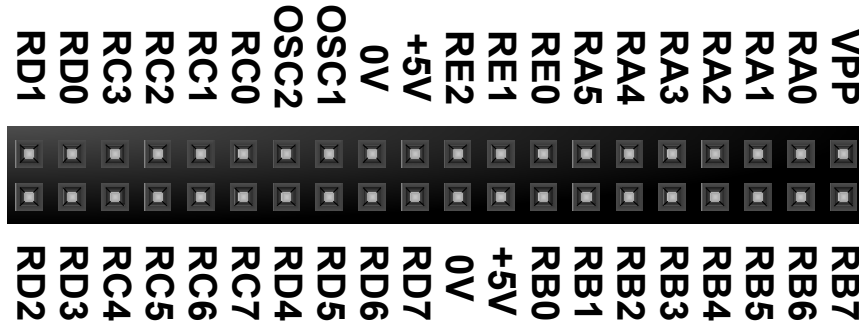

Connecting the breadboard to the 40 pin socket, is a simple matter of wiring. Shown below is a connection to RA0 of the PICmicro™, using one of the pre-cut and formed wires in the Wire Jumper kit available from Crownhill.

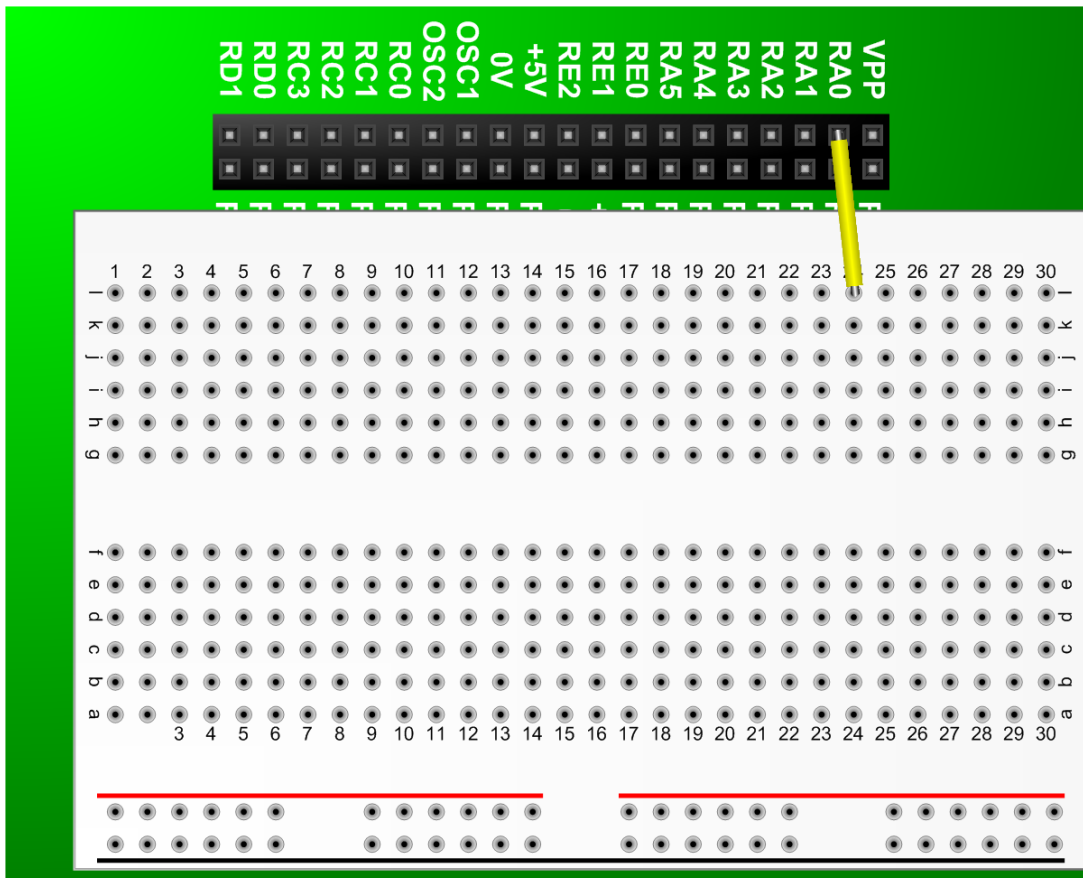

PROTON Development Board MKII

Solderless Breadboard area.

The solderless breadboard area of the PROTON board, makes rapid prototyping possible, as well as re-use of valuable components.

The breadboard is laid out in a standard configuration, however, if you're not familiar with solderless breadboards, the diagram below shows the board as if an X-ray had been taken. You can clearly see the internal connections.

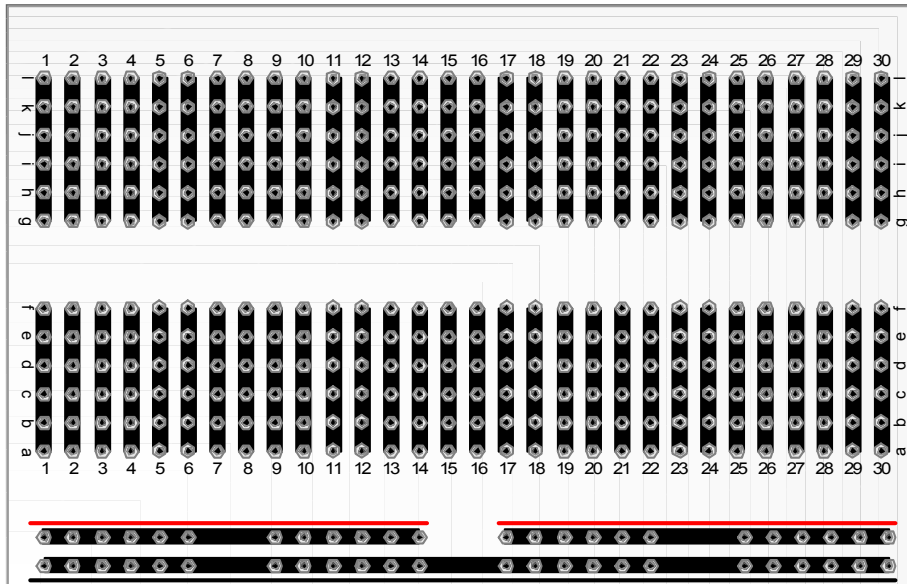

Transparent view of solderless breadboard.

The bottom strip (with a black line below it) is already connected to 0 Volts, and the strip above it (with a red line above it) is connected to +5 Volts. As shown below.

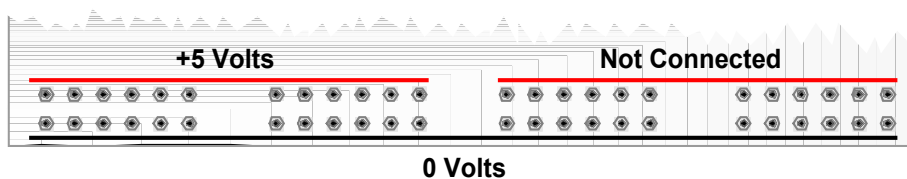

However, when the PROTON board is purchased, the solderless breadboard area and the 40 pin microcontroller link socket are separate from the main board. This allows access to the solder pads, including the unique surface mount area. The PCB layout of the PROTON board reflects exactly the pin arrangement of the solderless breadboard.

In order to use the solderless breadboard, and microcontroller link socket, you will need some basic soldering skills.

PROTON Development Board MKII

The PROTON Board and the PROTON Compilers

The PROTON board was designed primarily with the PROTON compilers in mind. However, this does not bar it from being used with any PICmicro™ language, either high-level, or assembler. But for this section, as in the rest of the manual, we'll stick with the PROTON+ compiler.

The CDROM supplied with the PROTON board, has a LITE version of the PROTON+ compiler. The LITE version is fully functional, but is restricted to 35 lines of code, and only one command per line, as opposed to unlimited lines and multiple commands per line in the full version. This allows a fair appraisal of it's merits, and strengths. Within the LITE version's folder, you will find example software for use with the PROTON board, ranging from simple LED flashing to a demonstration of the hardware USART.

Most of the examples do not require any additional components for them to work, relying on the PROTON board's wealth of on-board peripherals. However, there is one program in particular that requires an extra component to be wired up on the solderless breadboard. This is OWRITE.BAS.

The OWRITE.BAS program, demonstrates measuring the temperature using a Dallas Semiconductors (now MAXIM), DS1820. This requires the inclusion of two components, a DS1820, and a 4.7KΩ resistor. The diagram below shows a possible layout for the circuit.

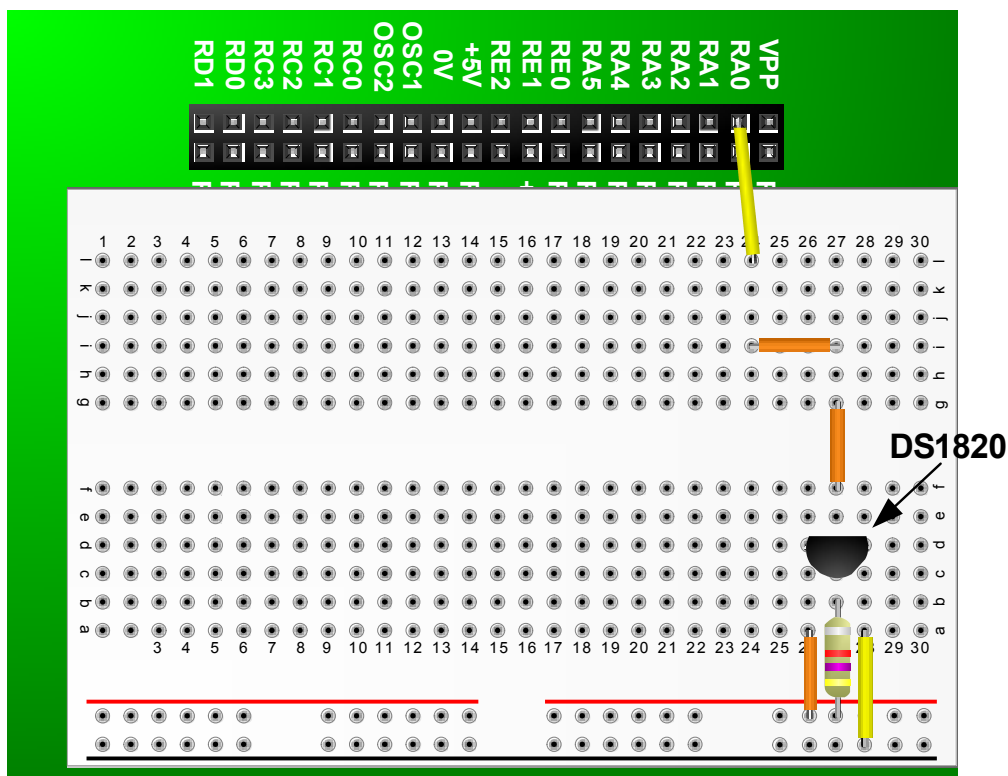

PROTON Development Board MKII

On-Board Serial Bootloader.

The 16F877 PICmicrotm supplied with the PROTON board, has a serial boot-loader pre-programmed into it. What this means is that the device can be programmed using nothing more than the serial port of the PC. We'll take the OWRITE program as an example of this.

Ensure that the PROTON board is connected to the PC using a suitable 9-pin serial cable, and is being supplied with it's correct voltage (6 – 9 Volts). Now load and compile the OWRITE.BAS program.

Using the built-in PIC16F87x bootloader

A boot loader allows the PICmicro to be programmed using a simple serial cable from the computer's COM port.

Before the bootloader may be used, the target PICmicro must be programmed conventionally with one of the bootloader hex files. This is the code that resides in the PIC and intercepts the serial data presented from the PC. The HEX files may be found in the LOADER_HEX folder. Each type of 16F87x PICmicro and crystal combination requires a different hex file, for example, a 16F877 device working with a 20MHz crystal requires the PIC16F877_20.HEX file programmed. There is however, one other requirement, because the configuration fuses are not alterable by the bootloader, you must decide whether to have the watchdog timer enabled or disabled in the target PICmicro. There are two main folders in the LOADER_HEX folder, these are WDT_ON, and WDT_OFF. The WDT_ON folder contains the boot hex files with the watchdog timer enabled, and the WDT_OFF folder contains hex files with the watchdog timer disabled. Remember, the default of the compiler when using a conventional programming method is watchdog timer enabled.

The bootloader is chosen by clicking on the appropriate iconic button, located at the top of the editor. See below: -

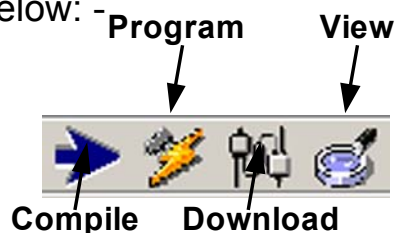

You may choose one of the available serial port on the PC for the attachment of the bootloader, by selecting COM1, COM2, or COM3 in the drop down menu. The default port is COM1. The port, as well as other parameters will be remembered, so there is no need to continually alter the settings.

PROTON Development Board MKII

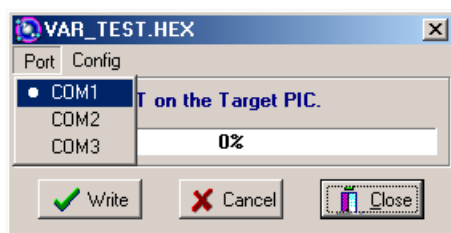

Other aspects of the downloader may also be altered by clicking the CONFIG menu (shown below).

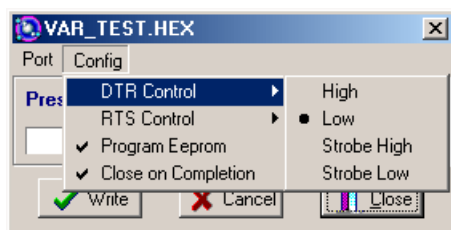

The **DTR CONTROL** option has four settings: -

HIGH. Will set the DTR line high while writing is in progress.

LOW. Will pull the DTR line low while writing is in progress.

STROBE HIGH. Will toggle the DTR line LOW-HIGH-LOW while writing is in progress.

STROBE LOW. Will toggle the DTR line HIGH-LOW-HIGH while writing is in progress.

The **RTS CONTROL** option also has four settings: -

HIGH. Will set the RTS line high while writing is in progress, and keep it high afterwards

LOW. Will pull the RTS line low while writing is in progress.

STROBE HIGH. Will toggle the RTS line LOW-HIGH-LOW while writing is in progress.

STROBE LOW. Will toggle the RTS line HIGH-LOW-HIGH while writing is in progress.

PROGRAM EEPROM. Will program the on-board eeprom along with the main program code, if checked.

CLOSE ON COMPLETION. Will automatically close the bootloader window if a successful write is carried out.

In normal operation, the bootloader will automatically search for the bootloader receiver software in the PICmicro, however, for this to be found, the PICmicro must be RESET or powered up.

PROTON Development Board MKII

You will then be prompted with the message shown below. Clicking on the WRITE button will also start the download process.

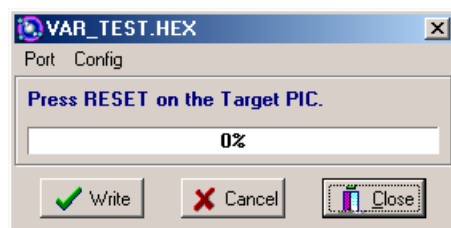

Once the RESET button on the PROTON board is activated, the program will download and run automatically. That's all there is to it.

What is a bootloader?

The PIC16F87x, and all the 16-bit core range of devices have a unique feature, they can program their own FLASH code space while running. All other PICmicro's must be programmed by a device programmer, such as the PIC-START™ or EPIC™ programmers. This self-modifying feature allows a PIC16F87x device to run a program named a bootloader.

A bootloader is a program that resides in the code space of the target PICmicro. It can be activated to allow additional program code to be written to and read from that same target PICmicro. A bootloader consists of 2 elements, connected by a serial cable.

The first part of the bootloader is a program resident on the PICmicro. This program occupies the upper 256 words of the FLASH code space. This small program must be placed into the PICmicro using a conventional programmer.

The program resident in the PICmicro communicates with the second element of the loader over a serial connection. This second program is the bootloader window within the compiler's IDE and is the user interface. It allows the compiled BASIC code to be programmed.

Only the code space and data space may be read and programmed on the target PICmicro. The ID space and CONFIGURATION fuses are not accessible to the bootloader. The configuration fuses must be set at the time the actual loader program is programmed into the PICmicro. Once they are set, they cannot be changed by the bootloader.

The bootloader software resident in the PICmicro, intercepts the reset vector. When the PICmicro powers up, it enters the loader's boot supervisor, this watches the USART's serial input pin for a start bit for 200 milliseconds (ms). If it sees activity during this period, it enters the communications section of the

PROTON Development Board MKII

software to download a program. If it does not see any activity during the 200ms, it starts the user program in the PICmicro.

The interception of the reset vector is accomplished by automatically relocating the first 4 user program words from address's 0 to 3 to a reserved place in the bootloader's code space (within the top 256 words). A jump to the bootloader is then placed at locations 0 to 3. When the loader software running on the PC reads or writes these addresses the values seen are as if the bootloader was not resident and the reset code had not been moved.

The USART's serial pins used by the bootloader are only required when the loader is actually programming the PICmicro. They are unattached while the downloaded user program is running on the target and may be assigned to any other task or serial baud rate, with one exception. As we've already discussed, the bootloader checks the serial input pin at power up and reset, to determine if it should run, or if the user (downloaded) program should run. Therefore, for the user program to run, this pin must not be in the start bit condition when the device is powered up. Make sure the serial in pin (PORTC.7) is in the idle state when the PIC is first powered up.

The serial communication speed is set at 19200 baud. The bootloader program resident in the PICmicro can easily communicate at this speed with an oscillator frequency from 4MHz to 20MHz. This oscillator frequency is determined at the time the loader code is programmed into the target PICmicro. The target PICmicro must then only be run at this frequency in order to be able to communicate with its matching part running on the PC. The bootloader uses no PICmicro resources while the user program is running. All the data memory, RAM, and I/O pins are available to the user program.

However, there are a few considerations that should be noted when writing programs that will be loaded by the bootloader. The first is that the bootloader takes over at power up and any subsequent resets. Any time the program vectors through the reset address, the loader becomes active and watches the RX pin (PORTC.7) for any activity. If there is any action on this pin, the loader will start, and the user program will not execute. Even if there is no activity on this pin, the start of the user program will be delayed by the 200 milliseconds while the bootloader is watching the RX pin.

Another consideration is the fact that the configuration fuses are not alterable by the bootloader. If some programs require the use of the Watchdog Timer and others don't, then separate PICmicro's will be necessary. One PICmicro programmed with the WDT on and one with it off. The same is true for the Power up Timer, Brownout Detect Enable and Oscillator type.

PROTON Development Board MKII

The standard programmed defaults are WATCHDOG TIMER OFF, POWERUP TIMER ON, BROWNOUT DETECT ENABLE ON and HS OSCILLATOR.

The configuration fuses for code protection CANNOT be enabled. The bootloader needs to be able to freely read and write to the PICmicro's code and data space. Therefore, the device cannot be code protected. The bootloader is primarily aimed at development work, any final products that require code protection must be programmed in the conventional way.

The bootloader software occupies the last 256 words of code space. A compiled program is written starting at location 0 and grows upward so the loader's position in memory is not noticeable. You must make sure that the program code does not attempt to enter the upper 256 words of code space. The bootloader inserts its own code at the reset vector and automatically relocates the user's reset code to an area reserved within the top 256 words of memory. Normally, these locations contain a jump to the start-up routine for the user program. However, since the user code is no longer situated at these locations, the user program should not attempt to jump to, or call any routine within the code area between 0 and 3.