

| | |
|--|------|
| terminology | 3-46 |
| data sheet parameters | 3-46 |
| other parameters | 3-47 |
| inductor types | 3-47 |
| advantages of passive networks | 3-48 |
| inductors in passive filters | 3-49 |
| design example : | 3-49 |
| inductors in switched mode power supplies (SMPS) | 3-50 |
| basic topography | 3-50 |
| inductor selection | 3-51 |
| integrated circuit switching elements | 3-52 |
| design example : | 3-52 |
| modelling inductors in SPICE | 3-53 |
| design example : | 3-55 |
| limitations | 3-55 |
| summary | 3-55 |
| EMC design considerations | 3-55 |
| custom inductors | 3-57 |

INDUCTOR APPLICATIONS

Terminology

terminology

Reading a specification for an inductor is considered a simple task, however, there is often some confusion even over the meaning of relatively straight forward parameters. The following list is intended to give a basic understanding of what the parameters stated in the Newport Components Power book are.

data sheet parameters

inductance (L) :

The classical definition of inductance is a constant that relates the magnetic flux linking a circuit to the current flowing in the circuit. The inductance is measured as a reactance to an AC signal at a single frequency (typically 10mV at 1kHz).

maximum DC current (I_{DC}) :

The maximum DC current is defined by Newport Components as the DC current at which the inductance falls to 90% of its nominal value (see figure 1). However, this does not recognise the effect of self heating also contributing to a change in inductance (usually inductance falls as the temperature rises). Consequently the maximum DC current is limited to a temperature rise of 30°C. Therefore the maximum DC current is the value at which the inductance falls to 90% of its nominal value or until its temperature rise reaches 30°C, whichever is sooner. *When making comparisons with non-Newport Inductors it is worth noting that many manufacturers quote a 30% drop which gives the impression of a higher current rating. Newport Inductors will withstand current*

spikes greater than I_{DC} for short periods.

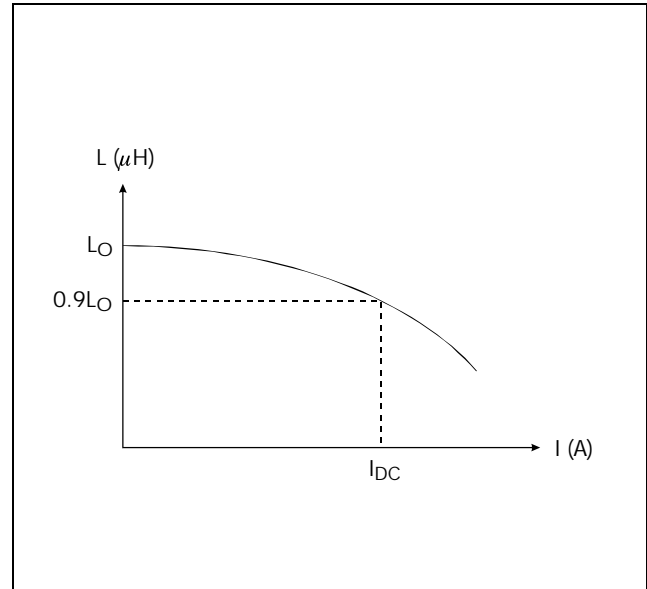

Figure 1 : *Maximum DC Current*

self resonant frequency (f_0) :

Self resonance occurs when the impedance of the inductor is purely resistive. At this frequency the capacitive effect of the wire and the inductance cancel and the relative signal phase across the inductor is zero.

quality factor (Q):

In single reactive components the quality factor is usually the ratio of the reactance and resistance (ideally $Q = \omega L / R_{DC}$, where $\omega = 2\pi f$). The value quoted in the specification is a measured value at a specific frequency, this compensates for the capacitance of the wire (all measurements are made on a HP4191A and HP4192A impedance analyser with a 10mV signal).

inductance temperature coefficient :

The change in inductance per unit temperature change. Measured under zero bias conditions and expressed in parts per million (ppm).

resistance temperature coefficient :

The change in DC wire resistance per unit temperature change. Measured under low DC bias (<1VDC) and expressed in parts per million (ppm).

currie temperature (T_C) :

The temperature beyond which the core material loses its magnetic properties.

magnetic saturation flux density (B_{SAT})

A core parameter which indicates the maximum flux the material can be induced to hold. At this value of flux density all magnetic domains within the core are magnetised and aligned.

other parameters

saturation :

Saturation of an inductor occurs when the core can no longer store magnetic energy, (energy storage = $\frac{1}{2} LI^2$).

EMI :

Electromagnetic interference in inductors refers to the amount of magnetic field radiated away from the inductor itself, that is into "space". This field may cause interference with other magnetically sensitive components and requires consideration in circuit design

and layout and may determine the selection of inductive components in certain applications.

inductor types

pot core
(non-standard components only)

This type of inductor is usually wound by the end user themselves as one advantage of a pot core design is an adjustable air gap which can be used to "trim" the inductance value. Air gap increases saturation current, however, this also usually increases the EMI, with a closed gap pot core the EMI is low. Due to their construction pot cores are usually the most expensive form of inductor. Best suited to applications in which absolute inductance value is critical or requiring high current at high frequencies (typically greater than 1MHz).

bobbin
(1400, 1700, 1800R, series)

This inductor core shape usually supports very low losses, hence high efficiency designs, that can often be wound to permit high current at relatively high inductance values. Bobbins do exhibit higher EMI than toroids or pot cores, however, they are usually lower cost than pot cores, more compact and exhibit higher saturation current than toroidal inductors of comparable physical size.

Suitable for high current designs, such as switching regulators and compact high current filtering, where core saturation is to be avoided.

INDUCTOR APPLICATIONS

Advantages of Passive Networks

toroid (803 and 1900 series)

Toroidal inductors exhibit very low EMI, the shape of the core means the magnetic path flows only within the inductor and hence stray field is virtually eliminated. At high inductance values saturation can occur at relatively low current.

The most common form used in switching regulators due to their EMI properties, toroid inductors are also useful in applications where saturation can be used as either a limiting or feedback mechanism (e.g. chokes, power filters). Toroids can be used at up to several MHz with careful choice of core material.

ferrite rods (1200 series)

The most common and cheapest form of general purpose inductor. This shape can be wound to handle reasonably large current for the body size and have very good saturation characteristics. They are often the most compact inductor form but also exhibit the highest radiated field of all the inductor core forms.

These are general purpose inductors often used for line filtering, current bleeding and passive network construction. Suitable for DC to high frequency applications.

advantages of passive networks

It is easy in the "silicon age" to dismiss inductors as circuit elements in favour of what are considered cheaper, physically

smaller and lighter active networks. However, there are many properties of inductors which cannot be produced using "cheap" silicon, one that is immediately brought to mind is use in power circuitry. Another area in which an inductor may prove to be cheaper is in a simple filter circuit, active filters are usually considerably more complex and often relatively expensive to implement as simple low order filters compared to passive inductive designs.

At high frequencies, silicon and RC networks become limited, stray capacitance and transistor switching frequencies can restrict design capability and increase cost, amplifier stability can also cause serious problems and grounding configurations require special attention. While not alleviating all the problems associated with high frequency design, low DC resistance of inductors are easily characterised and predictable frequency responses can make circuit design and analysis of circuit behaviour easier.

There are certainly some definite advantages in using inductors in modern circuit designs and these passive elements should not be neglected. The following design notes give some basic ideas for use of Newport Components range of inductors. The designs can be used as shown or alternatively the basic ideas adapted to the readers own requirement. The notes are not exhaustive and we welcome feedback and application ideas from any customers, similarly we are always willing to discuss your requirement and can, if required, custom design an inductor for your application.

inductors in passive filters

simple filters

Simple filters can be easily constructed with inductor and capacitor elements. These filters have the advantage of being easy to calculate and characterise the frequency response. They exhibit few of the secondary effects and stability problems associated with their active counterparts. In power line filtering, inductors and relatively small capacitors can be used to produce a smoothed ripple from a spiked input response, ideal for reducing noise in switching regulator circuits and power lines in noisy environments.

Simple L, T and π section filters can be constructed to provide low, high and band pass functions (see figure 2). There are many texts on this subject and these should be consulted for details on more complex filters and interaction between sections. These pages are simply illustrative of applications for Newport Components inductor parts.

design example :

filtering beat frequencies from paralleled DC-DC converters

When standard DC-DC converters are connected in parallel, if there is no synchronising capability, beat frequencies and harmonic frequencies associated with the parts can produce noise and power level fluctuations exceeding the ripple of each individual converter. At Newport Components we recommend that to filter out this extra noise, and in fact reduce total ripple, a simple inductor be added to the output of each

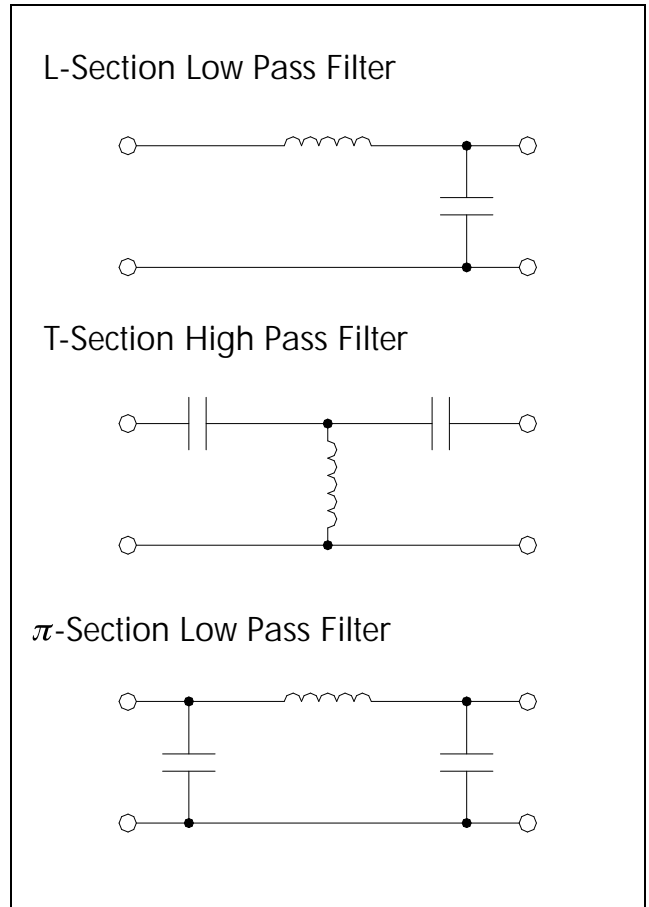

Figure 2 : *Simple Filter Construction*

DC-DC converter, coupled with a common capacitor for all paralleled channels (see figure 3). This also has the added benefit of reducing the voltage drop associated with RC Networks.

Choice of inductor will depend on output current, typically each inductor should be capable of handling at least twice the DC current output from each converter and exhibit low DC resistance. The capacitor value should be chosen to best suit the typical oscillator frequency of the DC-DC converter and the level of noise reduction required. It should be noted that a capacitance of too high a value could cause start up problems in the DC-DC converters.

INDUCTOR APPLICATIONS

Inductors in Switched Mode Power Supplies

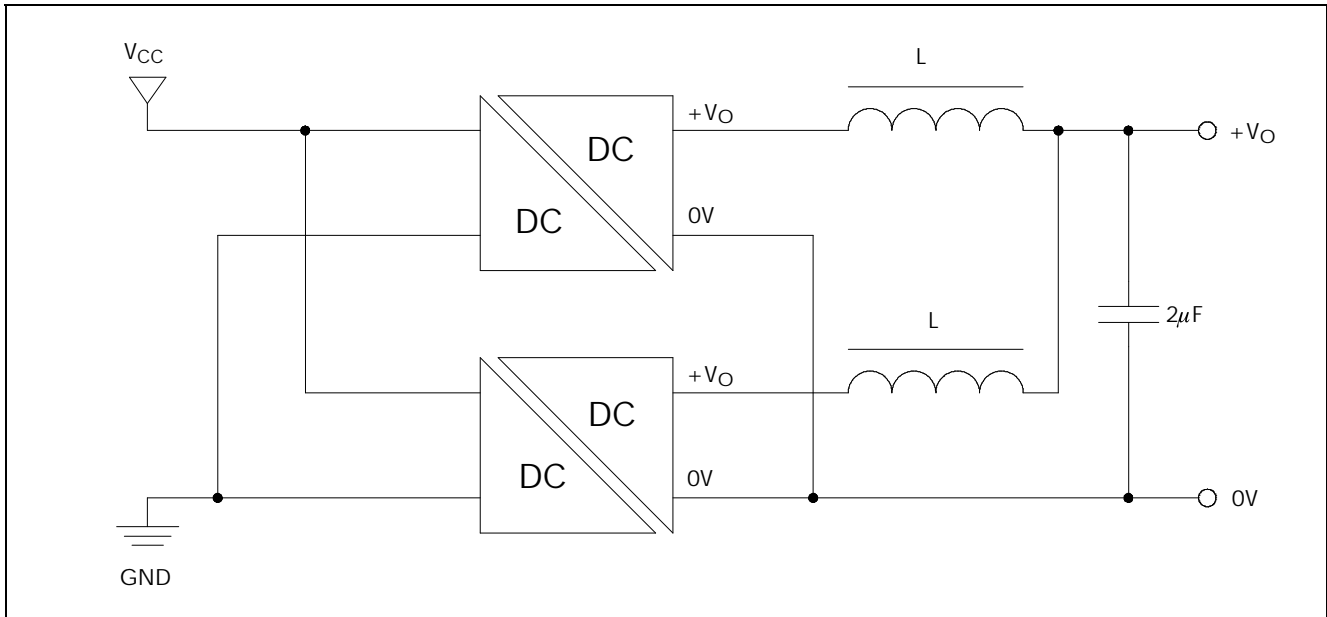

Figure 3 : Parallel DC-DC Converters

If the output capacitance and switching frequency of the DC-DC converter is known it should be possible to calculate accurately the required inductor and capacitor values given the required cut-off frequency. This is performed using the output capacitor of the DC-DC converter as the first part of a π filter, the external inductor and capacitor complete

| DC-DC Product Range | Output Voltage (V) | Inductance (mH) | Inductor Part Number |
|---------------------|--------------------|-----------------|----------------------|
| LME | 3.3 | 33 | 17 333 |
| NMA | 5 | 47 | 17 473 |
| NME | 9 | 100 | 17 104 |
| NMD | 12 | 220 | 17 224 |
| NMH | 15 | 330 | 17 334 |
| NMV | | | |

Table 1 : Filter Inductors

the π . Table 1 gives some recommended values for Newport Components range of DC-DC converters (typical output capacitance $1\mu\text{F}$).

inductors in switched mode power supplies (SMPS)

There are many silicon switching circuits available on the market from most analog silicon vendors (Maxim, Linear Technology, Motorola etc.). All the design notes which accompany these devices recognise the importance of correct inductor selection to achieve the optimum performance of the SMPS design.

basic topography

The majority of switching regulator ICs operate a "pulse skipping" method of regulation. This employs a free running oscillator and a switch to control the oscillator as a

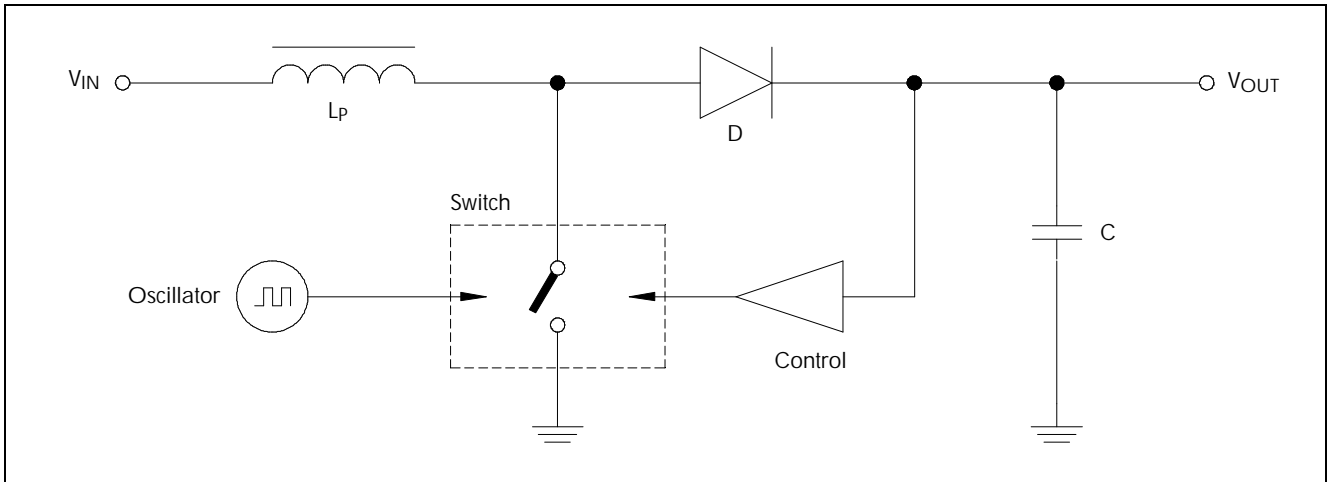

Figure 4 : *Basic Boost Converter*

driver for an internal or external power switch. The circuit is controlled by a feedback comparator, the switch driving the output when the circuit falls below the desired output level and remaining off once the level is exceeded (see figure 4).

There are many configurations for using inductors and transformers in this type of SMPS, however, here the boost regulator will only be considered for our example.

inductor selection

The inductance value for a switching regulator must be high enough to prevent excessive current through the diode and low enough to store sufficient energy in the core. The DC resistance should be low to reduce losses and prevent self heating. The core must also be capable of storing the required energy without saturating. For general purpose use bobbin wound inductors are excellent for most cases, however, in EMI sensitive applications a toroid may be preferable.

The peak current (I_{PK}) and inductance (L_P)

value should be calculated for two worse case conditions (i.e. maximum and minimum values of I_{PK} and L_P). The final choice should be an inductor whose inductance is in between the limits of the calculated values and which has a DC current rating in excess of the maximum peak current calculated.

$$(1) \quad I_{PK} = \frac{4 I_{OUT} (V_{OUT} - V_D)}{(V_{IN} - V_{SW} - V_D)}$$

$$(2) \quad L_P = \frac{t_{ON} (V_{IN} - V_{SW} - V_{OUT})}{I_{PK}}$$

Where V_{OUT} is the required output voltage, V_{IN} is the input supply voltage, I_{OUT} is the required output current (load current), V_{SW} is the voltage drop across the switching element and V_D is the voltage drop in the diode

INDUCTOR APPLICATIONS

Integrated Circuit Switching Elements

| IC Part Number | Inductor Part Number | DC Resistance (Ω) | Vin (V) | Vout (V) | Power Output (W) |
|----------------|----------------------|----------------------------|---------|----------|------------------|
| LT1073-5 | 17 104 | 0.310 | 1.5 | 5 | 0.2 |
| LT1110-12 | 18 223 | 0.020 | 3 | 12 | 0.5 |
| MAX643 | 19 103 | 0.020 | 5 | 15 | 4.5 |
| LT1170 | 19 472 | 0.018 | -20 | -5.2 | 10 |

Table 2 : SMPS IC Parts and Suitable Inductors

integrated circuit switching elements

Table 2 gives some of the common IC switching elements and recommended Newport Components inductors for the given output requirements.

design example :

500mW SMPS using MAX631 and 1800R series inductors

The MAX631 is one of the simplest switching

regulator ICs to use as this contains all circuit functions except for the output capacitor and boost inductor (figure 5). The circuit is a 5V step-up boost regulator with a wide input range from the start-up voltage to around 4.5V. The performance quoted below was achieved using radial leaded inductors and a standard DIL IC.

Note: The quoted maximum power rating of many IC switching regulators are only applicable at high output voltage (i.e. low peak current). Consequently if trying to produce power at low output voltage (i.e. less than

| Inductor Part Number | Inductance (μ H) | Start-up Voltage (V) | Output Current (mA) | Efficiency (%) |
|----------------------|-----------------------|----------------------|---------------------|----------------|
| 18R224 | 220 | 3.0 | 50 | 75 |
| 18R224 | 220 | 3.4 | 100 | 67 |
| 18R334 | 330 | 3.0 | 50 | 75 |
| 18R334 | 330 | 3.4 | 100 | 67 |
| 18R474 | 470 | 3.0 | 50 | 76 |
| 18R474 | 470 | 3.6 | 100 | 66 |

Table 3 : Inductor Selection For MAX631 IC

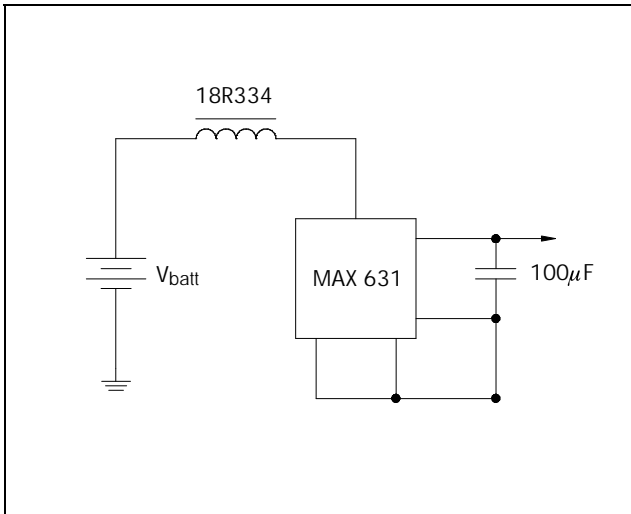

Figure 5 : MAX631 and 1800R Series

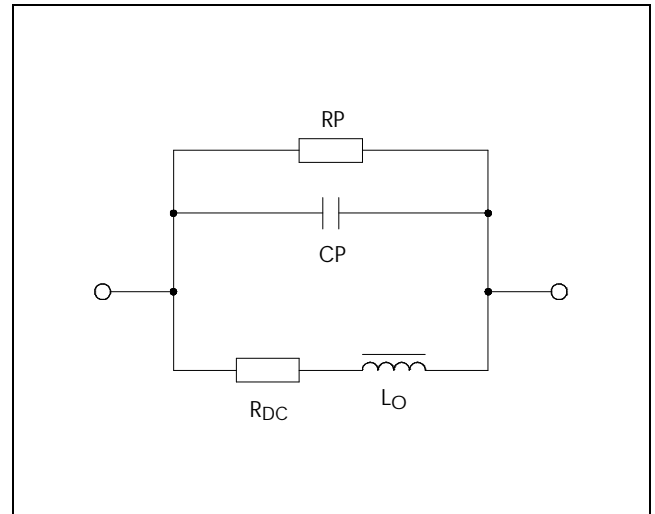

Figure 6 : Equivalent Inductor Circuit

12V), use a higher power rated switching circuit or external switching transistor.

modelling inductors in SPICE

If a SPICE simulation of an inductor is required the simple standard value may not be adequate for all occasions, particularly in situations where the inductor is being used either near its maximum DC current value or when operated at near resonant frequency. In a circuit using many low resistance parts or where low resistance is significant, the effect of the DC resistance of the inductor may be noticeable in the circuit, especially when using high value inductors that have high DC resistance. The specification for an inductor gives sufficient data to accurately model some of the more complex effects of an inductor in a circuit.

An inductor model can be constructed from 4 passive elements, an ideal series inductor and resistor, a parallel capacitor and parallel resistor (see figure 6). The value of the series resistor is defined by the DC resistance value

in the device specification (e.g. for a 1900 series 100µH inductor, $R_{DC}=0.065\Omega$). The value of the parallel capacitor can be derived from the self resonant frequency (f_0) of the part, since this is the point at which the reactance of the inductor is zero (i.e. the impedance is purely resistive). At self resonance the capacitance is given by;

$$(3) \quad C_P = \frac{1}{(2\pi f_0)^2 L_O}$$

Magnetic core loss is modelled as a parallel resistor (R_P) across the terminals. The value can be calculated from the quality factor (Q);

$$(4) \quad R_P = Q (2\pi f_0) L_O$$

This parallel resistor limits the simulated self resonance rising to 'infinity'. The model with these four basic circuit elements models the inductors impedance and phase behaviour over a wide frequency range (see figures 7 and 8).

The inductance value is not constant as the DC current through the device reduces its inductance, since part of the core is

INDUCTOR APPLICATIONS

Modelling Inductors in SPICE

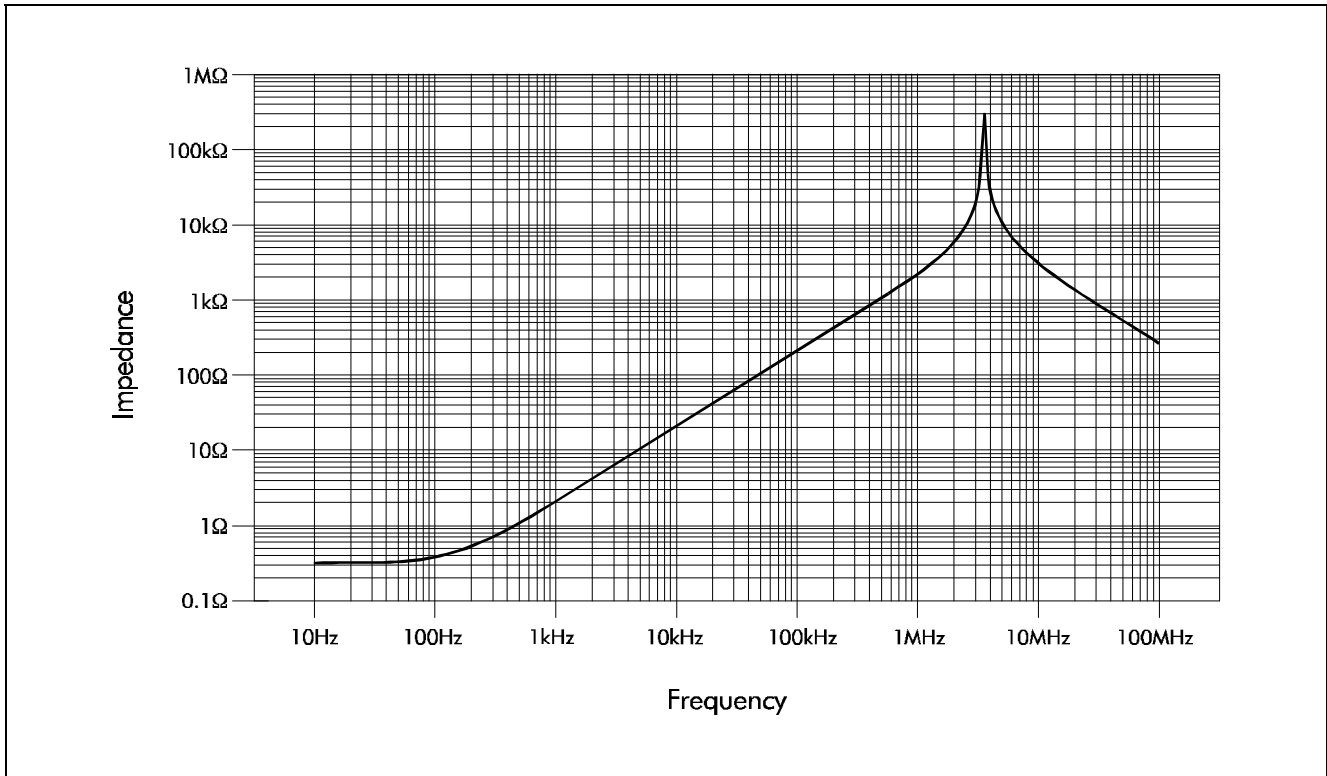

Figure 7 : 18R 334 Impedance Simulation

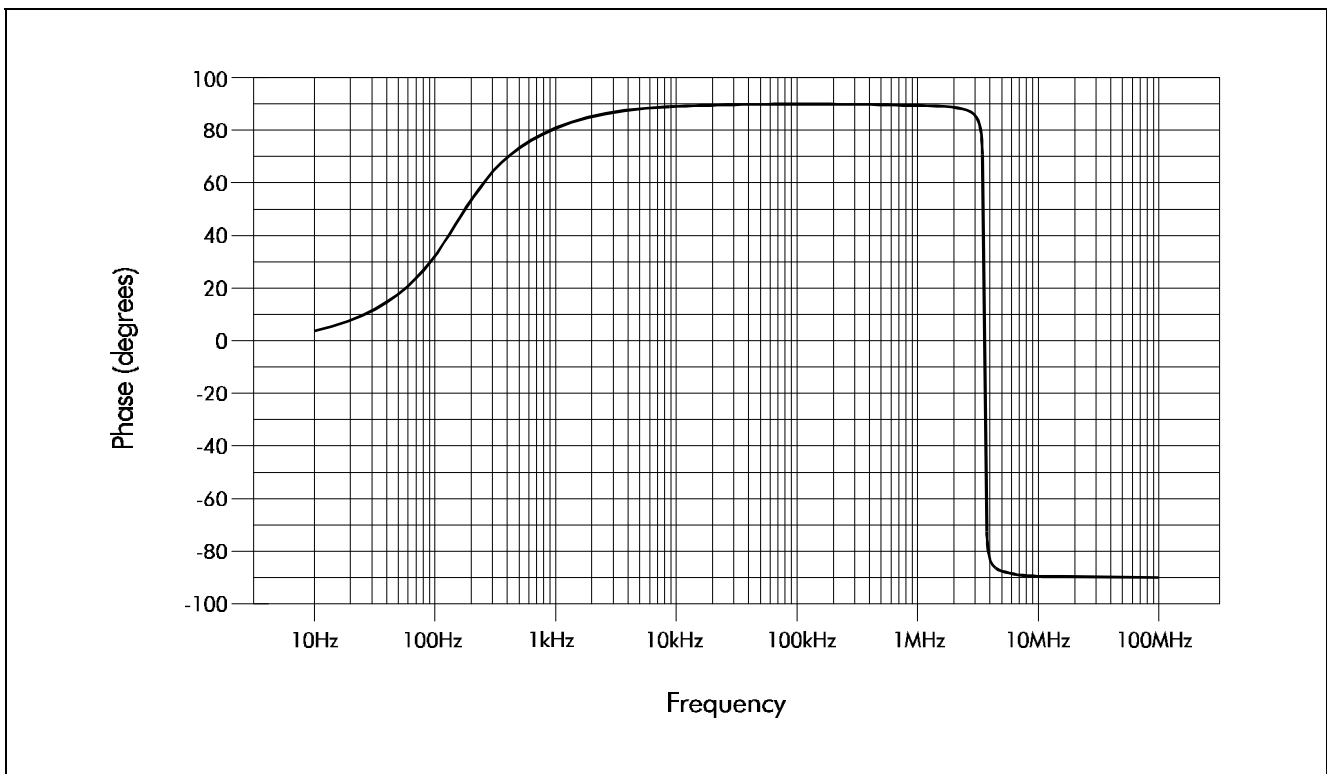

Figure 8 : 18R 334 Phase Simulation

magnetised (figure 1). The standard inductor model in version 2G6 of SPICE can accommodate this effect as a polynomial expression for the inductance as a function of current (equation 5), this can be entered in the standard inductor description in SPICE.

$$(5) \quad L_1 = L_0 + L_1 I + L_2 I^2 + \dots + L_n I^n$$

Where $n \leq 20$.

A simple 2nd order polynomial is sufficient to model this effect and the maximum DC current value can be used to determine the coefficient, L_2 . If the inductance is 90% of its nominal value, L_0 , at the maximum DC current, I_{DC} , then the polynomial equation is;

$$(6) \quad 0.9L_0 = L_0 + L_2 I_{DC}^2$$

Hence the coefficient is given by;

$$(7) \quad L_2 = - \frac{0.1L_0}{I_{DC}^2}$$

An accurate and relatively complex model for an inductor can now be constructed using data sheet values only, hence no additional measurements by the user are required.

design example :

SPICE 2G6 example

The following example is a model for a 1800R series $330\mu\text{H}$ inductor (18R 334) where $L_0 = 330\mu\text{H}$, $R_{DC} = 0.315\Omega$, $I_{DC} = 0.73\text{A}$, $Q = 49$ and $f_0 = 3.57\text{MHz}$.

```
.SUBCKT L18R334 1 2
LO 3 2 POLY 330E -6 0 -6.19E -5
RDC 1 3 0.315
CP 1 2 6.02E -12
RP 1 2 363K
.ENDS L18R334
```

limitations

The above model is now quite sophisticated for an inductive element, however, there are still limitations and this should be borne in mind. The model assumes that there is no variance of resistance and capacitance with DC current, at low values of these parameters this may be adequate as these will tend to be swamped by the rest of the circuit. The major limitation is in the lack of temperature modelling of the inductor, however, this is a general limitation of SPICE. Some temperature modelling for the resistor could be incorporated, however, the heating effect of the power dissipated in the inductor (I^2R term) is not modelled.

summary

It is possible to simulate several complex aspects of inductor operation using only 3 additional passive elements and a simple polynomial expression. The resulting model gives accurate inductor simulations in SPICE over a wide range of operating conditions with a minimal increase in computation time (only one extra node is introduced).

EMC design considerations

The imminent EC regulations regarding electromagnetic compatibility (EMC) will effect many aspects of circuit and system design.

INDUCTOR APPLICATIONS

EMC Design Considerations

However, there are many considerations that can be applied generally to reduce both the emissions from and susceptibility to electromagnetic interference (EMI).

There are many areas where the use of inductors in decoupling and filtering applications will help. However, there may also be situations where the inductive element in a switching circuit is the major cause of EMI. As a manufacturer Newport Components is committed to minimising emissions from its own components and to helping its customers achieve EMC compatibility by correct component choice and design, to this end we have compiled the following list of general design considerations.

- Reduce high frequency (particularly radio frequency) loops in supply lines.
- De-couple supply lines at local boundaries (use RCL filters with $Q \leq 2$).
- Use low pass filters on signal lines to reduce band width to signal minimum.
- Keep return and feed loops close on wide band width signal lines.
- Terminate lines carrying HF or RF signals correctly (this minimises reflection, ringing and overshoot).
- Avoid slit apertures in pcb layout, particularly in ground planes or near current paths.
- Use common mode chokes between current carrying and signal lines to increase coupling and cancel stray fields.

- Use discrete components and filters where possible.
- Ensure filtering of cables and over voltage protection (this is especially true of cabling that is external to the system, if possible all external cabling should be isolated at the equipment boundary).
- Isolate individual systems where possible (especially analogue and digital systems, on both power supply and signal lines).
- If available, use shielding on fast switching circuits, mains power supply components and low power circuitry.

In general, keeping the band width of all parts of the system to a minimum and isolating circuits where possible reduces susceptibility and emissions.

Inductors can be used for both correct termination and filtering of signal and power lines (the 1900 series in particular is suitable for filtering the higher frequency EMI components on high current power lines). Within the circuit the choice of material and construction can be changed. If a circuit is having problems from a rod inductor, a bobbin may be a suitable replacement without losing the saturation properties a rod core shape offers. Likewise if in a switching circuit a bobbin or pot core is proving troublesome, a suitable toroid may be available or could be designed specifically for the application by Newport Components.

custom inductors

Custom versions of all the standard product ranges are available. As well as the core forms used in our standard range, Newport Components have a wide experience of custom designs on other core type such as pot

cores and E shapes. If you have any requirement for an application specific inductor not covered by the data enclosed, call our technical sales desk for information on a custom inductor solution.

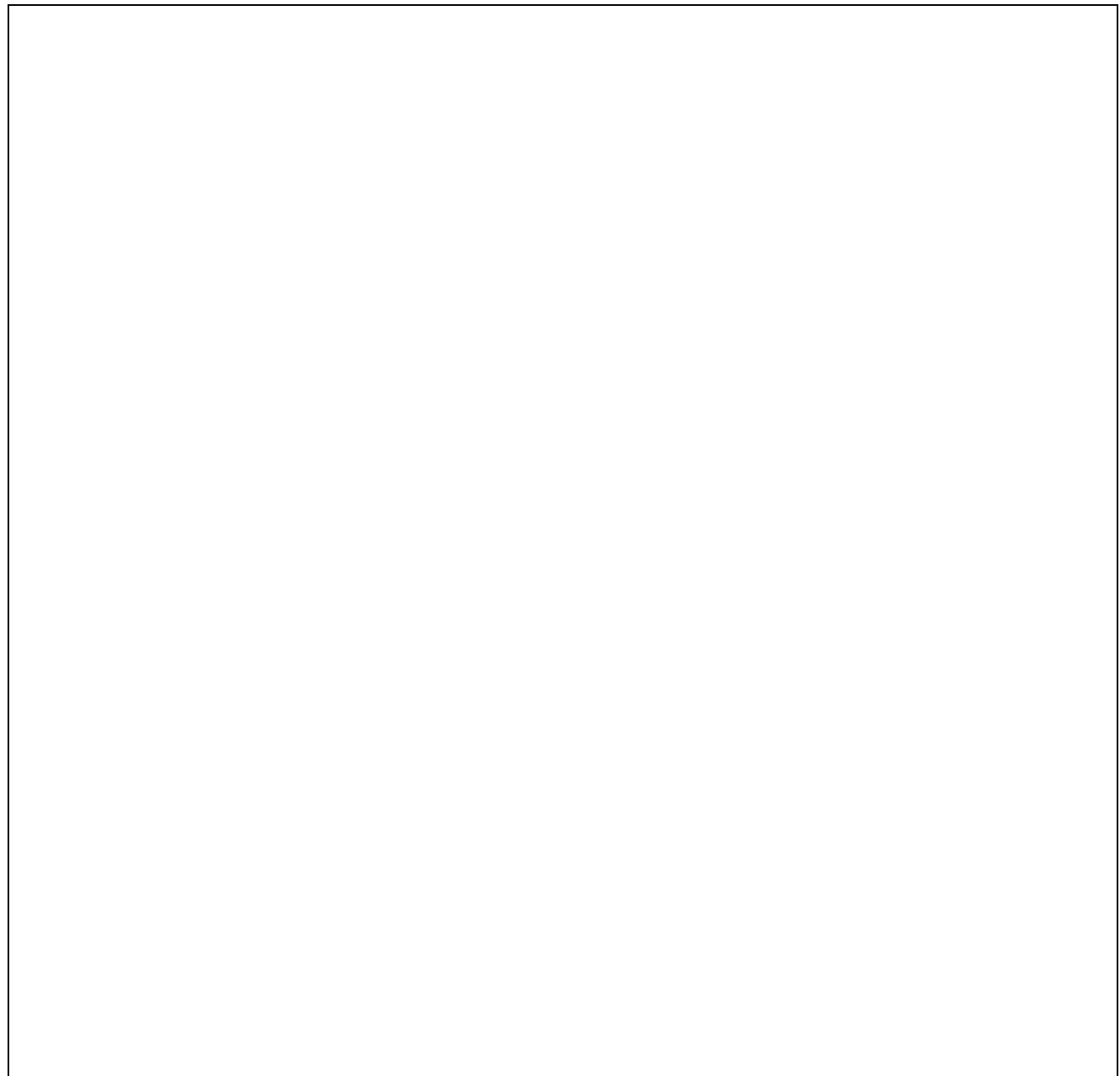

3 APPLICATIONS