

Power MOSFET Gate Driver Circuits using High Current Super- β Transistors

6A Pulse Rated SOT23 Transistors for High Frequency MOSFET Interfacing

Neil Chadderton

The power MOSFET is commonly presented and regarded as a voltage driven device, and as such there is a natural expectation that it can be driven from any pulse source, irrespective of that source's energy, or current capability.

This assumption is partly justified, if the system in question only pulses or switches the MOSFET at a low frequency, or in pure DC circuits, where the transistor may only be used in a toggled state. However, for typical switching frequencies from several kHz upwards, attention must be paid to the gate drive requirements to ensure efficient and "saturated" switching of the MOSFET. This must be considered as the gate-source (g-s) circuit is, to a first approximation, essentially a CR network; comprising the g-s capacitance, and the resistance of the metallic/silicon interconnects. To this network must be added the effective resistance, or source impedance of the gate driver circuitry, and for true assessments, consideration of the drain-gate (d-g) capacitance and the Miller effect. Due to this network, the g-s voltage follows an exponential curve as the C elements charge, and so, either sufficient time must be given to allow this voltage to reach its target value

(thus limiting the operating frequency and increasing the time spent in the linear region thereby producing high switching losses), or the "R" element must be minimised.

As a guide, the input capacitance of power MOSFETs ranges from a few hundred picofarads to tens of nanofarads. This capacitance is increased by the effective amplification of the drain-gate capacitance by the voltage gain of the circuit (Miller effect), such that the apparent capacitive component of the CR network assumes a value of 2 to 5 times the value of the datasheet stated C_{iss} . As this amplification effect is so circuit/bias condition dependent, a useful tool has been developed that considers the amount of gate charge required to meet a certain condition. Figure 1 shows a chart illustrating the gate charge required to switch the ZVN4306A (a 220m Ω , 1A continuous TO92 part), and this parameter's dependence on the Miller effect as the drain voltage increases.

As the operating frequency of switched mode power supplies increases, due to the need for less weight and product volume demands smaller inductors and capacitors, the MOSFET's required gate

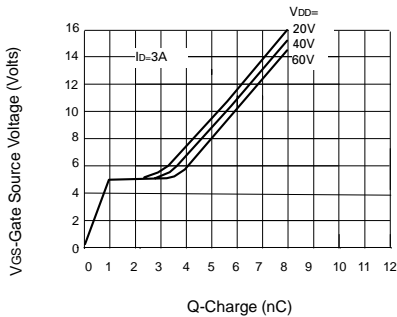

Figure 1
Gate Charge Curves for the ZVN4306A; a 1A DC rated 220mΩ E-Line (TO92) Style MOSFET.

voltage must be driven to its final value in as short a period as possible (within EMI constraints) to minimise switching losses. For a given value of required gate charge, this means that the current capability of the gate drive circuitry must be carefully considered.

As examples of the current required from the driver stage, and using the gate charge curves as a source:

i) A typical 100V, 300mΩ TO220 power MOSFET requires approximately 8nC, which for a switching time of say 20ns, leads to a current requirement of 400mA.

ii) A typical 500V, 900mΩ TO220 power MOSFET needs around 30nC, which could lead to a current requirement of 1.5A.

Obviously, paralleled MOSFETs are another concern, but a high current source could be used with the appropriate shared gate drive to reduce component count in this application

also.

It is necessary therefore, that the gate driver circuitry acts as a low impedance voltage source, to enable the gate capacitance to be charged and discharged as quickly as possible. It must also have the capability of sourcing and sinking high transient gate currents - possibly several amps, in tens of nanoseconds. Standard logic family gates, and even the output stages of switch mode controller ICs are rarely able to provide this requirement and so would be unable to drive power MOSFETs in many applications. To provide an interface between the logic/PWM and the MOSFET, a high speed, high current capable (though not necessarily high power) buffer is therefore required.

The gate drive requirement is met by the complimentary emitter follower circuit shown in Figure 2, which should be constructed with transistors possessing

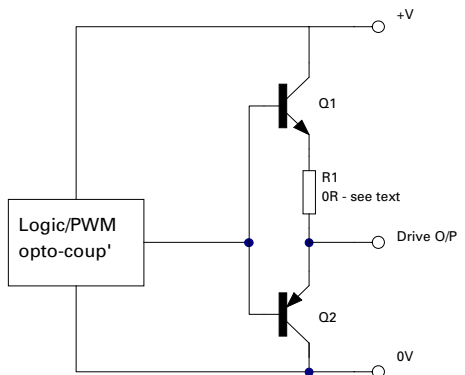

Figure 2
Complimentary Emitter Follower Gate Driver.

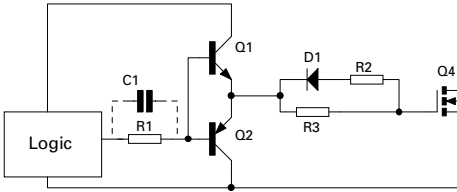

Figure 3
Complimentary Emitter Follower Gate Driver.

a high current capability (eg significant current gain at high collector currents), high F_T (as a benchmark to a fast switching capability), and ideally high gain. As the driver transistors only supply current while the capacitance is charging or discharging, the power capability (essentially determined by the package characteristics) is quite low, and can be tolerated by the smaller through-hole and surface mount packages.

By adjusting the amount of resistance in the charge path as shown, it is possible to delay the turn-on time. This may be necessary in some instances to prevent cross-conduction in push-pull output stages, or to decrease dV/dT to ensure compliance with EMI/RFI regulations.

This basic circuit can be adapted for different circuit topologies and performance requirements as shown in Figures 3, 4 and 5. Figure 3 shows another method of introducing unequal turn-on/turn-off times; Figure 4 shows a level shifted driver for a PMOS device;

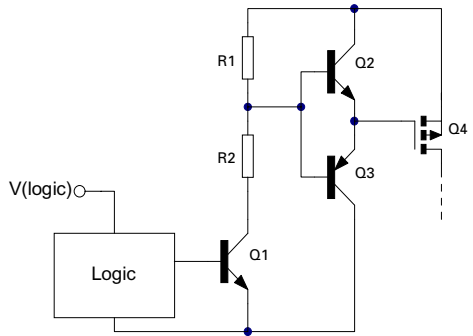

Figure 4
Level Shifted PMOS Gate Driver.

and Figure 5 a method of maintaining the correct drive level and drive phase, when deriving a control signal from a 5V logic based controller, by driving the emitter of a fast switching pre-driver transistor. This can either be a ZTX314 for a through-hole design, or a FMMT2369A for a surface mount version.

Other variations have been devised

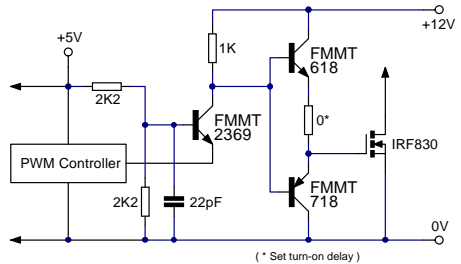

Figure 5
Complimentary Emitter Follower Gate Driver using Emitter Driven Switching Transistor to Retain Phasing.

including complimentary drivers for level shift transformers, and for analogue applications employing op-amp driven voltage followers.

Table 1 presents some of the transistors available from ZETEX, that are suitable for the gate driver application. The SOT23 package used by ZETEX possesses a power dissipation figure of 500mW for the FMMT489/589, or 625mW for the FMMT618/718 (see Note 1) - the latter being approximately twice that available from conventional SOT23 devices. This feature means that driver circuits previously effected with SOT89 packaged transistors can now take advantage of the smaller, lighter and more cost effective SOT23 range. The charts shown in Figures 6 and 7 illustrate the high current h_{FE} capability of the FMMT618 and FMMT718 transistors (also applicable to the through-hole versions - ZTX618 and ZTX718) which,

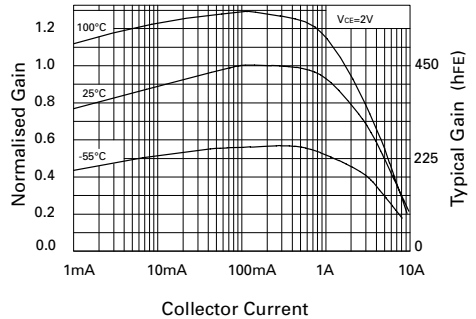

Figure 6
 h_{FE} Profile for the FMMT618.

with transition frequencies around 150MHz, guarantees high current drive integrity at the switching frequencies being demanded by modern power supply solutions.

Figures 8 and 9 are oscillographs

Device	Polarity	Package	$B_{V_{CE0}}$	I_C (DC)	I_{CM}	$h_{FE(mb)}^2$
FMMT489	NPN	SOT23	30	1	4	200
FMMT589	PNP	SOT23	30	1	2	200
FMMT618	NPN	SOT23	20	2.5	6	450
FMMT718	PNP	SOT23	20	1.5	6	450
ZTX618	NPN	E-Line	25	3.5	10	450
ZTX718	PNP	E-Line	25	2.5	6	450

Note 1: When mounted on an industry standard 15 x15mm ceramic substrate. For an FR4 assembly, and a board of 1" x1", the FMMT618/718 series of "SuperSOT" transistors can achieve a Pd of 700mW.

Note2: $h_{FE}(mb)$ - the value of the mid band current gain.

Table 1
Zetex Bipolar Transistors for MOSFET Gate Driver Applications.

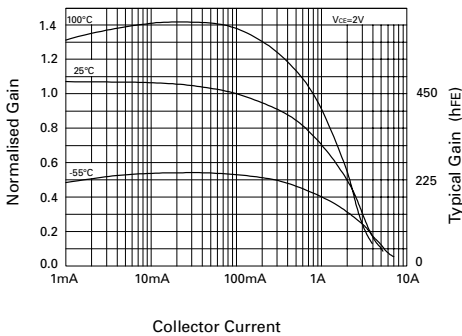

Figure 7
h_{FE} Profile for the FMMT718.

showing the response (albeit somewhat contrived for the purpose of illustration) of the g-s voltage and the resulting charge and discharge current provided by the complimentary emitter follower shown in figure 2. Figure 8 is for a 500V 3Ω part, while Figure 9 is for a 500V 900mΩ part. The lower trace in both cases being the control pulse to the driver stage, and the load is 2.4A resistive from a 350V supply. A peak pulse current of 400mA, and 1.6A being apparent respectively. A Tektronix current probe was used to measure the gate current in a 0.75" loop.

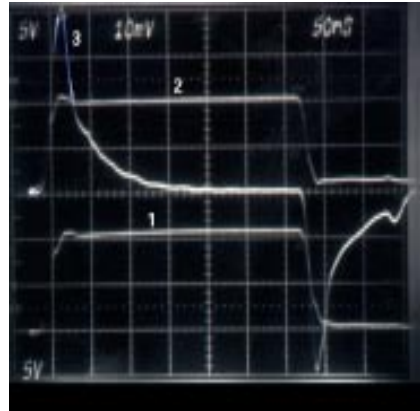

Figure 8
High Current Gate Driver with 500V 3Ω MOSFET; 2.4A Load.
1. Logic signal 5V/div., 2. G-S Voltage 5V/div., 3. G-S Current 100mA/div.
Timebase at 50ns/div.

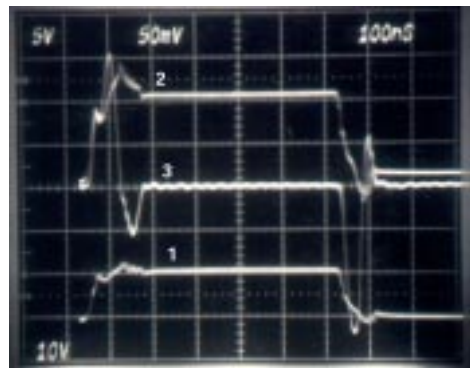

Figure 9
High Current Gate Driver with 500V 900mΩ MOSFET; 2.4A Load.
1. Logic Signal 10V/div., 2. G-S Voltage 5V/div., 3. G-S Current 500mA/div.
Timebase at 100ns/div.