

DATA SHEET

TDA8351 DC-coupled vertical deflection circuit

Preliminary specification
Supersedes data of June 1992
File under Integrated Circuits, IC02

January 1995

Philips Semiconductors



PHILIPS

DC-coupled vertical deflection circuit

TDA8351

FEATURES

- Few external components
- Highly efficient fully DC-coupled vertical output bridge circuit
- Vertical flyback switch
- Guard circuit
- Protection against:
 - short-circuit of the output pins (7 and 4)
 - short-circuit of the output pins to V_P
- Temperature (thermal) protection
- High EMC immunity because of common mode inputs
- A guard signal in zoom mode.

GENERAL DESCRIPTION

The TDA8351 is a power circuit for use in 90° and 110° colour deflection systems for field frequencies of 50 to 120 Hz. The circuit provides a DC driven vertical deflection output circuit, operating as a highly efficient class G system.

QUICK REFERENCE DATA

SYMBOL	PARAMETER	CONDITIONS	MIN.	TYP.	MAX.	UNIT
DC supply						
V_P	supply voltage		9	–	25	V
I_q	quiescent supply current		–	30	–	mA
Vertical circuit						
$I_{O(p-p)}$	output current (peak-to-peak value)		–	–	3	A
$I_{diff(p-p)}$	differential input current (peak-to-peak value)		–	600	–	μ A
$V_{diff(p-p)}$	differential input voltage (peak-to-peak value)		–	1.5	1.8	V
Flyback switch						
I_M	peak output current		–	–	± 1.5	A
V_{FB}	flyback supply voltage		–	–	50	V
		note 1	–	–	60	V
Thermal data (in accordance with IEC 747-1)						
T_{stg}	storage temperature		–55	–	+150	$^{\circ}$ C
T_{amb}	operating ambient temperature		–25	–	+75	$^{\circ}$ C
T_{vj}	virtual junction temperature		–	–	150	$^{\circ}$ C

Note

1. A flyback supply voltage of >50 V up to 60 V is allowed in application. A 220 nF capacitor in series with a 22 Ω resistor (dependent on I_O and the inductance of the coil) has to be connected between pin 7 and ground. The decoupling capacitor of V_{FB} has to be connected between pin 6 and pin 3. This supply voltage line must have a resistance of 33 Ω (see application circuit Fig.6).

DC-coupled vertical deflection circuit

TDA8351

ORDERING INFORMATION

TYPE NUMBER	PACKAGE		
	NAME	DESCRIPTION	VERSION
TDA8351	SIL9P	plastic single-in-line power package; 9 leads	SOT131-2

BLOCK DIAGRAM

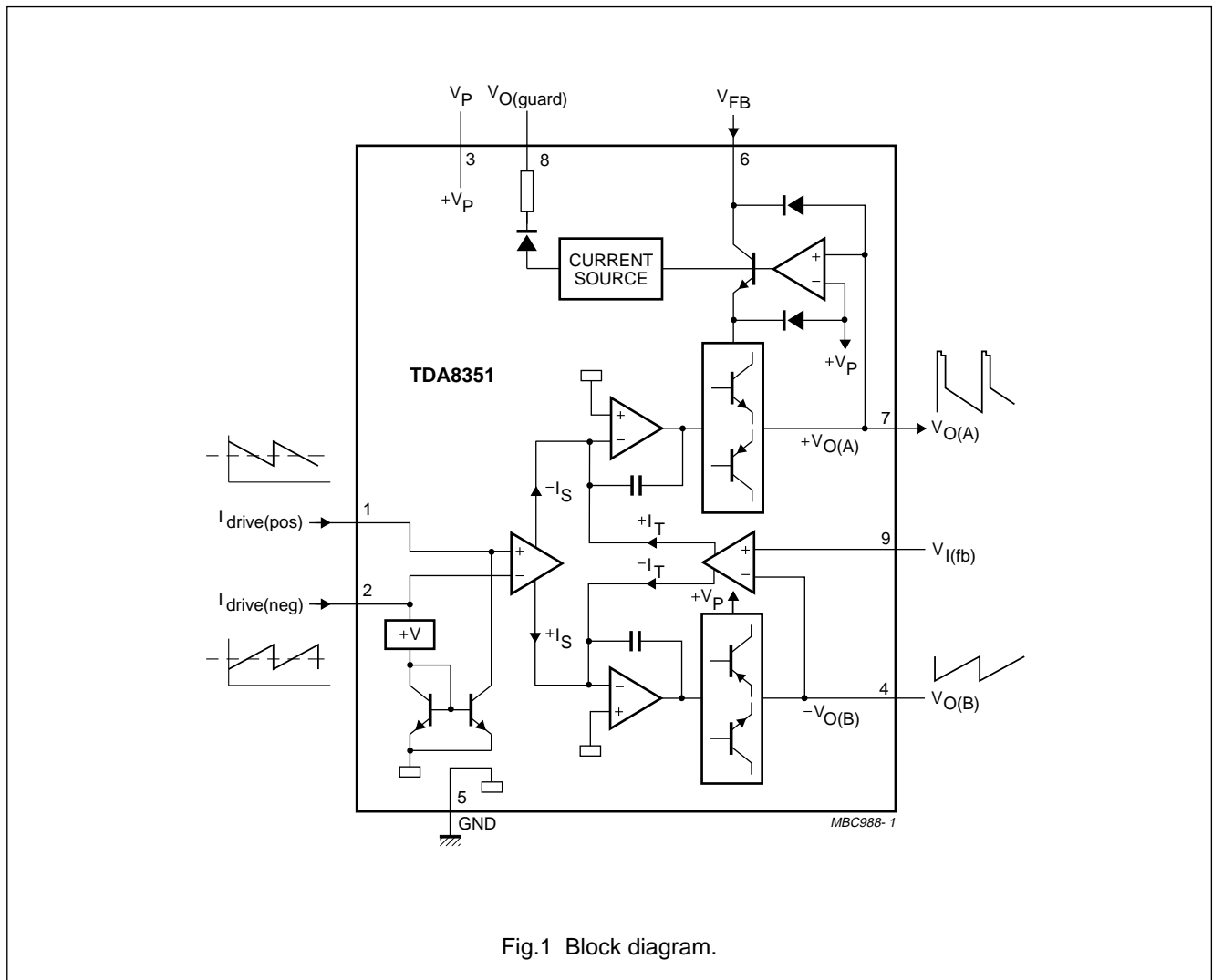

Fig.1 Block diagram.

DC-coupled vertical deflection circuit

TDA8351

PINNING

SYMBOL	PIN	DESCRIPTION
$I_{drive(pos)}$	1	input power-stage (positive); includes $I_{I(s_b)}$ signal bias
$I_{drive(neg)}$	2	input power-stage (negative); includes $I_{I(s_b)}$ signal bias
V_P	3	operating supply voltage
$V_{O(B)}$	4	output voltage B
GND	5	ground
V_{FB}	6	input flyback supply voltage
$V_{O(A)}$	7	output voltage A
$V_{O(guard)}$	8	guard output voltage
$V_{I(fb)}$	9	input feedback voltage

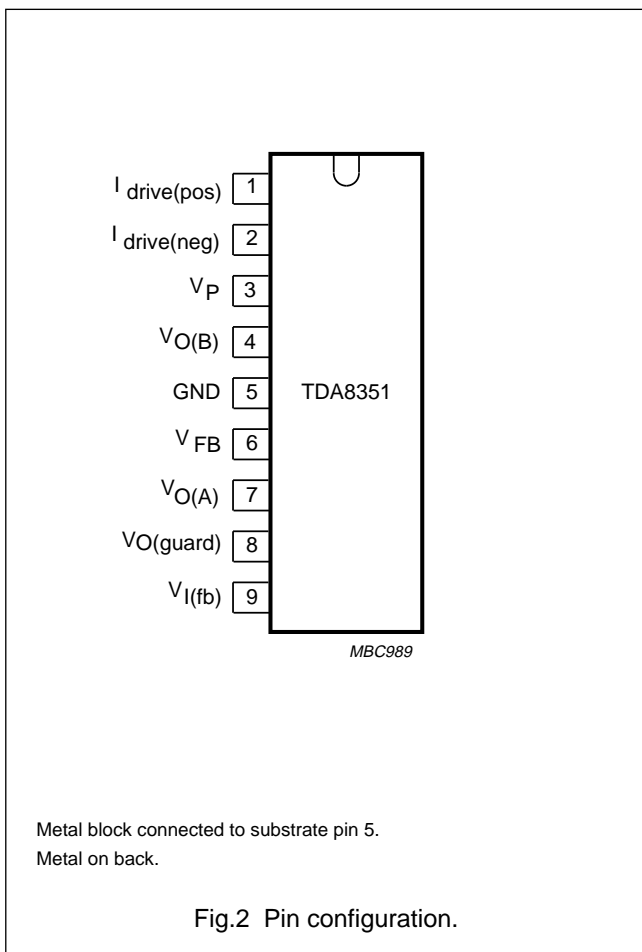

FUNCTIONAL DESCRIPTION

The vertical driver circuit is a bridge configuration. The deflection coil is connected between the output amplifiers, which are driven in phase opposition. An external resistor (R_M) connected in series with the deflection coil provides internal feedback information. The differential input circuit is voltage driven. The input circuit has been adapted to enable it to be used with the TDA9150, TDA9151B, TDA9160A, TDA9162, TDA8366 and TDA8376 which deliver symmetrical current signals. An external resistor (R_{CON}) connected between the differential input determines the output current through the deflection coil. The relationship between the differential input current and the output current is defined by: $I_{diff} \times R_{CON} = I_{coil} \times R_M$. The output current is adjustable from 0.5 A (p-p) to 3 A (p-p) by varying R_M . The maximum input differential voltage is 1.8 V. In the application it is recommended that $V_{diff} = 1.5$ V (typ). This is recommended because of the spread of input current and the spread in the value of R_{CON} .

The flyback voltage is determined by an additional supply voltage V_{FB} . The principle of operating with two supply voltages (class G) makes it possible to fix the supply voltage V_P optimum for the scan voltage and the second supply voltage V_{FB} optimum for the flyback voltage. Using this method, very high efficiency is achieved.

The supply voltage V_{FB} is almost totally available as flyback voltage across the coil, this being possible due to the absence of a decoupling capacitor (not necessary, due to the bridge configuration). The output circuit is fully protected against the following:

- thermal protection
- short-circuit protection of the output pins (pins 4 and 7)
- short-circuit of the output pins to V_P .

A guard circuit $V_{O(guard)}$ is provided. The guard circuit is activated at the following conditions:

- during flyback
- during short-circuit of the coil and during short-circuit of the output pins (pins 4 and 7) to V_P or ground
- during open loop
- when the thermal protection is activated.

This signal can be used for blanking the picture tube screen.

DC-coupled vertical deflection circuit

TDA8351

LIMITING VALUES

In accordance with the Absolute Maximum Rating System (IEC 134).

SYMBOL	PARAMETER	CONDITIONS	MIN.	MAX.	UNIT
DC supply					
V_P	supply voltage	non-operating	–	40	V
			–	25	V
V_{FB}	flyback supply voltage		–	50	V
		note 1	–	60	V
Vertical circuit					
$I_{O(p-p)}$	output current (peak-to-peak value)	note 2	–	3	A
$V_{O(A)}$	output voltage (pin 7)		–	52	V
		note 1	–	62	V
Flyback switch					
I_M	peak output current		–	± 1.5	A
Thermal data (in accordance with IEC 747-1)					
T_{stg}	storage temperature		–55	+150	°C
T_{amb}	operating ambient temperature		–25	+75	°C
T_{vj}	virtual junction temperature		–	150	°C
$R_{th\ vj-c}$	resistance v_j -case		–	4	K/W
$R_{th\ vj-a}$	resistance v_j -ambient in free air		–	40	K/W
t_{sc}	short-circuiting time	note 3	–	1	hr

Notes

1. A flyback supply voltage of >50 V up to 60 V is allowed in application. A 220 nF capacitor in series with a 22 Ω resistor (dependent on I_O and the inductance of the coil) has to be connected between pin 7 and ground. The decoupling capacitor of V_{FB} has to be connected between pin 6 and pin 3. This supply voltage line must have a resistance of 33 Ω (see application circuit Fig.6).
2. I_O maximum determined by current protection.
3. Up to $V_P = 18$ V.

DC-coupled vertical deflection circuit

TDA8351

CHARACTERISTICS

$V_P = 17.5$ V; $T_{amb} = 25$ °C; $V_{FB} = 45$ V; $f_i = 50$ Hz; $I_{I(sb)} = 400$ μ A; measured in test circuit of Fig.3; unless otherwise specified.

SYMBOL	PARAMETER	CONDITIONS	MIN.	TYP.	MAX.	UNIT
DC supply						
V_P	operating supply voltage		9.0	–	25	V
V_{FB}	flyback supply voltage		V_P	–	50	V
		note 1	V_P	–	60	V
I_P	supply current	no signal; no load	–	30	55	mA
Vertical circuit						
V_O	output voltage swing (scan)	$I_{diff} = 0.6$ mA (p-p); $V_{diff} = 1.8$ V (p-p); $I_O = 3$ A (p-p)	19.8	–	–	V
LE	linearity error	$I_O = 3$ A (p-p); note 2	–	1	2	%
		$I_O = 50$ mA (p-p); note 2	–	1	2	%
V_O	output voltage swing (flyback) $V_{O(A)} - V_{O(B)}$	$I_{diff} = 0.3$ mA; $I_O = 1.5$ A (M)	–	39	–	V
V_{DF}	forward voltage of the internal efficiency diode ($V_{O(A)} - V_{FB}$)	$I_O = -1.5$ A (M); $I_{diff} = 0.3$ mA	–	–	1.5	V
$ I_{osl} $	output offset current	$I_{diff} = 0$; $I_{I(sb)} = 50$ to 500 μ A	–	–	30	mA
$ V_{osl} $	offset voltage at the input of the feedback amplifier ($V_{I(fb)} - V_{O(B)}$)	$I_{diff} = 0$; $I_{I(sb)} = 50$ to 500 μ A	–	–	18	mV
ΔV_{osT}	output offset voltage as a function of temperature	$I_{diff} = 0$	–	–	72	μ V/K
$V_{O(A)}$	DC output voltage	$I_{diff} = 0$; note 3	–	8.0	–	V
G_{vo}	open-loop voltage gain (V_{7-4}/V_{1-2})	notes 4 and 5	–	80	–	dB
	open loop voltage gain (V_{7-4}/V_{9-4} ; $V_{1-2} = 0$)	note 4	–	80	–	dB
V_R	voltage ratio V_{1-2}/V_{9-4}		–	0	–	dB
f_{res}	frequency response (–3 dB)	open loop; note 6	–	40	–	Hz
G_I	current gain (I_O/I_{diff})		–	5000	–	
ΔG_{cT}	current gain drift as a function of temperature		–	–	10^{-4}	K
$I_{I(sb)}$	signal bias current		50	400	500	μ A
I_{FB}	flyback supply current	during scan	–	–	100	μ A
PSRR	power supply ripple rejection	note 7	–	80	–	dB
$V_{I(DC)}$	DC input voltage		–	2.7	–	V
$V_{I(CM)}$	common mode input voltage	$I_{I(sb)} = 0$	0	–	1.6	V
I_{bias}	input bias current	$I_{I(sb)} = 0$	–	0.1	0.5	μ A
$I_{O(CM)}$	common mode output current	$\Delta I_{I(sb)} = 300$ μ A (p-p); $f_i = 50$ Hz; $I_{diff} = 0$	–	0.2	–	mA

DC-coupled vertical deflection circuit

TDA8351

SYMBOL	PARAMETER	CONDITIONS	MIN.	TYP.	MAX.	UNIT
Guard circuit						
I _O	output current	not active; V _{O(guard)} = 0 V	–	–	50	μA
		active; V _{O(guard)} = 4.5 V	1	–	2.5	mA
V _{O(guard)}	output voltage on pin 8	I _O = 100 μA	–	–	5.5	V
	allowable voltage on pin 8	maximum leakage current = 10 μA;	–	–	40	V

Notes

- A flyback supply voltage of >50 V up to 60 V is allowed in application. A 220 nF capacitor in series with a 22 Ω resistor (dependent on I_O and the inductance of the coil) has to be connected between pin 7 and ground. The decoupling capacitor of V_{FB} has to be connected between pin 6 and pin 3. This supply voltage line must have a resistance of 33 Ω (see application circuit Fig.6).
- The linearity error is measured without S-correction and based on the same measurement principle as performed on the screen. The measuring method is as follows:
Divide the output signal I₄ - I₇ (V_{RM}) into 22 equal parts ranging from 1 to 22 inclusive. Measure the value of two succeeding parts called one block starting with part 2 and 3 (block 1) and ending with part 20 and 21 (block 10). Thus part 1 and 22 are unused. The equations for linearity error for adjacent blocks (LEAB) and not adjacent blocks (NAB) are given below

$$\text{LEAB} = \frac{a_k - a_{(k+1)}}{a_{\text{avg}}}; \quad \text{NAB} = \frac{a_{\text{max}} - a_{\text{min}}}{a_{\text{avg}}}$$
- Referenced to V_p.
- V values within formulae, relate to voltages at or between relative pin numbers, i.e. V₇₋₄/V₁₋₂ = voltage value across pins 7 and 4 divided by voltage value across pins 1 and 2.
- V₉₋₄ AC short-circuited.
- Frequency response V₇₋₄/V₉₋₄ is equal to frequency response V₇₋₄/V₁₋₂.
- At V_(ripple) = 500 mV eff; measured across R_M; f_i = 50 Hz.

DC-coupled vertical deflection circuit

TDA8351

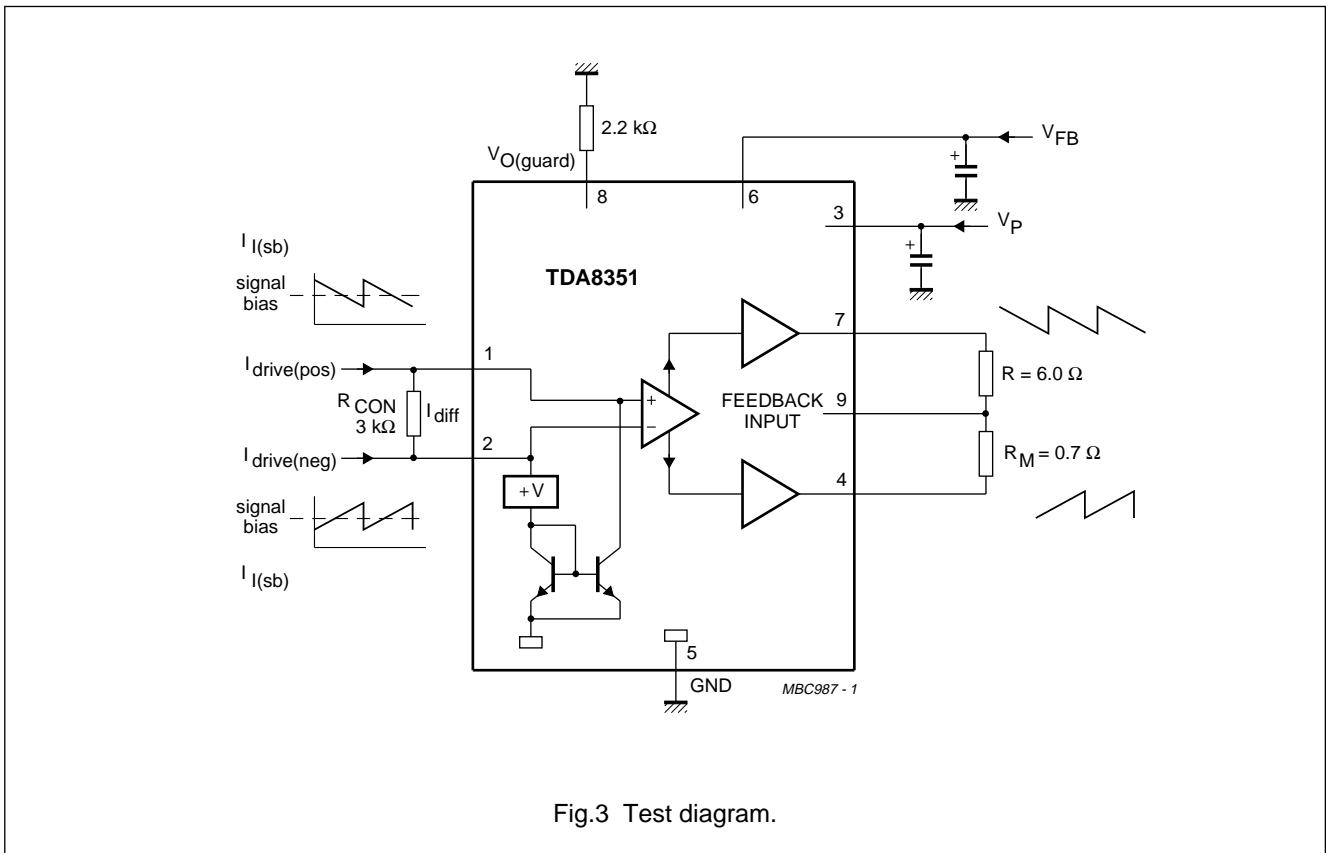

Fig.3 Test diagram.

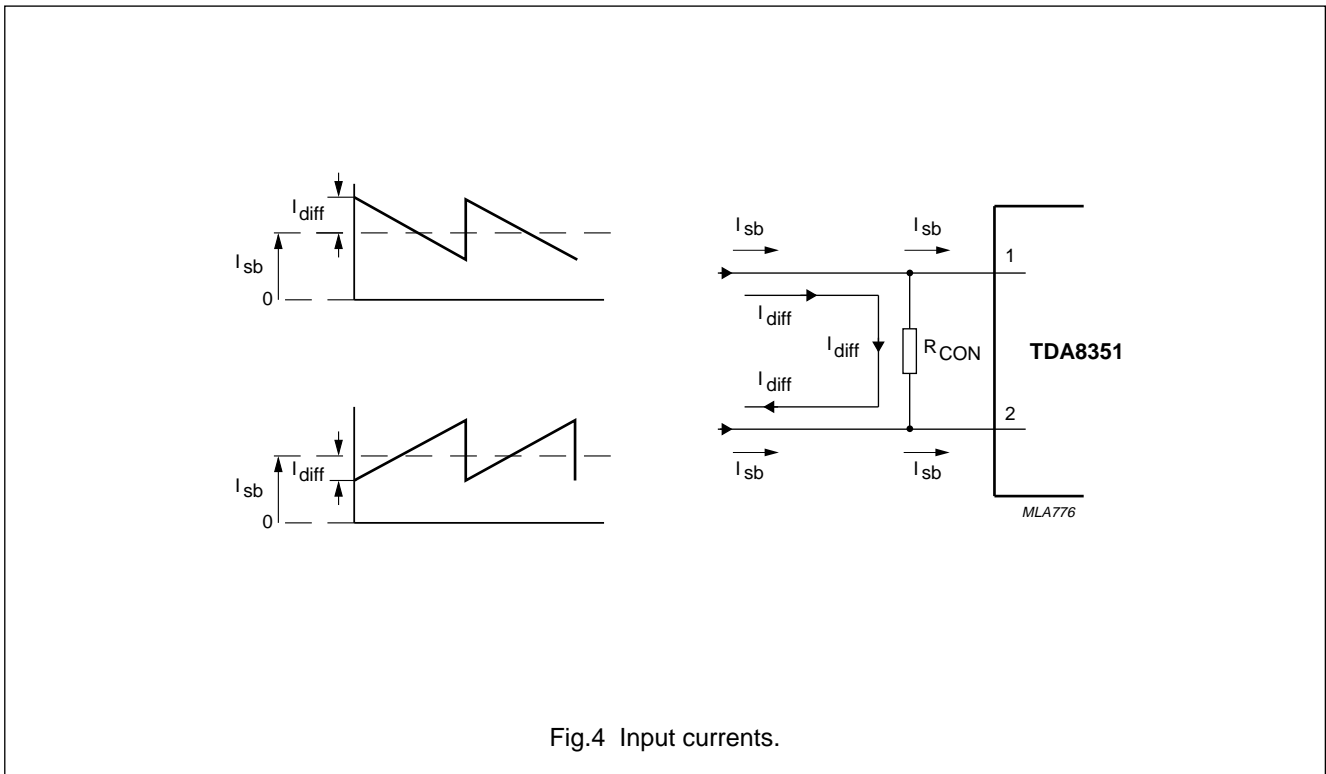
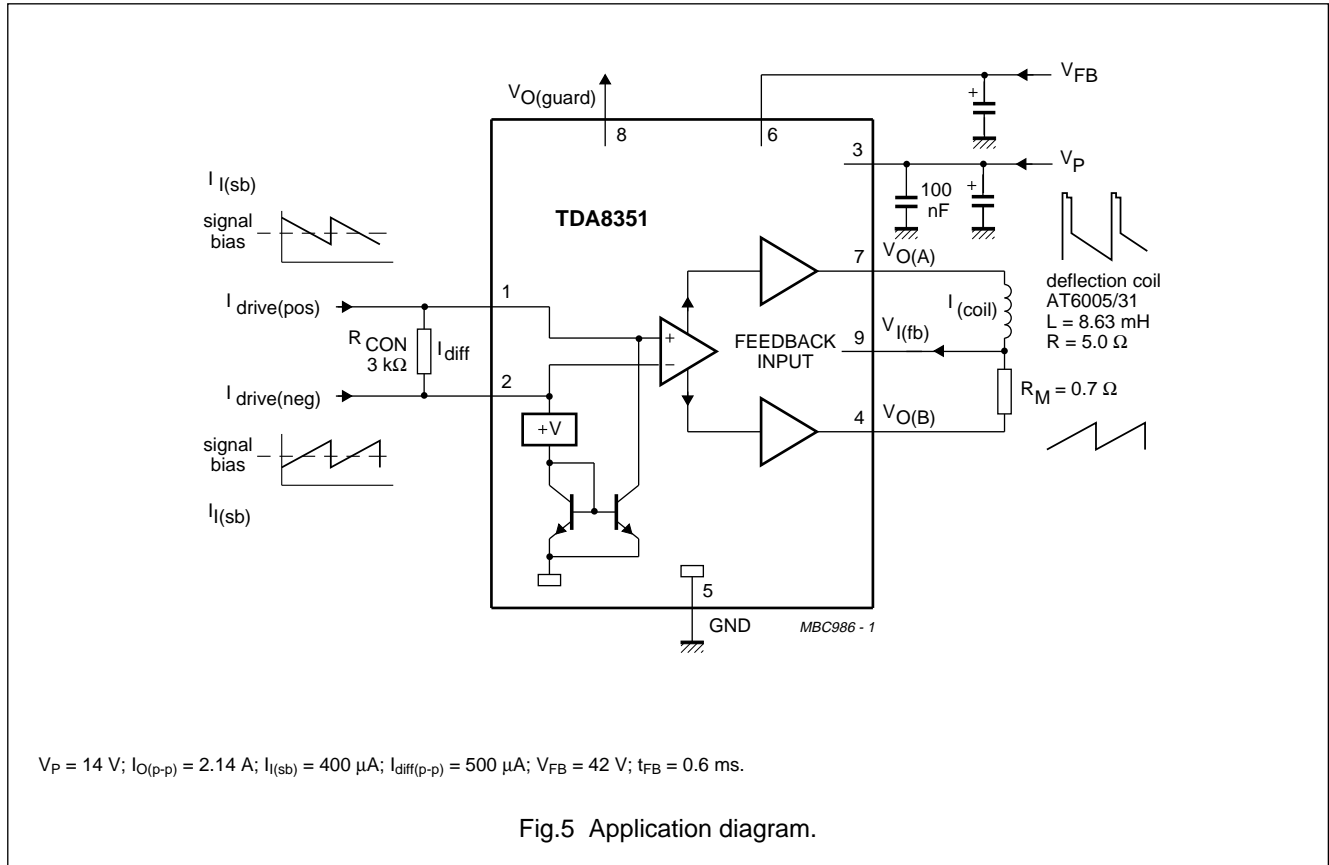

Fig.4 Input currents.

DC-coupled vertical deflection circuit

TDA8351

APPLICATION INFORMATION



DC-coupled vertical deflection circuit

TDA8351

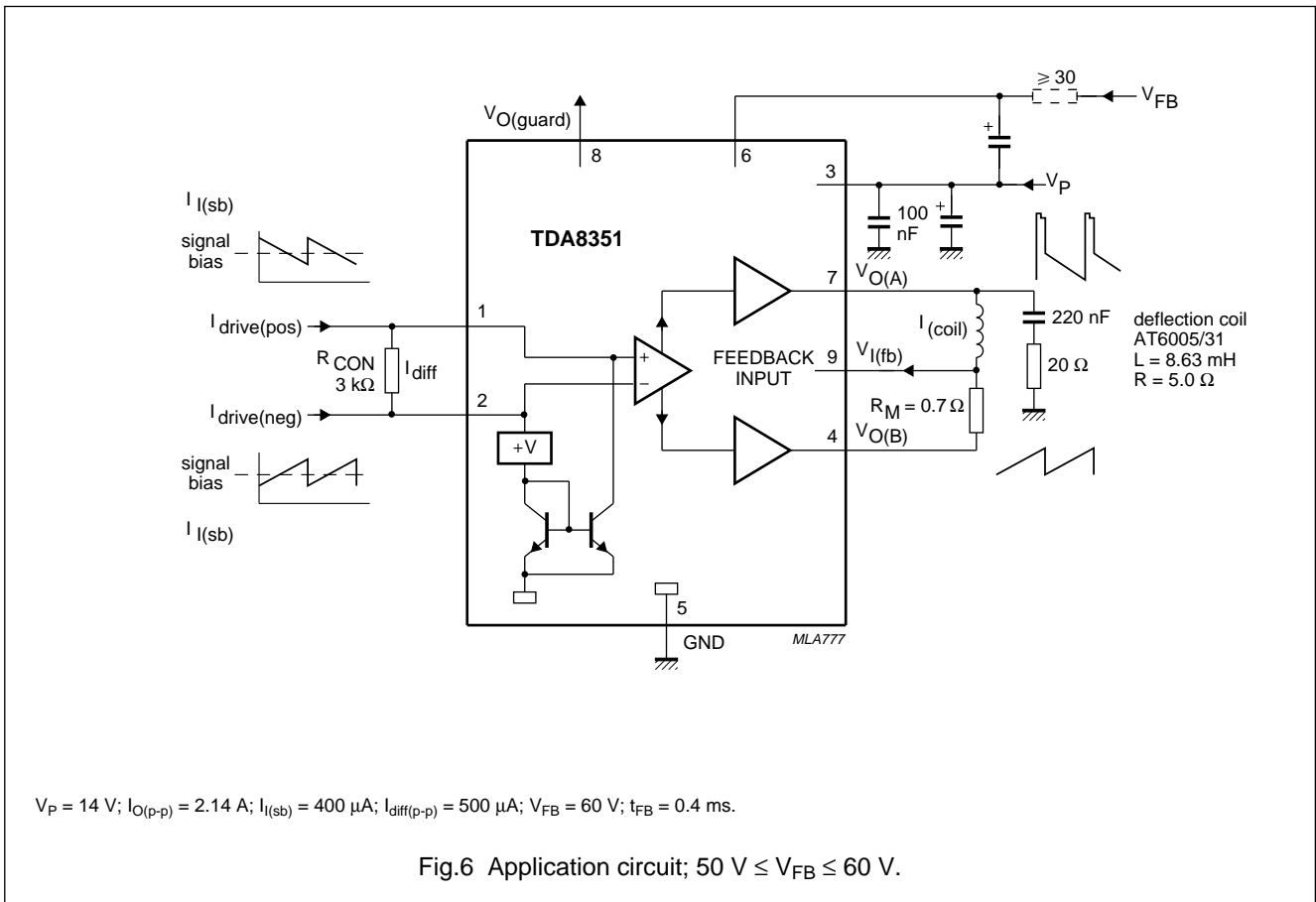

DC-coupled vertical deflection circuit

TDA8351

PACKAGE OUTLINE

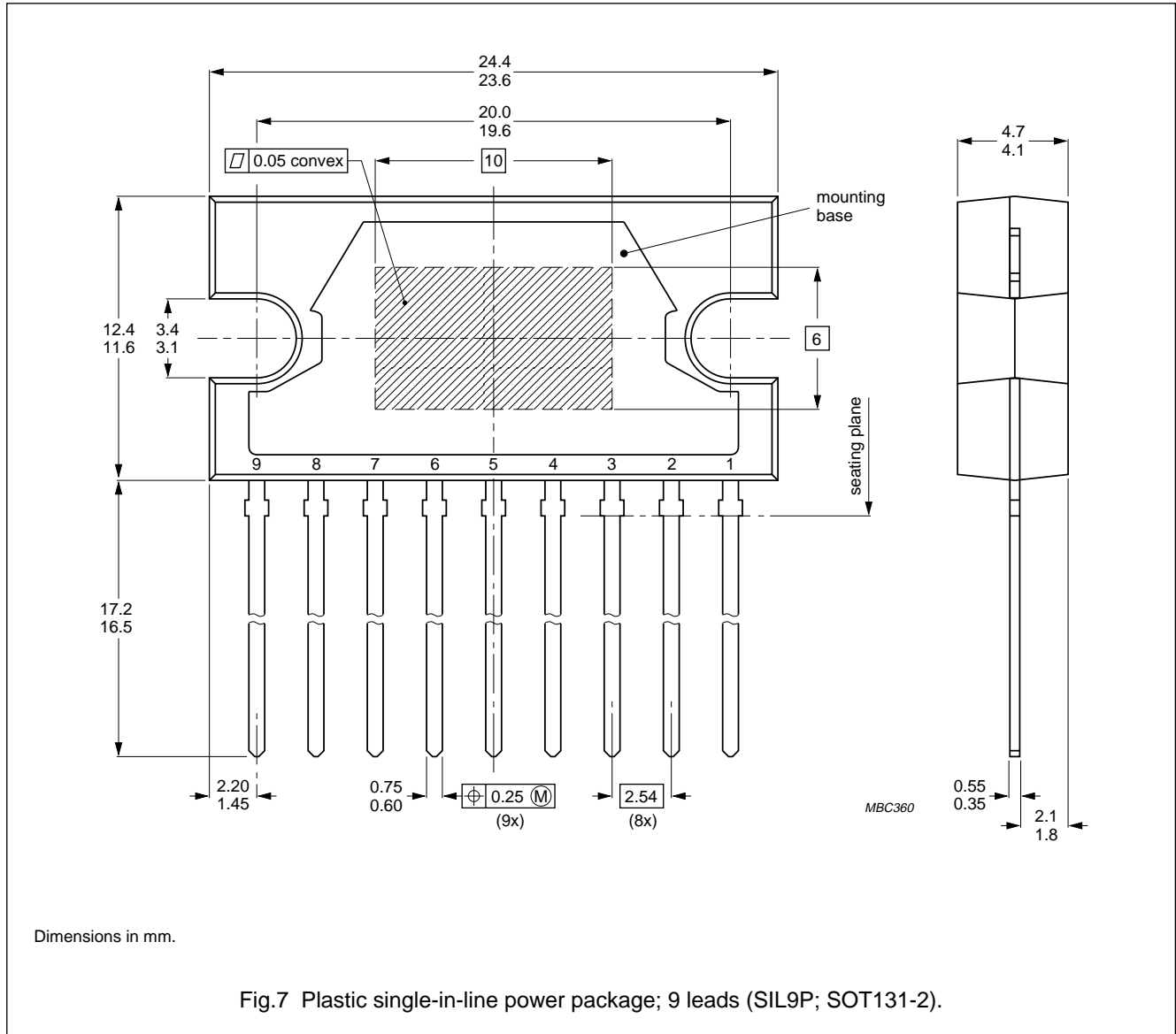

DC-coupled vertical deflection circuit

TDA8351

SOLDERING**Plastic single in-line packages**

BY DIP OR WAVE

The maximum permissible temperature of the solder is 260 °C; this temperature must not be in contact with the joint for more than 5 s. The total contact time of successive solder waves must not exceed 5 s.

The device may be mounted up to the seating plane, but the temperature of the plastic body must not exceed the

specified storage maximum. If the printed-circuit board has been pre-heated, forced cooling may be necessary immediately after soldering to keep the temperature within the permissible limit.

REPAIRING SOLDERED JOINTS

Apply the soldering iron below the seating plane (or not more than 2 mm above it. If its temperature is below 300 °C, it must not be in contact for more than 10 s; if between 300 and 400 °C, for not more than 5 s.

DEFINITIONS

Data sheet status	
Objective specification	This data sheet contains target or goal specifications for product development.
Preliminary specification	This data sheet contains preliminary data; supplementary data may be published later.
Product specification	This data sheet contains final product specifications.
Limiting values	
Limiting values given are in accordance with the Absolute Maximum Rating System (IEC 134). Stress above one or more of the limiting values may cause permanent damage to the device. These are stress ratings only and operation of the device at these or at any other conditions above those given in the Characteristics sections of this specification is not implied. Exposure to limiting values for extended periods may affect device reliability.	
Application information	
Where application information is given, it is advisory and does not form part of the specification.	

LIFE SUPPORT APPLICATIONS

These products are not designed for use in life support appliances, devices, or systems where malfunction of these products can reasonably be expected to result in personal injury. Philips customers using or selling these products for use in such applications do so at their own risk and agree to fully indemnify Philips for any damages resulting from such improper use or sale.

DC-coupled vertical deflection circuit

TDA8351

NOTES

DC-coupled vertical deflection circuit

TDA8351

NOTES

DC-coupled vertical deflection circuit

TDA8351

NOTES

Philips Semiconductors – a worldwide company

Argentina: IEROD, Av. Juramento 1992 - 14.b, (1428)
BUENOS AIRES, Tel. (541)786 7633, Fax. (541)786 9367

Australia: 34 Waterloo Road, NORTH RYDE, NSW 2113,
Tel. (02)805 4455, Fax. (02)805 4466

Austria: Triester Str. 64, A-1101 WIEN, P.O. Box 213,
Tel. (01)60 101-1236, Fax. (01)60 101-1211

Belgium: Postbus 90050, 5600 PB EINDHOVEN, The Netherlands,
Tel. (31)40 783 749, Fax. (31)40 788 399

Brazil: Rua do Rocio 220 - 5th floor, Suite 51,
CEP: 04552-903-SÃO PAULO-SP, Brazil.
P.O. Box 7383 (01064-970).

Tel. (011)821-2333, Fax. (011)829-1849

Canada: PHILIPS SEMICONDUCTORS/COMPONENTS:
Tel. (800) 234-7381, Fax. (708) 296-8556

Chile: Av. Santa Maria 0760, SANTIAGO,
Tel. (02)773 816, Fax. (02)777 6730

Colombia: IPRELENZO LTDA, Carrera 21 No. 56-17,
77621 BOGOTA, Tel. (571)249 7624/(571)217 4609,
Fax. (571)217 4549

Denmark: Prags Boulevard 80, PB 1919, DK-2300 COPENHAGEN S,
Tel. (032)88 2636, Fax. (031)57 1949

Finland: Sinikalliontie 3, FIN-02630 ESPOO,
Tel. (9)0-50261, Fax. (9)0-520971

France: 4 Rue du Port-aux-Vins, BP317,
92156 SURESNES Cedex,
Tel. (01)4099 6161, Fax. (01)4099 6427

Germany: P.O. Box 10 63 23, 20043 HAMBURG,
Tel. (040)3296-0, Fax. (040)3296 213.

Greece: No. 15, 25th March Street, GR 17778 TAVROS,
Tel. (01)4894 339/4894 911, Fax. (01)4814 240

Hong Kong: PHILIPS HONG KONG Ltd., 6/F Philips Ind. Bldg.,
24-28 Kung Yip St., KWAI CHUNG, N.T.,
Tel. (852)424 5121, Fax. (852)428 6729

India: Philips INDIA Ltd, Shivsagar Estate, A Block,
Dr. Annie Besant Rd. Worli, Bombay 400 018
Tel. (022)4938 541, Fax. (022)4938 722

Indonesia: Philips House, Jalan H.R. Rasuna Said Kav. 3-4,
P.O. Box 4252, JAKARTA 12950,
Tel. (021)5201 122, Fax. (021)5205 189

Ireland: Newstead, Clonskeagh, DUBLIN 14,
Tel. (01)640 000, Fax. (01)640 200

Italy: PHILIPS SEMICONDUCTORS S.r.l.,
Piazza IV Novembre 3, 20124 MILANO,
Tel. (0039)2 6752 2531, Fax. (0039)2 6752 2557

Japan: Philips Bldg 13-37, Kohnan2-chome, Minato-ku, TOKYO 108,
Tel. (03)3740 5028, Fax. (03)3740 0580

Korea: (Republic of) Philips House, 260-199 Itaewon-dong,
Yongsan-ku, SEOUL, Tel. (02)794-5011, Fax. (02)798-8022

Malaysia: No. 76 Jalan Universiti, 46200 PETALING JAYA,
SELANGOR, Tel. (03)750 5214, Fax. (03)757 4880

Mexico: 5900 Gateway East, Suite 200, EL PASO, TX 79905,
Tel. 9-5(800)234-7381, Fax. (708)296-8556

Netherlands: Postbus 90050, 5600 PB EINDHOVEN, Bldg. VB
Tel. (040)783749, Fax. (040)788399

New Zealand: 2 Wagener Place, C.P.O. Box 1041, AUCKLAND,
Tel. (09)849-4160, Fax. (09)849-7811

Norway: Box 1, Manglerud 0612, OSLO,
Tel. (022)74 8000, Fax. (022)74 8341

Pakistan: Philips Electrical Industries of Pakistan Ltd.,
Exchange Bldg. ST-2/A, Block 9, KDA Scheme 5, Clifton,
KARACHI 75600, Tel. (021)587 4641-49,
Fax. (021)577035/5874546.

Philippines: PHILIPS SEMICONDUCTORS PHILIPPINES Inc,
106 Valero St. Salcedo Village, P.O. Box 2108 MCC, MAKATI,
Metro MANILA, Tel. (02)810 0161, Fax. (02)817 3474

Portugal: PHILIPS PORTUGUESA, S.A.,
Rua dr. António Loureiro Borges 5, Arquiparque - Miraflores,
Apartado 300, 2795 LINDA-A-VELHA,
Tel. (01)4163160/4163333, Fax. (01)4163174/4163366.

Singapore: Lorong 1, Toa Payoh, SINGAPORE 1231,
Tel. (65)350 2000, Fax. (65)251 6500

South Africa: S.A. PHILIPS Pty Ltd.,
195-215 Main Road Martindale, 2092 JOHANNESBURG,
P.O. Box 7430 Johannesburg 2000,
Tel. (011)470-5911, Fax. (011)470-5494.

Spain: Balmes 22, 08007 BARCELONA,
Tel. (03)301 6312, Fax. (03)301 42 43

Sweden: Kottbygatan 7, Akalla. S-164 85 STOCKHOLM,
Tel. (0)8-632 2000, Fax. (0)8-632 2745

Switzerland: Allmendstrasse 140, CH-8027 ZÜRICH,
Tel. (01)488 2211, Fax. (01)481 77 30

Taiwan: PHILIPS TAIWAN Ltd., 23-30F, 66, Chung Hsiao West
Road, Sec. 1. Taipei, Taiwan ROC, P.O. Box 22978,
TAIPEI 100, Tel. (02)388 7666, Fax. (02)382 4382.

Thailand: PHILIPS ELECTRONICS (THAILAND) Ltd.,
209/2 Sanpavuth-Bangna Road Prakanong,
Bangkok 10260, THAILAND,
Tel. (662)398-0141, Fax. (662)398-3319.

Turkey: Talatpasa Cad. No. 5, 80640 GÜLTEPE/ISTANBUL,
Tel. (0212)279 2770, Fax. (0212)269 3094

United Kingdom: Philips Semiconductors LTD.,
276 Bath Road, Hayes, MIDDLESEX UB3 5BX,
Tel. (081)730-5000, Fax. (081)754-8421

United States: 811 East Arques Avenue, SUNNYVALE,
CA 94088-3409, Tel. (800)234-7381, Fax. (708)296-8556

Uruguay: Coronel Mora 433, MONTEVIDEO,
Tel. (02)70-4044, Fax. (02)92 0601

For all other countries apply to: Philips Semiconductors,
International Marketing and Sales, Building BE-p,
P.O. Box 218, 5600 MD, EINDHOVEN, The Netherlands,
Telex 35000 phtcnl, Fax. +31-40-724825

SCD36 © Philips Electronics N.V. 1994

All rights are reserved. Reproduction in whole or in part is prohibited without the prior written consent of the copyright owner.

The information presented in this document does not form part of any quotation or contract, is believed to be accurate and reliable and may be changed without notice. No liability will be accepted by the publisher for any consequence of its use. Publication thereof does not convey nor imply any license under patent- or other industrial or intellectual property rights.

Printed in The Netherlands

533061/1500/02/pp16
Document order number:

Date of release: January 1995
9397 745 10011

Philips Semiconductors



PHILIPS