

FEATURES

- COMPLETE ENCODER/TRANSMITTER
- 1 - 2 SWITCH 'KEYFOB' HOUSING
- 1 - 4 SWITCH 'ENCODER' HOUSING
- "CODE HOPPING" PROTOCOL FOR HIGH SECURITY.
- LOW POWER CONSUMPTION (>1 MILLION TRANSMISSIONS FROM A PP3 BATTERY).
- SUPPLIED AS COMPLETE ENCLOSURE, OR AS PCB MODULE WITH INTEGRAL ANTENNA.
- WIDE SUPPLY VOLTAGE: 9 - 12 VOLTS.
- DIRECTLY COMPATIBLE WITH RS FM DECODERS



DESCRIPTION

The FM Encoder series Transmitter/Encoders can be used to transmit R.F. Data to the RS range of FM Decoders. (RS Stock Code 226-3483). As a system it enables the user to "bolt on" a remote control system to an application with a simple interface and minimal configuration set-up.

When paired with one of the Receiver/Decoder Boards, a complete high security "code hopping" remote control system is achieved, with comprehensive interfacing capabilities.

Benefits of FM transmission include high reliability, long range, and low power, thus lending itself to many applications that cannot be implemented with an AM system. (A range of up to 50m in direct line of sight may be achieved).

It is supplied as either a PCB module or as a complete enclosed, hand held, remote control. As a complete remote control, the case may be supplied as a 1 or 2 switch pocket keyfob or a 1-4 switch hand held encoder. The keyfob is supplied complete with a Type GP27 battery. The hand held encoder is supplied with PP3 type battery.

The decoder is capable of 'learning' the transmitter/Encoder signature code, and switch number.

The decoder allocates the transmitter/encoder switch against the chosen output. The decoder has a maximum memory capacity of learning up to eight switches. These may be from a single or many different encoders and be allocated to a single output on the decoder or a combination of all the outputs

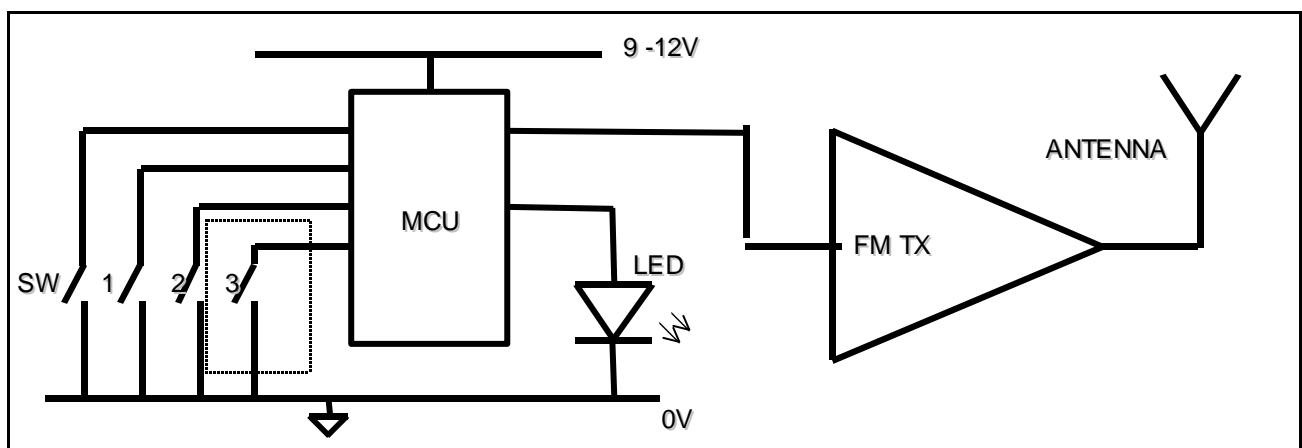

BLOCK DIAGRAM



FM RADIO ENCODERS RS VERSION.

OPERATION

The transmitter transmits the code for as long as any push-button switch is depressed. Operation of the transmitter buttons will cause either a momentary action or a latching action at the decoder, depending on the configuration of the decoder or expander board.

MECHANICAL DETAILS

The overall dimensions of the case are

Pocket Keyfob :	Length : 58mm, Width : 36mm, Depth : 15mm	Battery Type : GP27A
Hand Held Encoder :	Length : 109mm, Width : 64mm, Depth : 24mm	Battery Type : PP3

ANTENNA

The antenna has been included in the PCB tracking. This should provide adequate range for most applications. Note that due to the difference in physical size of the 'Pocket Keyfob' and the 'Hand Held Enclosure' The range achieved from the 'Hand held Enclosure' will be substantially greater than the 'Pocket Keyfob'.

The range achieved from the system is dependent on the position of the antenna. If a custom antenna is required, for optimum range, follow these general rules;

- The space around the antenna is as important as the antenna itself.
- The optimum position is to locate the antenna so that it protrudes directly out the top of the enclosure.
- If this is not possible due to other design constraints, try to keep the antenna away from other metal in the system such as transformers, batteries and PCB tracks, especially ground planes.

In particular, the 'HOT' end of the antenna should be kept as far away as possible from these.

LICENCE EXEMPTION

This range of Radio transmitters is approved by the Department of Trade & Industry (D.T.I. Specification MPT1340) in the U.K., and therefore the user requires no radio operating licence in the U.K.

Please note however the following requirements to comply with MPT1340;

1. All transmitters shall use integral antennas only. Receivers may use an external or integral antenna. An integral antenna is defined as one which is designed to be connected permanently to the transmitter or receiver without the use of an external feeder.

ABSOLUTE MAXIMUM RATINGS

Supply Voltage (Vcc to GND).....-0.3 to +13 Volts.
 Storage Temperature.....-10 to +70° Celcius.
 Operating Temperature.....0 to +55° Celcius.

TECHNICAL SPECIFICATION

Ambient temperature = 20° Celcius. Supply Voltage Vcc = 9 Volts.

ELECTRICAL CHARACTERISTICS	MIN	TYPICAL	MAX	DIMENSION
Supply Voltage	8.5	9	12	V
Supply Current				
Quiescent		0		mA
Active		18		mA
Operating Frequency	-	418.0	-	MHz
Overall Frequency Accuracy	-100	0	+100	KHz

TRANSMITTER / ENCODER PART NUMBERING

'Pocket Keyfob' 418MHz	
Description	RS Stock Code
1 SW Keyfob	226-3382
2 SW Keyfob	226-3427

'Hand Held Enclosure' 418MHz	
Description	RS Stock Code
ENCODER 1 SW IN CASE	226-3433
ENCODER 2 SW IN CASE	226-3461
ENCODER 3 SW IN CASE	226-3455
ENCODER 4 SW IN CASE	226-3449

433MHz	
Description	RS Stock Code
1 SW Keyfob	250-0518
2 SW Keyfob	250-0524

433MHz	
Description	RS Stock Code
ENCODER 1 SW IN CASE	250-0546
ENCODER 2 SW IN CASE	250-0552
ENCODER 3 SW IN CASE	250-0568
ENCODER 4 SW IN CASE	250-0574

Should you require further assistance, please call;

**R F Solutions Ltd.,
Unit 3, Cliffe Industrial Estate,
South Street,
Lewes,
E. Sussex. BN8 6JL.
England.**

Tel: +44 (0)1273 898 000 Fax: +44 (0)1273 480 661

Email : sales@rfsolutions.co.uk

<http://www.rfsolutions.co.uk>

