

FEATURES

- MINIATURE SYNTEHSISED MODULE
- DATA RATE UP TO 9600bps
- NO OPERATING LICENCE REQUIRED
- 5 - 500mW OUTPUT POWER
- 10 - 20km RANGE (Direct Line of Sight)
- 1-3km RANGE (Within Buildings)
- 32 RF CHANNELS SET BY 6 DIL SWITCHES OR SERIAL PORT OR BY INCREMENTAL LPULSE
- WIDE Tx VOLTAGE RANGE 8.5 - 14V DC
- TYPE APPROVED TO MPT1329 & ETSI300-220
- FREQUENCY RANGE 458.525 - 458.925MHz
- SIZE 93 X 60 X 17mm
- ANTENNA CONNECTION: MCX



DESCRIPTION

The R.F. Solutions 458MHz FM Transceiver Module is a compact frequency synthesised module capable of transmitting data up to 20 kilometres in direct line of sight, up to 1-3km within buildings. The units are suitable for general purpose telemetry applications where small size and high data rates are needed. The module can transmit digital or analogue (GMSK, or FSK) data at up to 9600baud rate.

The output power and frequency channel is user selectable, to ensure that an open channel may be employed.

Supplied as a completed module, no modification or pre tuning is necessary. Connections to the module are via a 26 way connector on the module base. The transmitter has three data inputs, Digital, Analogue, and direct modulation. Two data outputs are provided one digital and one analogue. The transmitter and receiver sections may be switched independently via external signal lines.

The transmitter section has three data inputs: one for Analogue Data (AIN), one for Digital Data (DIN) and one for Direct Modulation (MIN). Two data outputs are provided from the receiver section, these are: Digital Data Out (DOUT) and Analogue Data Out (AOUT).

The transmitter and receiver can be switched independently by signals (TXON) and (RXON). Additional signals are provided such as relative signal strength indication (RSSI), RF Carrier Direct (CD), Synthesiser Locked (RDY) and Out of Lock (OOL).

The RF frequency can be set in three ways. The 6 DIL switches located at the front of the module set the default RF frequency. This can be incremented or decremented by pulsing the input (FINC) in conjunction with the clock input (FCLK). In addition a Serial Data Stream can be used to set the RF frequency directly and interrogate the status of the radio. Other output signals provided are Relative Signal strength, Carrier Detect, Synthesiser Locked, Out of Lock. The RF output power can be set between 5mW and 500mW by the (RFADJ) signal.

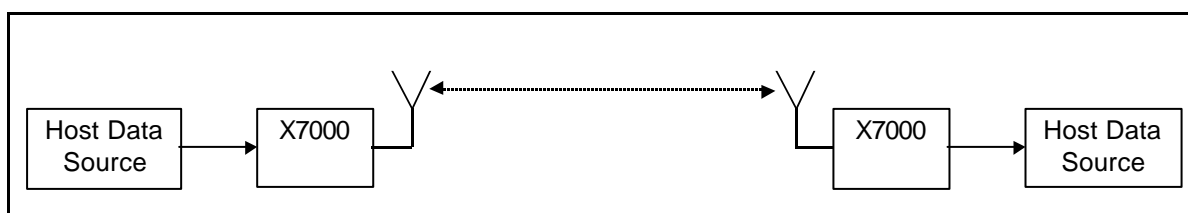

This transceiver requires no licence to operate and is type approved to MPT1329 and ETSI300-220.

TYPICAL OPERATION

Frequency of Operation

The transceiver operate on the 458.500MHz to 458.950MHz telemetry band. There are 32 channels within this band at 12.5KHz or 15 channels at 25KHz bandwidth.

The 5 DIL switches accessed from the top of the module set the RF frequency after power is applied or a RST has occurred. The following frequencies will be set on the standard UK version:

Ch No (Hex)	Frequency (MHz)	SW5	SW4	SW3	SW2	SW1
02	458.525	ON	ON	ON	ON	OFF
04	458.550	ON	ON	ON	OFF	ON
06	458.575	ON	ON	ON	OFF	OFF
08	458.600	ON	ON	OFF	ON	ON
0A	458.625	ON	ON	OFF	ON	OFF
0C	458.650	ON	ON	OFF	OFF	ON
0E	458.675	ON	ON	OFF	OFF	OFF
10	458.700	ON	OFF	ON	ON	ON
12	458.725	ON	OFF	ON	ON	OFF
14	458.750	ON	OFF	ON	OFF	ON
16	458.775	ON	OFF	ON	OFF	OFF
18	458.800	ON	OFF	OFF	ON	ON
1A*	458.825*	ON	OFF	OFF	ON	OFF
1C	458.850	ON	OFF	OFF	OFF	ON
1E	458.875	ON	OFF	OFF	OFF	OFF
20*	458.900*	OFF	ON	ON	ON	ON
22	458.925	OFF	ON	ON	ON	OFF

* Excluded from MPT1329 approval and cannot be used for transmission.

Radio Propagation

With any radio system, there are a number of factors affecting the system performance. These are

- Transmitter power output
- Height of transmitter and receiver antenna
- Length of feeder cables to the antenna
- Type and efficiency of antenna
- Surrounding topography
- The weather

Antennas

The types of antenna we recommend for this Modem are;

Helical : The smallest, most compact antenna, has a gain of 0.5, designed for short ranges up to 2km

1/4 Wave Flexi : General purpose antenna with gain <1 gives slightly better range than Helical

Yagi : A highly directional antenna (Looks similar to a standard TV aerial). Typically has a gain of >2dB. The output power of a transmitter connected to a Yagi must be reduced in order to comply to the DTI specifications. This does however have the advantage of reducing the power consumed by the transmitter to achieve the same range. By connecting a Yagi to a receiver, the system range may be extended to 20km.

Note : Try to keep the feed wire to the antenna as short as possible, If the antenna is to be mounted some distance away 50Ω low loss co-axial cable should be used as the interconnection.

CONNECTIONS

Pin	Signal	Direction	Description
1	GND	IN	0V Power Supply
3	NU		Not Used
5	OOL	OUT	Out of Lock Signal. Output set low if synthesiser has not locked within 70mSec of TXON or RXON being applied.
7	SOX	OUT	Serial status Data Out. Used in conjunction with SRX
9	STX	OUT	Serial status data; TTL Level 9600baud no parity
11	SRX	IN	Serial set-up data; TTL Level 9600baud no parity
13	TXON	IN	Set low to switch on the transmitter
15	RSSI	OUT	Voltage logarithmically proportional to signal strength 0V=No signal, 0.7V = 0.1mV, 1.6V = 10 mV, 2.4V = 100 mV
17	DIN	IN	Digital Signal : 100kΩ input impedance DC - 9600bps 2.5V threshold
19	MIN	IN	Direct Modulation : 10kΩ input impedance DC - 9600bps + / - 3Vpk-pk for full deviation
21	AOUT	OUT	Receiver Analogue Signal : Max Deviation = 1.8V pk-pk Bias Voltage = 2.8V
23	NU		Not Used
25	DOUT	OUT	Receiver Digital Signal. The ANOUT signal is processed and presented in digital form.
2	RFADJ	IN	Sets the output Power. Floating input = Max RF Power 0.4 - 0.5V = 5 – 500mW
4	SIX	OUT	Low when serial status data is present on STX
6	RST	IN	Held low to reset module
8	RXON	IN	Set Low to switch the receiver on. Used in conjunction with TXON: TXON RXON FUNCTION Low Low Transmit Low High Transmit High Low Receive High High Power Down
10	FCNT	IN	High to low transition increments or decrements the RF channel.
12	FDIR	IN	HIGH sets FCNT to increment channel LOW sets FCNT to decrement channel
14/16	MUX1/M UX2	IN	MUX1 and MUX2 connect one of the three data inputs to the transmitter in the following way: MUX1 Mux2 INPUT High High DIN Low High AIN High Low MIN
18	AIN	IN	Analogue Signal : Maximum deviation at 1Vpk-pk, bandwidth 6Hz to 4KHz, 3KΩ input impedance
20	RDY	OUT	Set low when synthesiser has locked
22	TRD	OUT	Set high when in transmit or receive
24	+VE	IN	Power Supply +ve, regulated 8.5 - 14V supply.
26	CD	OUT	Carrier Detect; high when an RF signal of sufficient strength is present
A	GND	IN	0 Volts
B	+Ve	IN	Power Supply +ve, regulated 8.5 - 14V supply.

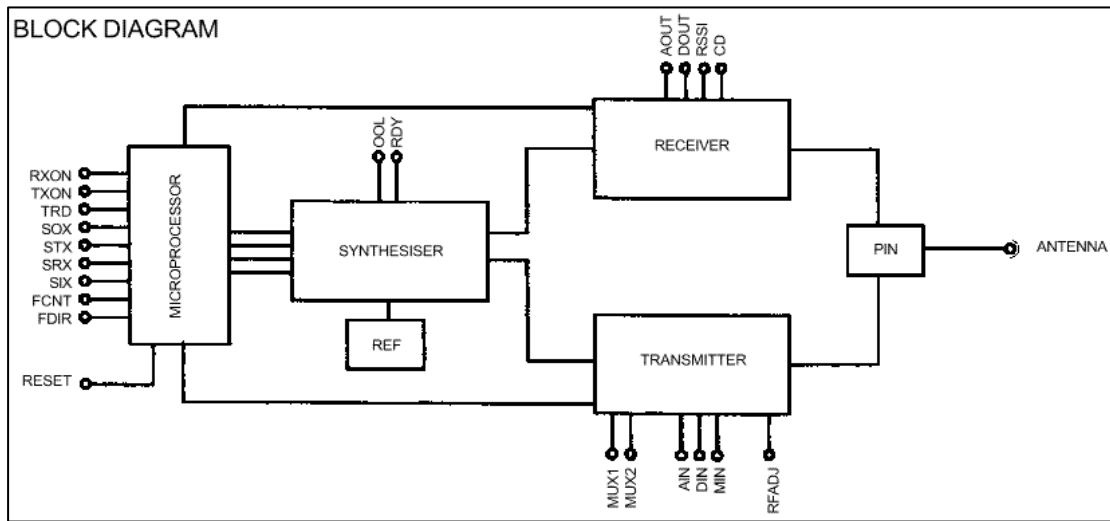

OPERATION

OOL The Out of Lock signal is set low by two radio module if the synthesiser has not locked within 70mSec of ,either TXON or RXON being asserted

SOX The SOX input can be used to send serial commands to the module or pass serial data to the transmitter.

The command character 02H sent to SRX will divert all following serial data to the SOX output. This output can be connected to the DIN digital input hence only one serial port is needed to control the radio module status and transmit serial data over the air.

STX/SRX The STX output and the SRX input can be used to interrogate the X7000 Radio Module via a serial port and set the following parameters.

- RF Channel Change
- Power Down Mode
- Transmit Mode
- Receive Mode
- Initialise Mode
- Status Report

The SRX port receives serial data from an external source and the STX transmits serial data from the X7000 radio module Both operate at half duplex, TTL levels, 9600 baud 8 data bits. 1 stop bit, and no parity. A start bit is defined as a transition from 5V to 0V

Serial Protocol

The X7000 Module is interrogated on the SRX pin by the host sending 05H. The module will send an acknowledge byte from STX of 06H.

The host has 3.6sec to send one Of the following command bytes:

- 49H Initialise Channels. Forces both receive and transmit channels to the channel set on the DIL switches.
- 4CH Change Channel. If this character is sent the module will expect two further bytes of data. The first byte will set the RF transmission frequency The second byte will set the RF receive frequency. The channel bytes are shown in the DIL Switch Table

50 H	Power Down Mode	The module will disable the transmitter and receiver thereby reducing the current consumption to approximately 2mA.
54H	Transmit Mode.	Enables the transmitter. Data on DIN, AIN or MIN will be broadcast.
52H	Receiver Mode.	Enables the Receiver. Received data will appear on AOUT and DOUT
53H	Status Report.	Four bytes will be transmitted by the module indicating the current status:
	1st Byte	Acknowledge 53H
	2nd Byte	Transmission channel number
	3rd Byte	Receiver channel number
	4th Byte	Module Status:
		00H Module powered down
		02H Receive mode
		04H Transmit mode
		22H Receiver synthesiser not locked
		32H Transmitter synthesiser not locked

TXON

The TXON input is set low to switch on the transmitter stage.

RSSI

The relative signal strength indication provides a voltage which is logarithmically proportional to the RF signal strength:

- 0.0V = No RF signal strength
- 0.7V = 1µV RF signal. strength
- 1.6V = 10µV RF signal strength
- 2.4V = 100µV RF signal strength
- 2.7V = 1mV RF signal strength

DIN

The digital modulation input accepts digital serial data from DC to 10kbps. It has a threshold of 2.5V with an input impedance of 100kΩ.

MIN

The MIN input can be used to directly modulate the transmitter. A 3V p-p signal on a 2.5V bias voltage will produce full deviation of ± 3KHz. There is no filtering on the input therefore care must be taken not to infringe the MPT1 329 specification on adjacent channel power limits. If this input is used the equipment might have to be type approved again.

AOUT

A demodulated analogue signal is presented. A full deviation of +1-3KHz will produce a 1.8Vp-p signal on a 2.8V DC bias.

DOUT

The DOUT output signal is a digitised version of the AOUT analogue signal. The peak and trough limits of AOUT are measured and a midway level is generated. A comparator compares the level with AOUT and the digitised DOUT signal is produced.

When transmitting a long data stream it is important to transmit an equal mark and space ratio if possible. A long stream of either marks (FFH) or spaces (00H) can cause problems. In addition a preamble such as 55H, AA or CCH is required at the start of each data, stream so that the midway level can be established before the data is received.

RFADJ

The RF output level can be regulated from this input. An open circuit will produce the maximum output power or 500mW. If 0V is applied to RFADJ then the minimum output power of 5mW will be set.

The RF output power can be adjusted between the maximum and minimum by setting a voltage of between 0.4V to 0.5V. This adjustment will be affected by both component tolerance and temperature.

SIX

The SIX output is set low when data is present on the STX output.

RST The RST input when held low will reset the internal microprocessor.

RXON The RXON input is used in conjunction with the TXON input to switch the module into the receive mode, the transmit mode or the standby mode in the following way:

TXON	RXON	FUNCTION
Low	Low	Transmit
High	Low	Receive
Low	High	Transmit
High	High	Power Down

FCNT The FCNT input is used in conjunction with the FDIR input to increment or decrement the RF channel by means of an external switch closure. The input has internal switch debounce and a transition from high to low will cause the RF channel to change.

FDIR The FDIR input sets the direction in which the RF channel will change. If FDIR is high then when FCNT is changed from high to low the RF channel will be incremented. If FDIR is low then when FCNT is changed from high to low the RF channel will be decremented.

MUX1/MUX2 MUX1 and MUX2 are used to connect one of the three data inputs to the transmitter in the following way:

MUX1	MUX2	INPUT
High	High	DIN
Low	High	AIN
High	Low	MIN

AIN The AIN input accepts analogue modulation data. A 1Vp-p signal will cause maximum frequency deviation of +/- 3kHz. The Input has a bandwidth of 6Hz to 5KHz with an input Impedance of 3k Ω .

RDY The RDY output is set low when the synthesiser has locked. In the transmit mode RDY can be used to give an indication that the module is ready to transmit data. If the module is switched on or from the standby mode to the receive mode, RDY can be used to indicate that the receiver is operational.

TRD The TRD output is set high when the module is in the transmit mode or the receive mode

+VE The +VE input is the second of two directly connected supply inputs. A regulated 8.5V to 14V power supply capable of supplying the following current:

Transmit Mode 350mA (inrush Current = 700mA for 20msec.)
Receive Mode 70mA
Standby Mode 2mA

The power supply should have a ripple voltage of <50mV on load. Some switch mode power supplies can produce RF frequencies which will cause interference to the receiver signal.

CD The CD output is set high when the receiver detects an RF carrier. The threshold is factory set to 2 μ V but this can be adjusted to be more or less sensitive by a potentiometer on the underside of the module.

NOTE: All digital inputs are pulled up via 100k Ω resistors. They should not be connected directly to the power rail

BASIC TRANSCEIVER

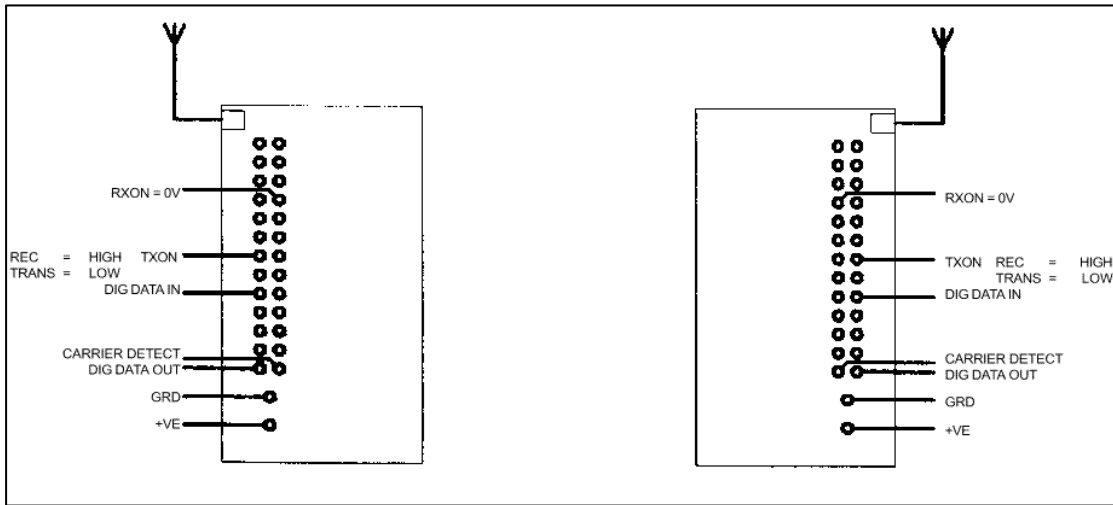

SERIAL CONTROL

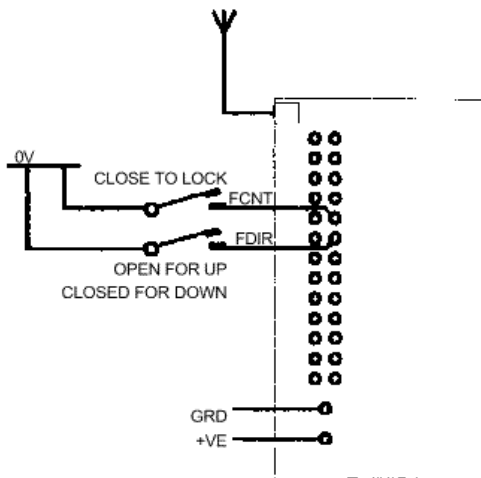

SWITCH CONTROL

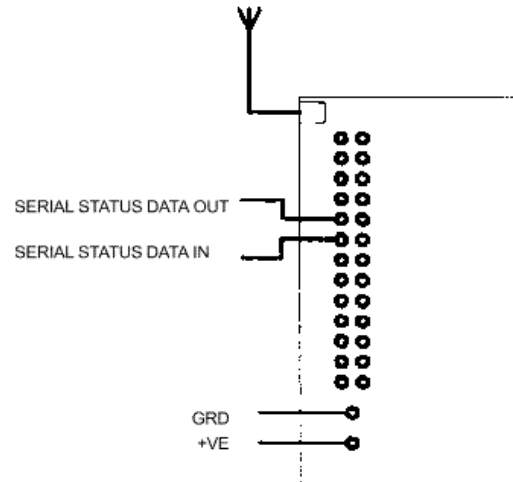

ABSOLUTE MAXIMUM RATINGS

Storage Temperature.....-30 to +85° Celsius.
 Operating Temperature.....-10 to +55° Celsius.

WARNING: Improper antenna load can cause damage to the final stage of the transmitter. Always use a 50Ω impedance antenna.

TECHNICAL SPECIFICATION

Ambient temperature = 25° Celsius.

ELECTRICAL CHARACTERISTICS	MIN	TYPICAL	MAX	DIMENSION	NOTE
Transmission Frequency	458.525		458.925	MHz	UK
Transmission Frequency	400		480	MHz	World-Wide
Weight			30	grams	
Supply Voltage	8.5	12	14	V	
Supply Current			5	mA	Standby Mode
Channels		17			
Channel Separation	12.5	25	25	KHz	
Start up Time	5	10	30	mSecs	
Modulation		F3D			
TRANSMITTER					
RF Power Output	5		500	mW	
Supply Current	290	320	350	mA	@ 500mW
Frequency Deviation		+/-3		KHz	@25KHz Channel
Frequency Deviation		+/-1.5		KHz	@12.5KHz Channel
Analogue Input (AIN)		1		Vp-p	+ /- 3KHz Dev
Digital Input (DIN)	0	5	10	V	DC to 10Kbps
Modulation Input (MIN)		3		Vp-p	+ /- 3KHz Dev
Modulation Rate	DC		10	Kbps	
RECEIVER					
Supply current	55	65	70	mA	
Standby mA	1	2	3	mA	
IF Frequencies		45/455		MHz	
Sensitivity		0.3		mV	10dB SINAD
Bandwidth		+/- 7.5		KHz	
Analogue Output (AOUT)	1.8			Vp-p	2K impedance
Digital Output (DOUT)	0	5	5	V	
RSSI	0	2.7		V	2.7v = 1mVFS

Power Supply

Must be regulated and ripple free. It is not advisable to use a switched mode power supply, either to drive the X7000 Modem or within close proximity to it. Switched mode power supplies can produce high energy radio frequencies over a broad spectrum potentially causing interference with the operation of the Modem.

Note : If the direct modulation input is used (MIN) then the radio and the users modulation circuit must be submitted for MPT1329 type approval.

Channel Selection

Channel selection may be effected by either the 5DIL switches, Single step, or via the serial data communication.

MECHANICAL DIMENSIONS

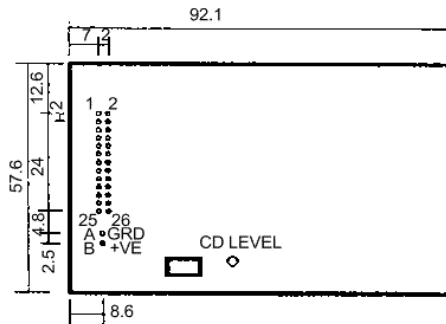

BOTTOM VIEW

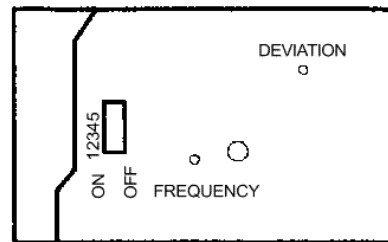

TOP VIEW

ORDERING INFORMATION

PART No	DESCRIPTION
X7000	Synthesised Transceiver 458MHz

**R. F. Solutions Ltd.,
Unit 21, Cliffe Industrial Estate,
South Street,
Lewes,
E Sussex, BN8 6JL. England.**

Tel +44 (0)1273 898 000. Fax +44 (0)1273 480 661.

Email sales@rfsolutions.co.uk <http://www.rfsolutions.co.uk>

RF Solutions is a member of the Low Power Radio Association.



Information contained in this document is believed to be accurate, however no representation or warranty is given and no liability is assumed by R.F. Solutions Ltd. with respect to the accuracy of such information. Use of R.F.Solutions as critical components in life support systems is not authorised except with express written approval from R.F.Solutions Ltd.