

impedance matching transformers 4-72

selection procedure for matching transformers 4-72

selection strategy 4-73

transformers for thyristor drives 4-74

transformer applications in analogue and digital circuits 4-75

digital circuits 4-75

design example : 4-75

design example : 4-77

control circuits 4-80

switching power supplies 4-80

3 phase motor controller 4-81

EMC design considerations 4-81

common mode chokes 4-84

custom and safety approved transformers 4-85

TRANSFORMER APPLICATIONS

Impedance Matching Transformers

impedance matching transformers

Matching is required to ensure maximum power transfer from the source to the load (see figure 1).

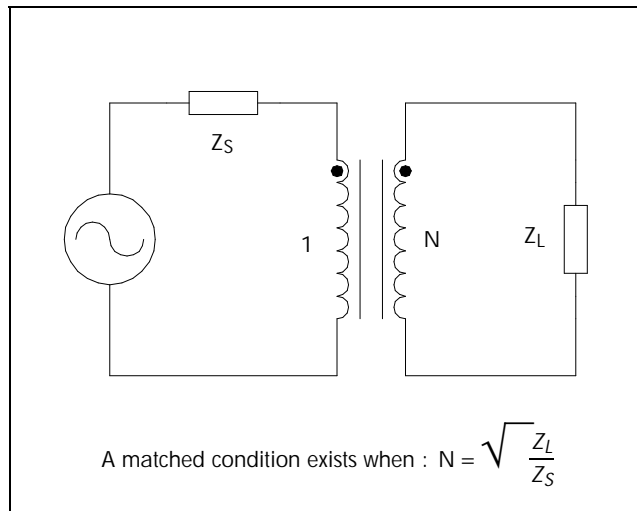

Figure 1 : *Ideal Matching*

In the real world the matching transformer will present its own shunt impedance to the source (see figure 2).

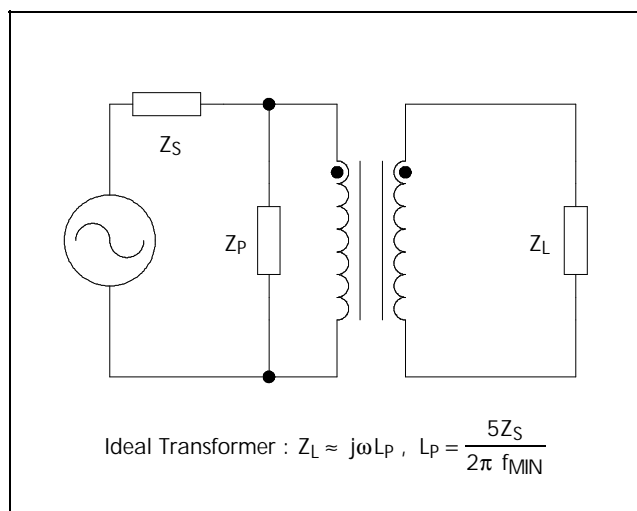

Figure 2 : *Ideal Shunt Impedance*

The magnitude of this impedance will depend on the primary inductance and the frequency of operation. This should be large compared with the source impedance. A safety factor of 5 should be sufficient for most applications. If too high a primary inductance is chosen, the parasitic components (shunt capacitance, leakage inductance etc) conspire to reduce the high-frequency performance of the circuit.

selection procedure for matching transformers

It is necessary to check the pulse distortion when selecting the transformer. There is a maximum area of pulse which a given transformer can transmit; this is known as the Et constant. Figure 3 indicates how this may be estimated from the known pulse shape. It is worth noting that if no upper limit can be put on the value of T_{PW} then it will not be possible to use a transformer in this application - transformers do not work with DC! If too low an Et constant is chosen then the full pulse width will not be transmitted and the transformer will cause excessive loading to the line due to saturation. Conversely, too high an Et constant will bring attendant high parasitic capacitance and inductance which will cause a poor rise time.

The other distortion which should be checked is droop. Figure 3 shows the definition of droop and its relationship with primary inductance. R is the parallel combination of the source and reflected load impedance; for the matched case this will be half the source impedance. Unless otherwise specified a droop of 10% can usually be tolerated. Here again excessive inductance brings increased parasitics and their attendant

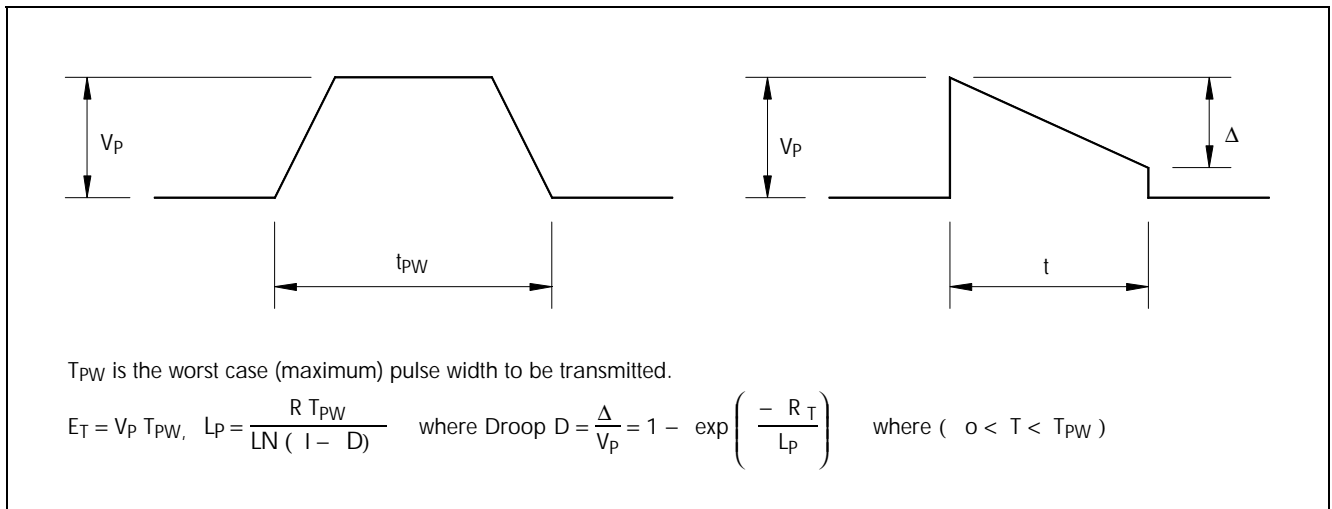

Figure 3 : *Pulse Width and Droop*

problems. From the preceding discussion we can propose a strategy which should enable us to select the correct component in the

majority of applications. The approximations made mean that the strategy has its limitations but the errors are usually negligible.

selection strategy

1. Identify Z_S & Z_L
2. Identify (minimum) operating frequency (f_{MIN})
3. Identify maximum pulse width (T_{PW}) and voltage (V_p)
4. Calculate turns ratio from : $N = \sqrt{\frac{Z_L}{Z_S}}$
5. Calculate minimum primary inductance from : $L_{P_{MIN}} = \frac{2.5 Z_S}{2\pi f_{MIN}}$
6. Calculate minimum E_T constant from : $E_{T_{MIN}} = V_p T_{PW}$
7. Check droop is acceptable (probably < 10%) from : $D = 1 - \exp\left(-\frac{Z_S t_{PW}}{2L_p}\right)$
8. If droop is unacceptable re-calculate L_p from : $L_p = -\frac{Z_S T_{PW}}{2 \ln D}$
9. Select the device that meets the above specification with the lowest values of leakage inductance and interwinding capacitance.

TRANSFORMER APPLICATIONS

Transformers for thyristor drives

transformers for thyristor drives

Transformers are used in thyristor drives to provide isolation of control circuitry and voltage/current transformation. In order for the thyristor to switch on, the gate must be held high until the current in the thyristor exceeds the holding current of the device (see figure 4). This time depends on the device itself and the load characteristics. A resistive load will have a fast current rise time and hence require a narrower pulse than would an inductive load. Unfortunately the majority of applications are for motor drives and it is often difficult to define a figure for maximum pulse duration. It is also important to ensure that the thyristor does not turn on too slowly.

This leads to local 'hot spots' in the device and premature device failure. This requirement means that the transformer should have as low a leakage inductance as possible. For applications where pulse-width-modulation (PWM) techniques are to be employed it should be remembered that it is very difficult, if not impossible, to work pulse transformers at more than 60% mark:space ratio. The reason for this is that the transformer requires time to reset between pulses. If the maximum mark:space ratio is defined along with the operating frequency, the required E_T constant can be readily defined (see figure 5).

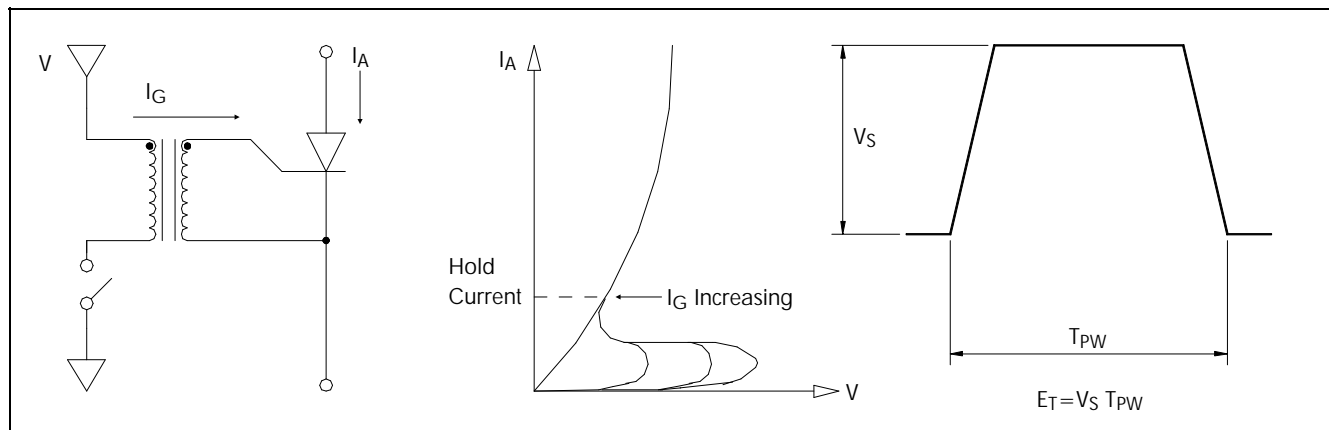

Figure 4 : Thyristor Trigger Pulse

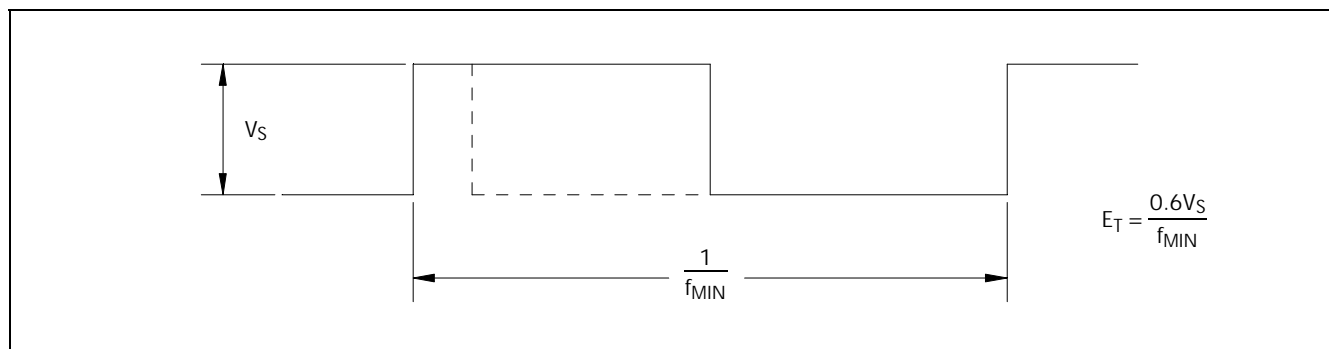

Figure 5 : Mark to Space Ratio

TRANSFORMER APPLICATIONS

Transformer Applications in Analogue and Digital Circuits

transformer applications in analogue and digital circuits

Although often overlooked, the use of transformers in modern electronic equipment is continually expanding. This simple passive element has many features that are irreplaceable using other technologies, such as bi-directional capability, high galvanic isolation and the ability to transfer power as well as data across the isolation barrier, all from a low cost part.

digital circuits

The bi-directional capability of wound transformers is most often found in computer and public telephone networks where isolation is also required. There are a wide range of network isolators available from Newport Components for most popular local area networks (Ethernet, Token Ring etc) that provide some form of signal filtering as well as bi-directional communication and isolation. The isolators are designed to match the line impedance of the cabling system used on the line side and the output termination of the interface IC at the digital termination side (DTE). Many of the pulse transformers available in this data book are suitable for other interface standards, such as IBM 3270 (see figure 6), as well as offering solutions to more exotic networking systems.

In digital audio transmission systems isolation transformers are required to provide good line-to-system matching, improving the balance of transmit and receiver circuits, and reduce common mode noise and EMI. The 766 series offer AES/EBU standards compatible transformers, the 76601/1 is designed to meet AES3 - 199X / IEC958

specification for digital audio transmission and compatible with the crystal semiconductor CS 8401/2 chip sets.

The electrical parameters for the digital audio interface (see figure 7) allow transmission up to a few hundred metres, based on CCITT V.11. Although the above discussion is based on the professional audio standards, by suitable change to the terminating circuits, the design can also be used in a 75Ω consumer audio system.

design example :

passing 50% duty cycle signal through isolating transformers

There are situations when a 50% duty cycle signal can pass through a transformer without problems, providing there is a negative transition to completely de-magnetise the core. If the core is not wholly demagnetised a build up of energy can occur and eventually the pulse can no longer pass through the transformer. In general low frequencies are not a problem as the core is only magnetised for a small part of the pulse period. High frequencies, typically those used in micro-processor timing and digital logic circuits, can cause saturation problems in the core due to magnetic energy build up, especially when transitions are between zero and a positive voltage.

The circuit shown in figure 8 overcomes the problem of passing 50% duty cycle signals through an isolating transformer by sending narrow edge triggered pulses through the transformer, and regenerating the 50% signal on the other side of the isolation barrier. The circuit consists of two edge triggers; one positive edge and one negative edge, an OR

TRANSFORMER APPLICATIONS

Digital Circuits

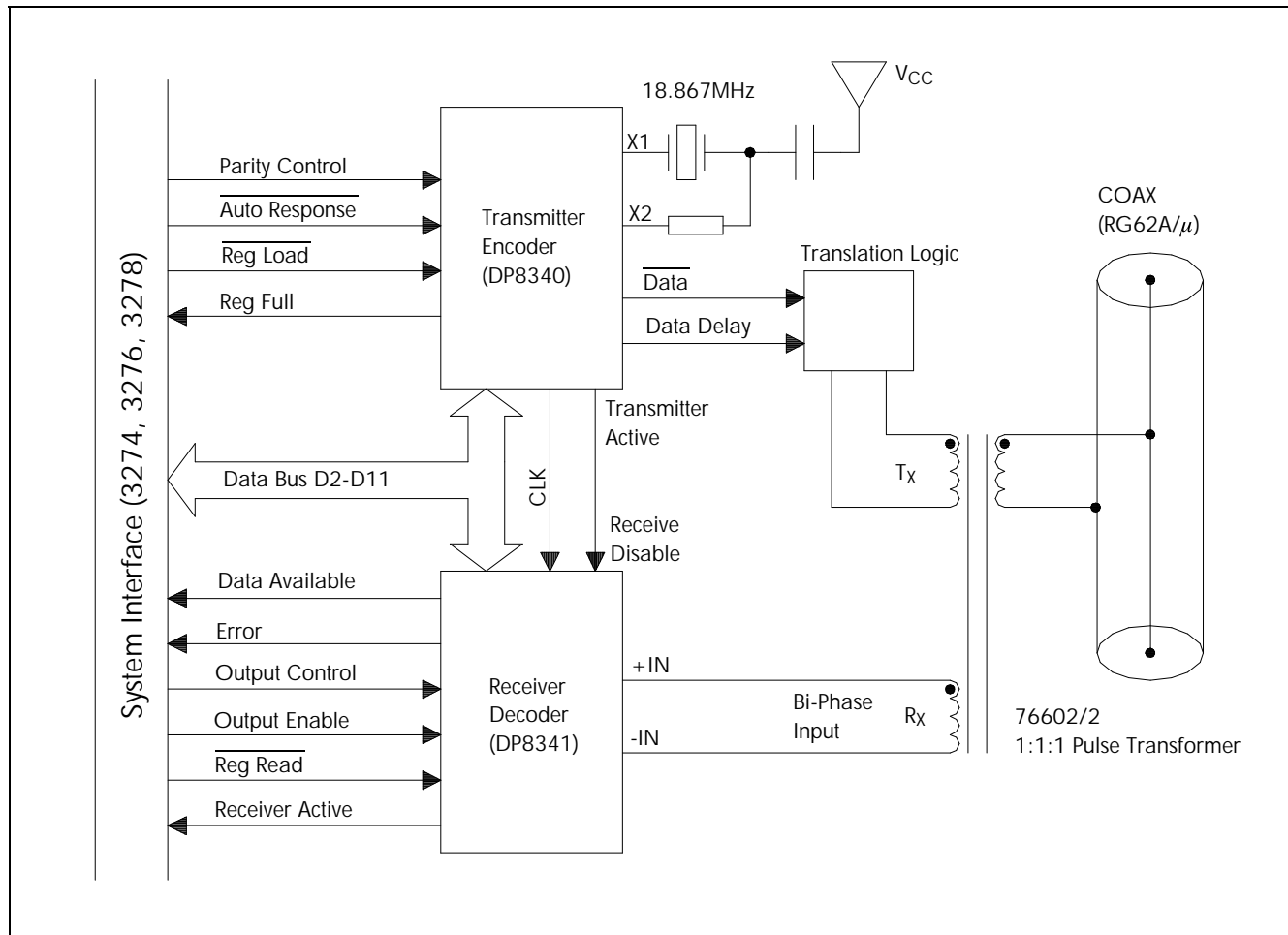

Figure 6 : Typical Applications for IBM 3270 Interface

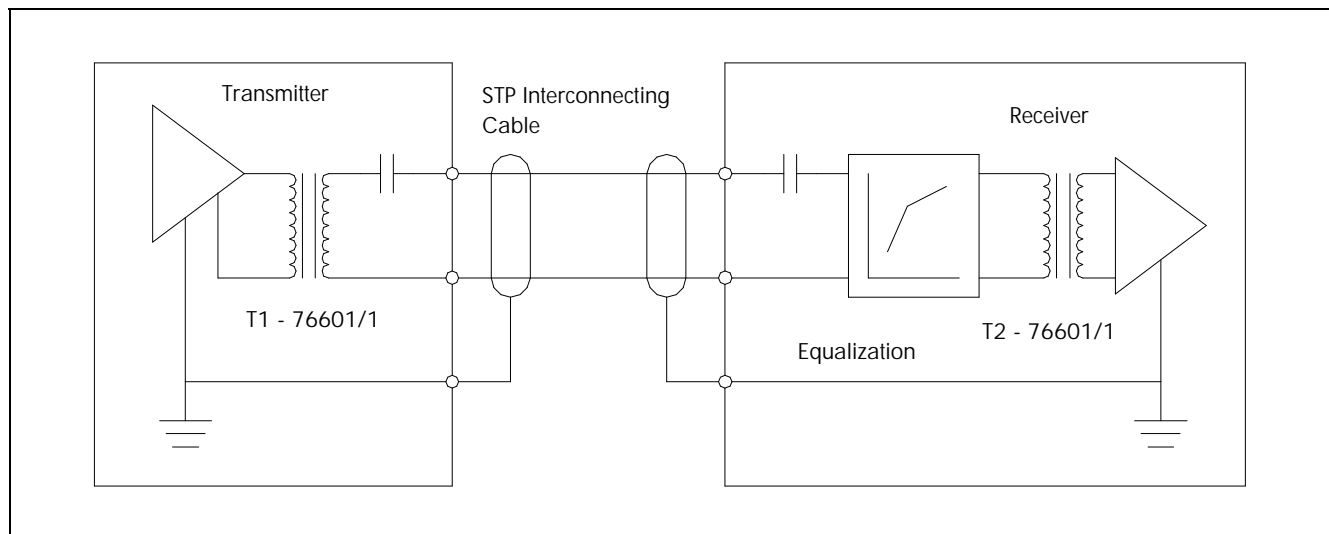

Figure 7 : Digital Audio Transmission System

TRANSFORMER APPLICATIONS

Isolated 3V Digital to 5V Analogue Converter

gate logic driver and a D-type flip-flop divider. The edge detectors produce narrow pulses whose pulse width can be determined by the selection of appropriate R and C values ($2\pi RC$). The narrow pulses are combined at the OR gate to produce a frequency doubled signal with a narrow pulse width. Pulse widths of less than 50% allow the core to easily de-saturate during the 'off' cycle. The 50% duty cycle is regenerated using a D-type flip-flop frequency divider on the other side of the isolation barrier.

The values of resistance and capacitance shown in figure 8 produce the timings given in figure 9. This was tested using a 500kHz signal and standard 74LS logic. Higher frequencies are easily accommodated by reducing the value of capacitor and if necessary using faster logic gates. The application in which this circuit is likely to be most useful is in data bus isolators where data exchange is at high frequency and when passing a clock signal through an isolator.

design example :

isolated 3V digital to 5V analogue converter

When operating a 3V digital system often one is limited by the amount of analogue interface circuitry available in a 3V compatible form. Presented here is a simple design for a 3V digital system to interface with a standard 5V analogue part and maintain isolated power and data. Isolation is required to provide a noise barrier between the analogue measurement system (ADC) and the 3V digital processing circuitry.

The circuit in figure 10 utilises a low power (1W) DC-DC converter for the power isolation (NME0305D) and a transformer isolator/translator for the data interface (1635). The transformer isolator not only provides the galvanic isolation required, but also converts the data signals between 3V and 5V levels, hence no additional level conversion is required. The ADC used is a serial output 8-bit device capable of running at 1MHz clock rates (ZN509E).

Using a four channel isolator allows full control over the ADC to be exercised. Conversion is requested by pulling the chip-select pin low (CS) and a status high for one clock cycle is reported back to acknowledge conversion start. The first data bit (MSB) is then presented onto the data line and all eight bits are transferred with a further status signal at the end of conversion (see figure 11). Conversion can be requested asynchronously with the system clock if necessary and the status flag could be used to poll the controlling logic circuitry.

The circuit works well with clock rates up to 1MHz and offers a high noise immunity of the analogue measurement system from the digital processing circuit. Using a transformer isolator offers a benefit over a similar opto-isolated scheme of conserving power (negligible power is used for the data transfer) and by controlling the supply to the DC-DC the whole analogue system can be 'shut-down' when not required. The serial ADC can easily be replaced by an alternative available from Maxim or Linear Technology and even upgraded to 12 bits without changing any other component in the circuit.

TRANSFORMER APPLICATIONS

Passing 50% Duty Cycle Signals Through Isolating Transformers

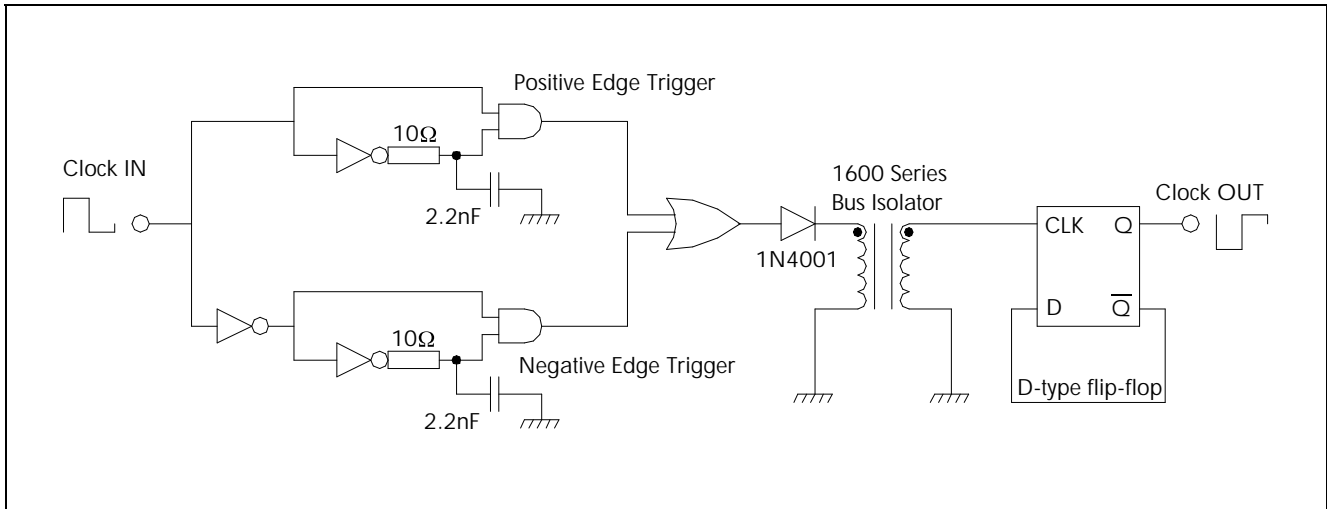

Figure 8 : *Pass 50WF*

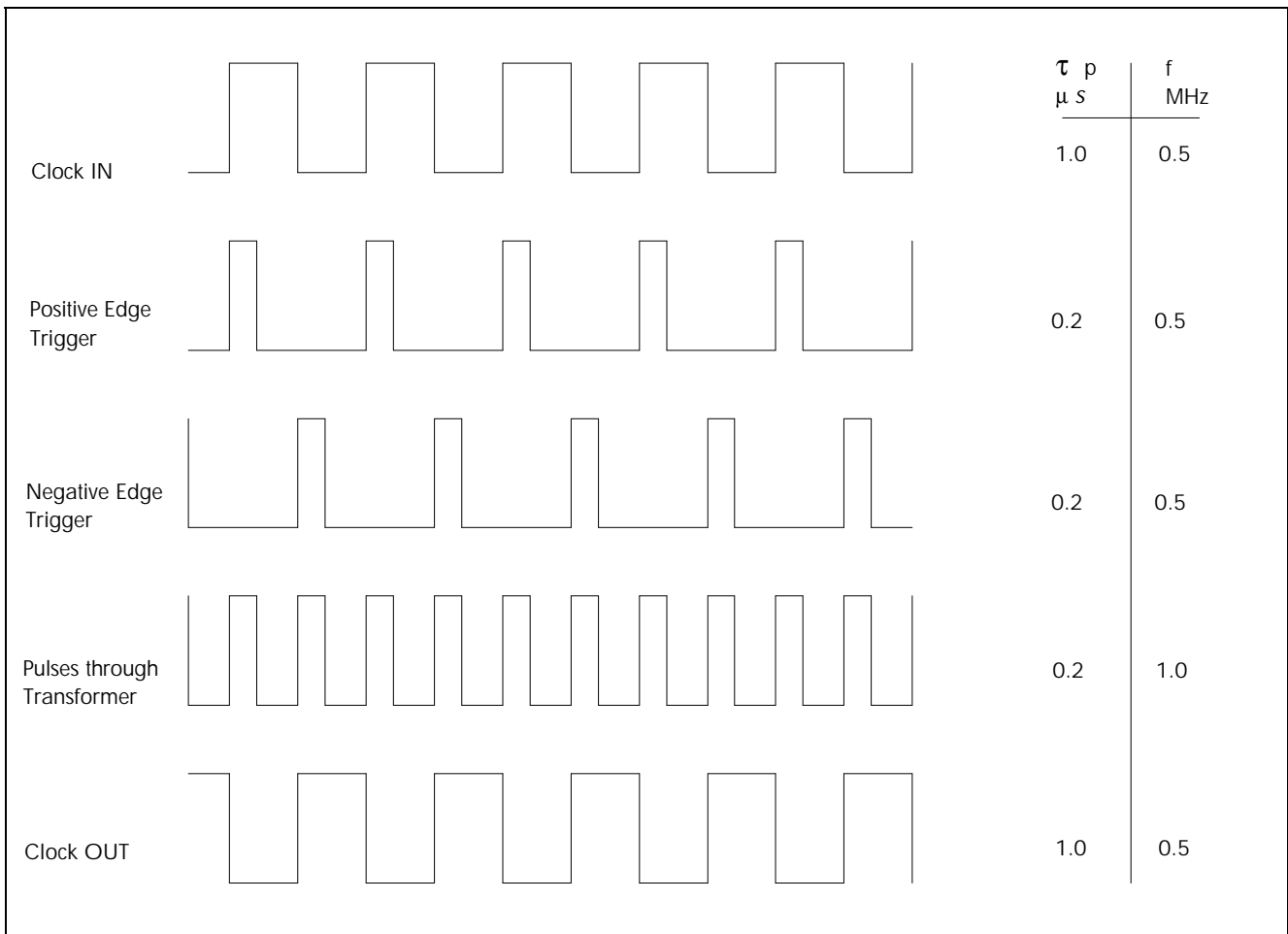

Figure 9 : *Pass 50CC*

TRANSFORMER APPLICATIONS

Isolated 3V Digital to 5V Analogue Converter

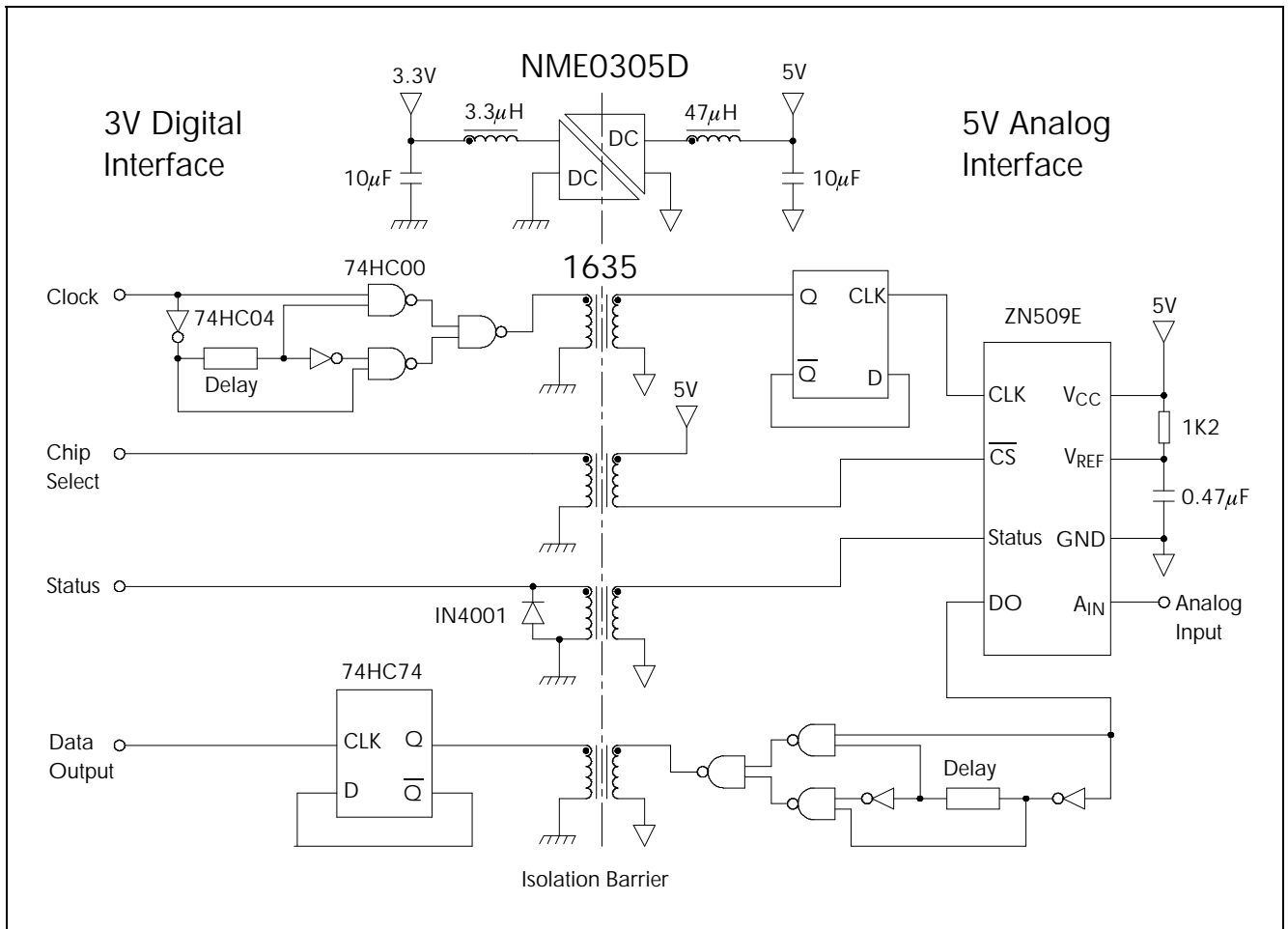

Figure 10 : *Transformer Isolated ADC*

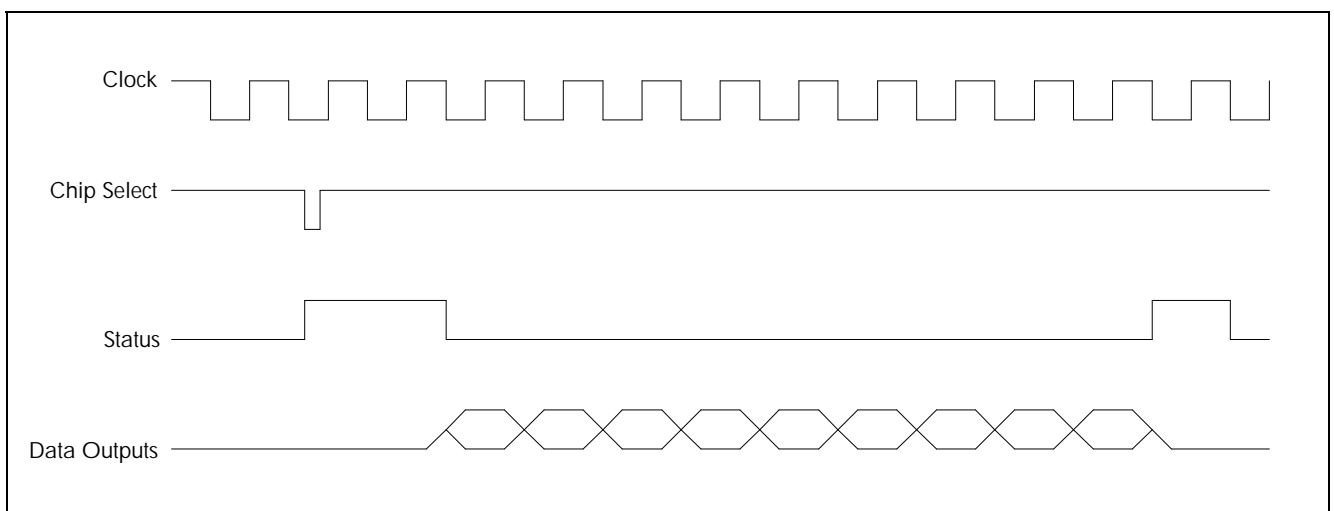

Figure 11 : *Timing Diagram*

TRANSFORMER APPLICATIONS

Control Circuits

control circuits

Isolating the controller from the load has several benefits in both low power and mains powered applications, firstly the controller circuit is protected from any excessive voltages and current present on the load, secondly switching noise from the controlled load and any other load on the same supply line is isolated.

There are several ranges of pulse transformers available from Newport designed to fire a range of different thyristor/SCR/triac gates. These are easy to interface between the gate and control circuitry and can even overcome the problem of insufficient gate drive from the controller by using a step-up winding arrangement to increase the drive voltage at the gate (figure 12). Working voltages of up to 600V rms and isolation barriers of 4000V are available. The technique can equally be applied to three phase controllers and higher operating voltage equipment (see figure 13).

switching power supplies

High efficiency power transfer requires high switching frequencies, hence transformers designed for 50Hz or 60Hz mains are not suitable. There is a range of controller IC's now available off-the-shelf to enable high efficiency switch mode power supplies to be easily constructed. The corresponding transformers are designed to match the operating frequency of these parts to produce high efficiency SMPS designs.

At Newport Components we offer a custom design service for SMPS designs, since we have extensive knowledge of many controller IC's ourselves. Designs are usually made on toroids to enable a low EMI magnetics for operating frequencies of several hundred kHz. Generally higher frequencies are accommodated with RM or pot core designs, suitable for supplies operating in the MHz region.

An example of one transformer for this application that has become a standard

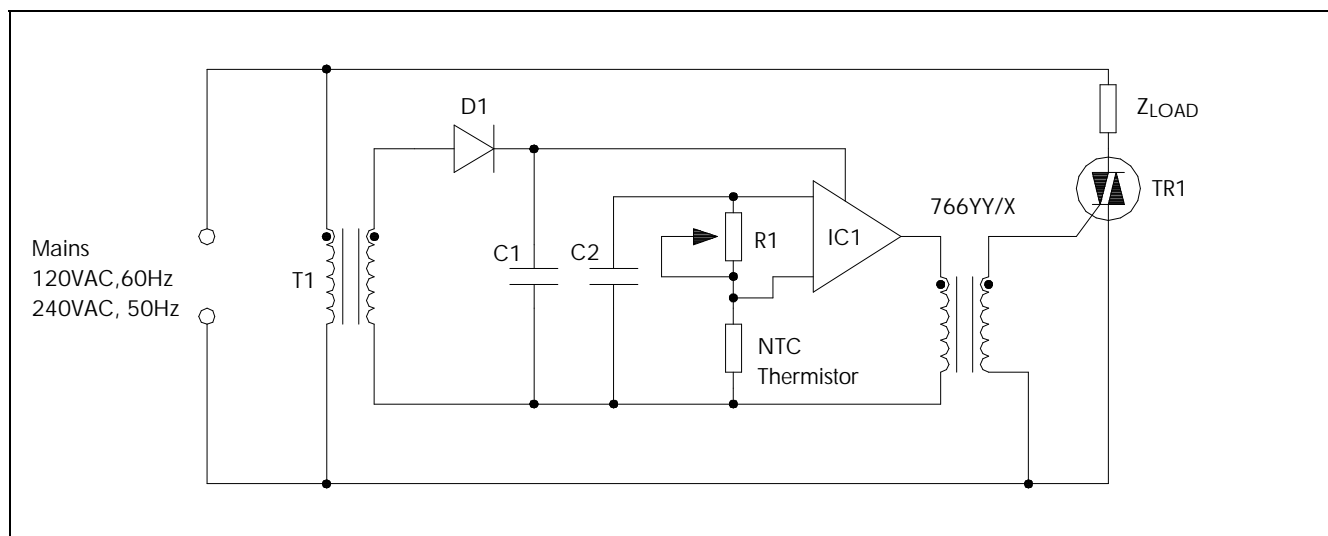

Figure 12 : Simple Isolated Power Controller

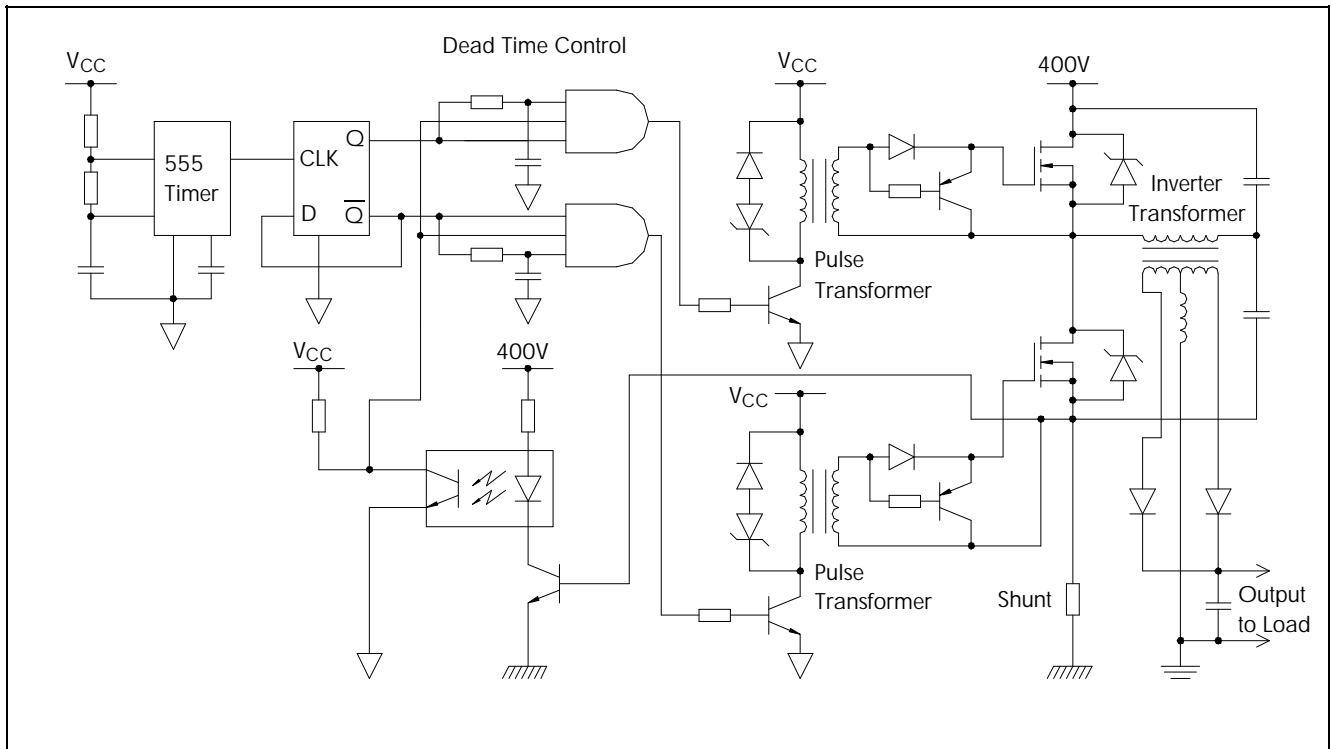

Figure 13 : *Fully Isolated Half Bridge Drive*

product is the 76250 part for use with the Maxim 250/251 chip set to produce an isolated RS232 interface. The transformer provides the power transfer and voltage step-up as well as maintaining the isolation barrier (see figure 14).

3 phase motor controller

The advantage of using pulse transformers in a 3 phase motor controller application (see figure 15) are that a higher isolation is available compared with IGBT devices and there is an inherent overload protection should any phase controller fail (devices are locked off). The isolation barrier between the switching controller system and the motor supply also reduces noise from either system interfering with other controller functions. Further noise and interference suppression

can be obtained by isolating the control bus, either by using logic isolators or a local area control network (see the Newport Components range of Network and Interface Products for more details).

EMC design considerations

The imminent EC regulations regarding electromagnetic compatibility (EMC) will effect many aspects of circuit and system design. However, there are many considerations that can be applied generally to reduce both the emissions from and susceptibility to electromagnetic interfaces (EMI).

There are many areas where the use of transformers in decoupling, isolating and filtering applications will help. As a manu-

APPLICATIONS

TRANSFORMER APPLICATIONS

Switching Power Supplies

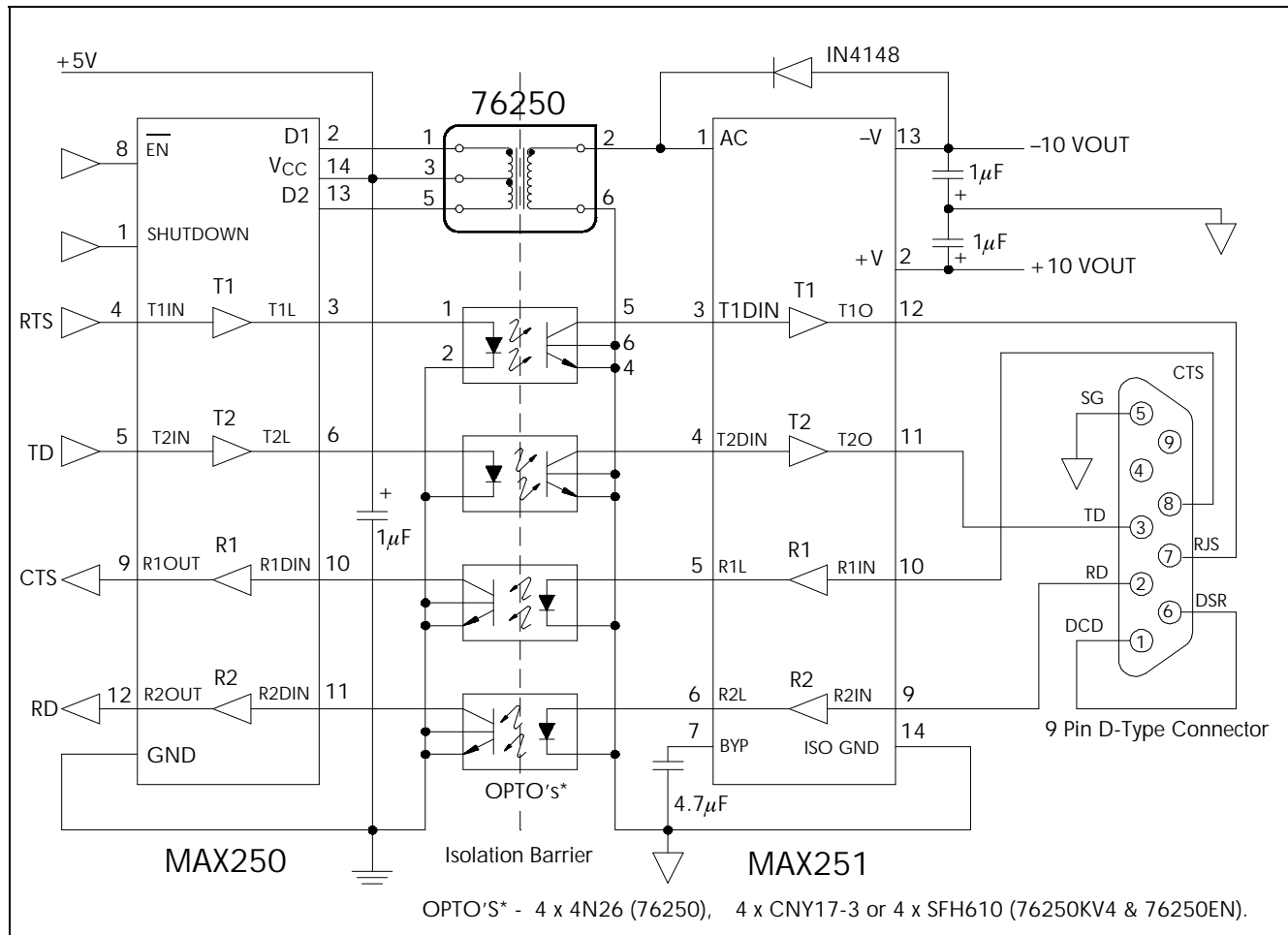

Figure 14 : Isolated RS232 Interface

facturer Newport Components is committed to minimising emissions from its own components and to helping its customers achieve EMC compliance by correct component choice and design. To this end we have compiled the following list of general design considerations:

- reduce high frequency (particularly radio frequency) loops in supply lines
- decouple supply lines at local boundaries (use RCL filters with $Q \leq 2$)
- use low pass filters on signal lines to reduce bandwidth to signal minimum
- keep return and feed loops close on wide bandwidth signal lines
- terminate lines carrying HF or RF signals correctly (this minimises reflection, ringing and overshoot)
- avoid slit apertures in pcb layout, particularly in ground planes or near current paths
- use common mode chokes between current carrying and signal lines to increase coupling and cancel stray fields

TRANSFORMER APPLICATIONS

3 Phase Motor Controller

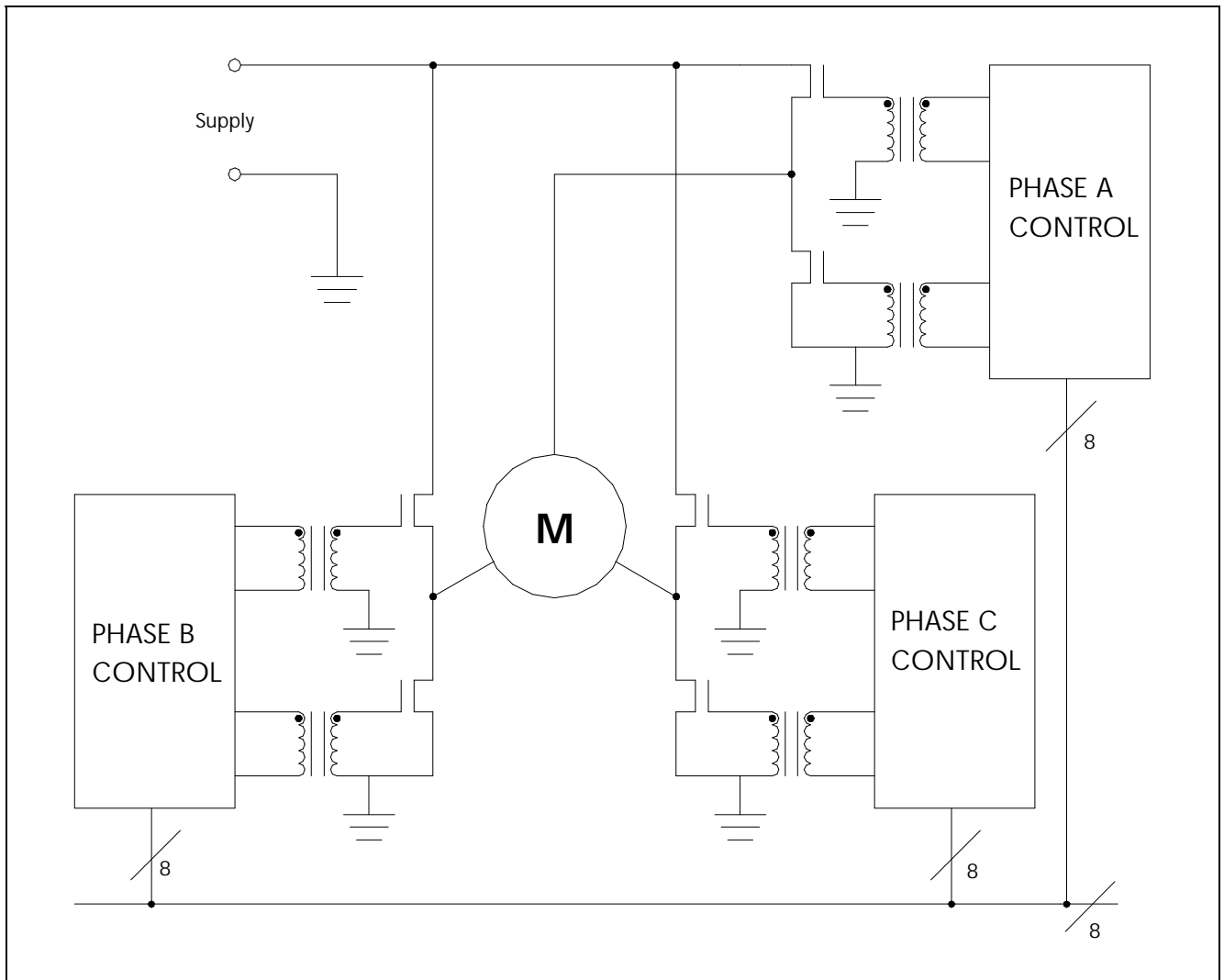

Figure 15 : 3 Phase Motor Controller

- use discrete components and filters where possible
- ensure filtering of cables and over voltage protection (this is especially true of cabling that is external to the system, If possible all external cabling should be isolated at the equipment boundary)
- isolate individual systems where possible (especially analogue and digital systems, on both power supply and signal lines)

- if available, use shielding on fast switching circuits, mains power supply components and low power circuitry.

In general, keeping the bandwidth of all parts of the system to a minimum and isolating circuits where possible reduces susceptibility and emissions.

Transformers can be used for both correct termination and filtering of signal and power lines.

TRANSFORMER APPLICATIONS

Common Mode Chokes

common mode chokes

Many of the 1:1 ratio transformers described in this data book can be utilised as either common or differential mode chokes. The 766 series are particularly well suited to signal lines, where very low DC resistance and good coupling provide excellent common

mode properties. Newport Components can design a common mode choke for either power or signal applications to a customer's requirement and are always open to suggestions. We may even already have a design that is suitable for the application being considered.

custom and safety approved transformers

The data book illustrates the range of standard transformers available from Newport Components. We also have an extensive portfolio of customised transformers based on the standard range and other core formers not featured in this data book.

The 76250 and 76253 series feature safety approved products in their range which are

pin compatible with their non-approved counterparts. Customised safety approved transformers can also be designed for other applications and for parts in our standard 766 range.

Newport Components have an experienced background in both custom design and design for safety approval. If you have a specific request which is not covered in our standard range please call our technical help desk for further information.

