

Design Idea DI-5

TinySwitch™

1.5 W AC Adapter



Application	Device	Power Output	Input Voltage	Output Voltage	Topology
AC Adapter	TNY254	1.5 W	85 - 265 VAC	9 V ± 5%	Flyback

Design Highlights

- Cost competitive with linear solutions
- Lowest component count switching solution
- Universal AC input range
- Ultra low no load power consumption (30/70 mW for 115/230 VAC input)
- Simple, two winding transformer, no tape required
- Low average EMI, no inductive EMI filter components
- Small physical size

Operation

The *TinySwitch* flyback supply generates a single isolated output voltage from a universal range AC input. The basic design can be scaled up to a maximum power of 2 W with a different transformer design and 3.3 μ F input filter capacitors (C1, C2). Typical applications are wall mount AC adapters and other applications requiring extremely low system cost and

small size. The circuit is designed to replace conventional linear supplies, offering universal input range, smaller size, and high efficiency at a competitive cost. Another significant advantage of the *TinySwitch* solution is that it practically eliminates energy consumption at zero load. Typical linear supplies consume 1-4 watts at no load, which translates to \$1-\$4 per year in energy cost at a rate of \$0.12/kWhr.

The example shown below delivers 9 V at 170 mA. Input voltage range is 85-265 VAC. Incoming AC is rectified and filtered by D1-D4, R2, R3, C1, and C2, providing a DC voltage to pin 1 of T1. C4 is the *TinySwitch* bypass capacitor.

R4 and C3 damp the primary leakage spike at the *TinySwitch* DRAIN pin and also reduce EMI. At this power level, a simple RC network is sufficient for this function. Since the *TinySwitch* runs in current limit mode at all times regardless of output loading, the worst case leakage spike and the appropriate values of R4 and C3 required for snubbing are easily determined.

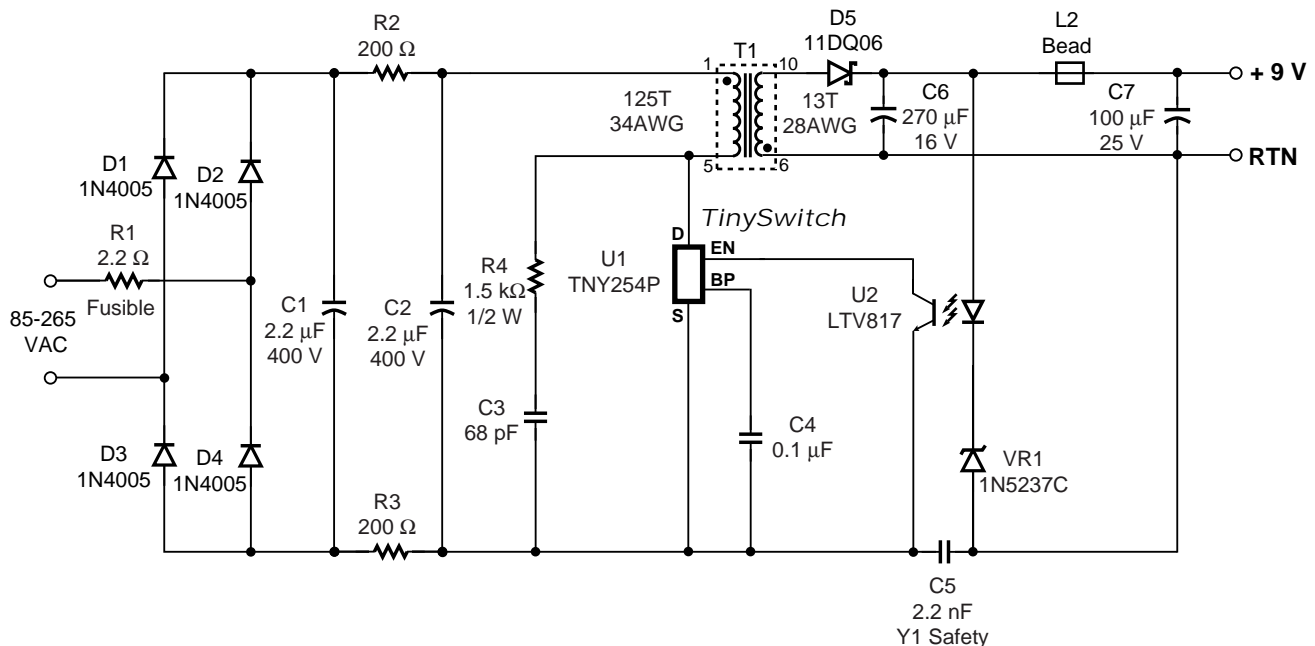

Figure 1. *TinySwitch* 1.5 W Adapter.

PI-2281-102098

The low operating frequency of the TNY254 (44 kHz), allows a low cost snubber circuit C3 and R4 to be used in place of a primary clamp circuit. In addition to limiting the DRAIN turn off voltage spike to a safe value, the RC snubber also reduces EMI by lowering the dv/dt of the DRAIN waveform, which reduces filtering requirements. On fixed frequency PWM and RCC circuits use of a snubber will result in an undesirable fixed AC switching loss that is independent of load. The ON/OFF control on the *TinySwitch* eliminates this problem by scaling the effective switching frequency and therefore, switching loss linearly with load. Thus the efficiency of the supply stays relatively constant down to a very low load.

The secondary winding of T1 is rectified and filtered by D5, C6, L2, and C7 to provide 9 V. VR1 and U2 sense the output voltage and provide feedback to *TinySwitch*. The output voltage is set by the combined voltage drops of Zener diode VR1 and the LED of U2.

C1, C2, R2, R3, and Y-capacitor C5 provide EMI filtering for the power supply. R1 is a fusible resistor for protection against primary fault conditions. This is a low cost alternative to a fuse, accepted by safety agencies.

In this circuit, the converter runs in discontinuous conduction mode at the TNY254 current limit, with a fixed on-time for a given input bus voltage. Instead of controlling the duty factor of each individual switching cycle, regulation is accomplished by gating the number of switching cycles in a given time period via the signal applied to the ENABLE pin. Due to the ON/OFF nature of the *TinySwitch* control scheme, the current transfer ratio (CTR) of the optocoupler is not critical, so that a low cost ungraded device can be used.

For the latest updates, visit our website: www.powerint.com

Power Integrations reserves the right to make changes to its products at any time to improve reliability or manufacturability. Power Integrations does not assume any liability arising from the use of any device or circuit described herein, nor does it convey any license under its patent rights or the rights of others.

PI Logo and *TOPSwitch* are registered trademarks of Power Integrations, Inc.

©Copyright 1998, Power Integrations, Inc. 477 N. Mathilda Avenue, Sunnyvale, CA 94086

WORLD HEADQUARTERS Power Integrations, Inc. 477 N. Mathilda Avenue Sunnyvale, CA 94086 USA Phone: +1•408•523•9265 Fax: +1•408•523•9365	AMERICAS - EAST Power Integrations Marietta, Georgia Phone: +1•770•424•5152 Fax: +1•770•424•6567	EUROPE & AFRICA Power Integrations (Europe) Ltd. United Kingdom Phone: +44•1753•622•208 Fax: +44•1753•622•209	TAIWAN Power Integrations International Taipei Phone: +886•2•2727•1221 Fax: +886•2•2727•1223
KOREA Power Integrations International Seoul Phone: +82•2•568•7520 Fax: +82•2•568•7474	JAPAN Power Integrations, K.K. Yokohama-shi Phone: +81•45•471•1021 Fax: +81•45•471•3717	INDIA (Technical Support) Innovatech Bangalore Phone: +91•80•226•6023 Fax: +91•80•228•2191	

Transformer Parameters

Core Material	TDK PC40EE13-Z or equiv. Gap for A_L of 160 nH/T ²
Bobbin	Custom EE13 10 pin (Sejin)
Winding Order	Primary (1-5), Secondary (6-10) [triple insulated secondary]
Primary Inductance (Pins 1-5 all others open)	2.5 mH \pm 10% @ 40 kHz
Primary Resonant Frequency (Pins 1-5, all others open)	510 kHz minimum
Leakage Inductance (Pins 1-5, with Pins 6-10 shorted)	102 μ H maximum

Table 1. Transformer Design Parameters.

Key Design Points

- Design transformer for discontinuous mode operation, with *TinySwitch* reaching current limit each cycle.
- R4 and C3 must be sized to limit maximum DRAIN voltage to less than 650 V at high line input and full load. C3 should be \leq 68 pF.
- Accuracy of output voltage can be further improved by placing a resistor across the LED of U2 to provide 1-5 mA additional bias current to the Zener diode (VR1). This slightly increases no load power (15-75 mW).
- Efficiency can be improved by replacing R2 with a parallel combination of a 5 mH inductor and a 4.7 k Ω resistor and R3 by a short.

