

# APPLICATION NOTE

**AN112**

LED decoder drivers: using the NE587

1988 Dec

# LED decoder drivers: using the NE587

# AN112

## LED DECODER DRIVER NE587

The NE587 is latched decoder drivers for LED displays. Figure 1 provides a summary of their features.

The programmable constant-current supplies (fixed or adjustable) are essentially independent of output voltage, power supply voltage, and temperature.

The data (BCD) and  $\overline{LE}$  (latch enable) inputs are low loading and thus are compatible with a data bus system.

Figure 2 shows a block diagram of the NE587. Seven-segment decoding is implemented using a ROM.

- Strobed latch
- Inputs compatible with NMOS, CMOS, DMOS, TTL
- Single 5V supply
- Inputs are compatible with microprocessor bus
- BCD inputs — hexadecimal outputs
- Programmable segment current

SL00717

Figure 1. NE587 LED Driver

## LED DRIVERS AND POWER DISSIPATION CONSIDERATION

LED displays are power hungry devices, and, inevitably, somewhat inefficient in their use of the power supply necessary to drive them. Duty cycle control does afford one way of improving display efficiency, provided that the LEDs are not driven too far into saturation, but the improvement is marginal. Operation at higher peak currents has the added advantage of giving much better matching of light output, both from segment-to-segment and digit-to-digit.

When designing a display system, particular care must be taken to minimize power dissipation within the IC display driver. Since the NE587 output is a constant programmed current source, all the remaining supply voltage which is not dropped across the LED (and the digit driver, if used) will appear across the output of the NE587. Thus, the power dissipation in the NE587 will go up sharply if the display power supply voltage rises. Clearly then, it is good design practice to keep the display supply voltage as low as possible, consistent with proper operation of the output current sources. Inserting a resistor or diode in series with the display supply is a good way of reducing the power dissipation within the integrated circuit segment driver, although, total system power remains the same.

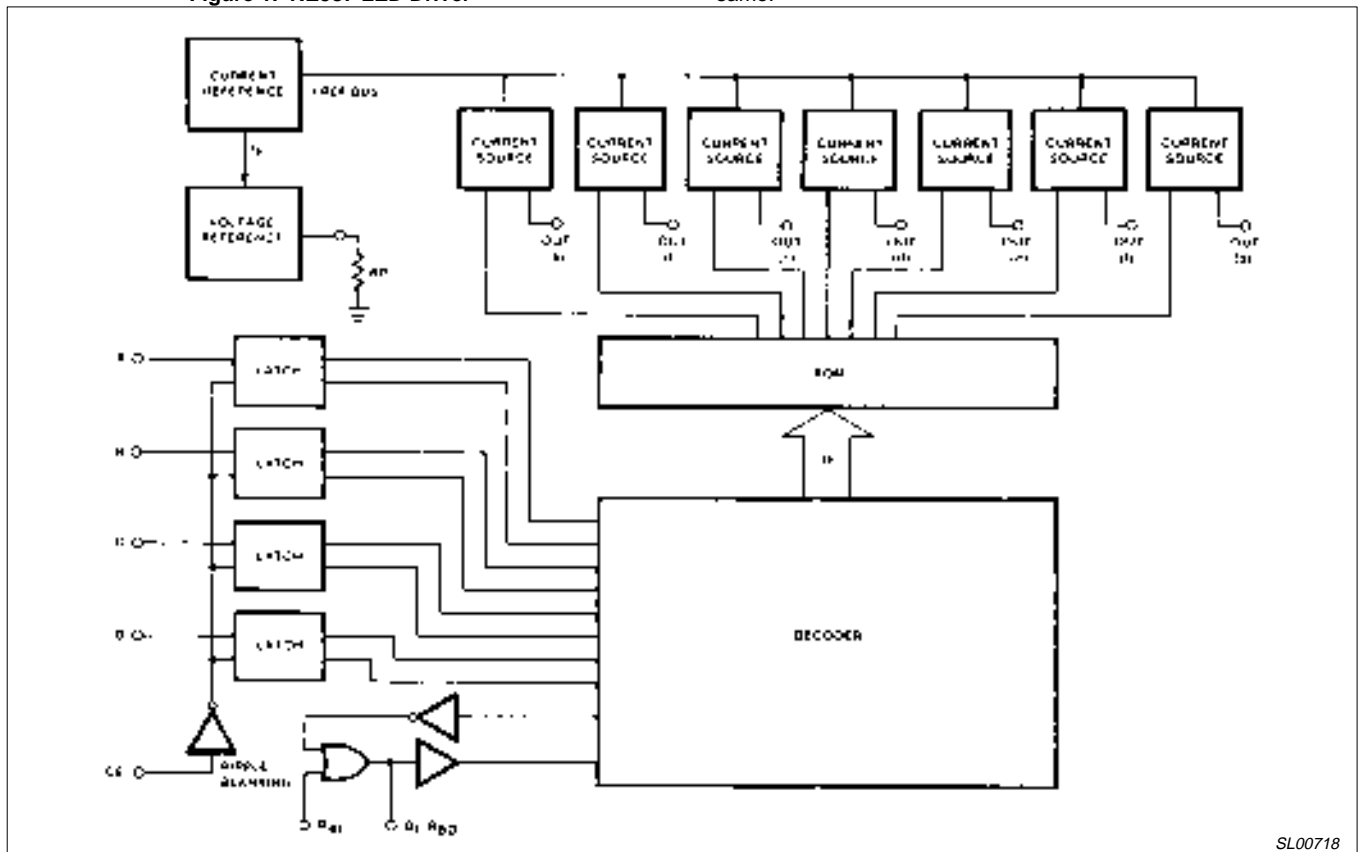

SL00718

Figure 2. NE587 LED Driver Block Diagram

# LED decoder drivers: using the NE587

AN112

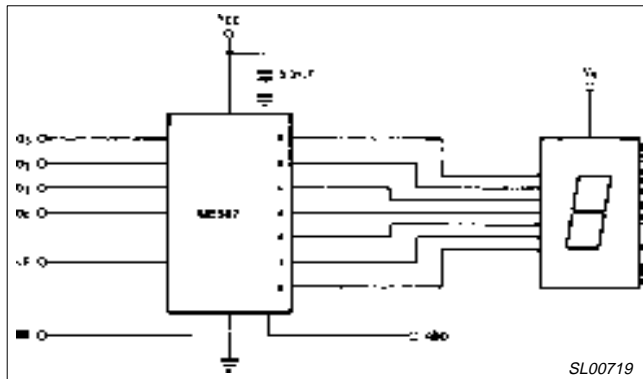

Figure 3. Typical Applications Driving a Single Digit

Power dissipation within the NE587 may be calculated as follows. Referring to Figure 3, the two system power supplies are  $V_{CC}$  and  $V_S$ . In many cases, these will be the same voltage. Necessary parameters are:

- $V_{CC}$  Supply voltage to driver
- $V_S$  Supply voltage to display
- $I_{CC}$  Quiescent supply current of driver
- $I_{SEG}$  LED segment current
- $V_{FLED}$  segment forward voltage at  $I_{SEG}$
- $K_{DC}$  % Duty cycle

$V_F$ , the forward LED drop, depends upon the type of LED material (hence the color) and the forward current. The actual forward voltage drops should be obtained from the LED display manufacturer's literature for the peak segment current selected. However, approximate voltages at nominal rated currents are:

Red	1.6 to 2.0V
Orange	2.0 to 2.5V
Yellow	2.2 to 3.5V
Green	2.5 to 3.5V

These voltages are all for single diode displays. Some early red displays had 2 series LEDs per segment, hence the forward voltage drop was around 3.5V.

Thus a maximum power dissipation calculation when all segments are on, is:

$$P_D = V_{CC} \times I_{CC} + (V_S - V_F) \times 7 \times I_{SEG} \times K_{DC} \text{ mW} \quad (1)$$

Assuming  $V_S = V_{CC} = 5.25V$   
 $V_F = 2.0V$   
 $K_{DC} = 100\%$   
 $I_{SEG} = 30mA$

$$P_{D \text{ MAX}} = 5.25 \times 50 + 3.25 \times 7 \times 30mW = 945mW$$

However, the average power dissipation will be considerably less than this. Assuming 5 segments are on (the average for all output code combinations), then

$$P_{D \text{ AV}} = 5.0 \times 30 + 3.00 \times 5 \times 25mW = 525mW$$

Operating temperature range limitations can be deduced from the power dissipation graph in Figure 4.

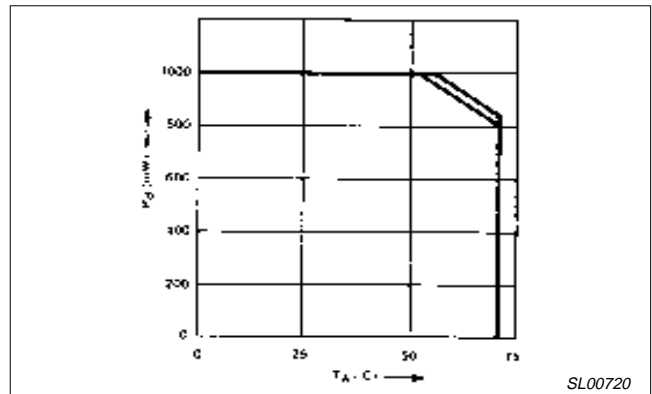

Figure 4. Maximum Power Dissipation vs Temperature

However, a major portion of this power dissipation ( $P_{D \text{ MAX}}$ ) is because the current source output is operating with 3.25V across it. In practice, the outputs operate satisfactorily down to 0.5V, and so the extra voltage may be dropped external to the integrated circuit.

Suppose the worst-case  $V_{CC}/V_S$  supply is 4.75 to 5.25V, and that the maximum  $V_F$  for the LED display is 2.25V. Only 2.75V is required to keep the display active, and hence 2.0V may be dropped externally with a resistor from  $V_{CC}$  to  $V_S$ . The value of this resistor is calculated by using equation 2.

$$R_S = \frac{V_{\text{DROP}}}{I_{SEG} \times \# \text{ of SEG}} \quad (2)$$

or

$$R_S = \frac{2.0}{7 \times I_{SEG}} \approx 10\Omega (1/2W \text{ rating})$$

assuming worst-case  $I_{SEG}$  of 30mA, now:

$$\begin{aligned} P_{D \text{ MAX}} &= V_{CC} \times I_{CC} + (V_S - V_V - R_X \times 7 \times I_{SEG}) \quad (3) \\ &\quad \times 7 \times I_{SEG} \times K_{DC} \\ &= 5.25 \times 50 + 1.25 \times 7 \times 30mW \\ &= 525mW \end{aligned}$$

$$\text{and } P_{D \text{ AV}} = 5.0 \times 30 + 1.25 \times 5 \times 25 = 306mW$$

If a diode (or 2) is used to reduce voltage to the display, then the voltage appearing across the display driver will be independent of the number of "ON" segments and will be equal to

$$V_S - V_F - nV_D, \quad V_D \approx 0.8V$$

Where n is the number of diodes used, and so power dissipation can be calculated in a similar manner.

In a multiplexed display system, the voltage drop across the digit driver must also be considered in computing device power dissipation. It may even be an advantage to use a digit driver which drops an appreciable voltage, rather than the saturating PNP transistors shown in Figure 5. For example, a Darlington PNP or NPN emitter-follower may be preferable. Figure 6 shows the NE591 as the digit driver in a multiplexed display system. The NE591 output drops about 1.8V, which means that the power dissipation is evenly distributed between the two integrated circuits.

# LED decoder drivers: using the NE587

AN112

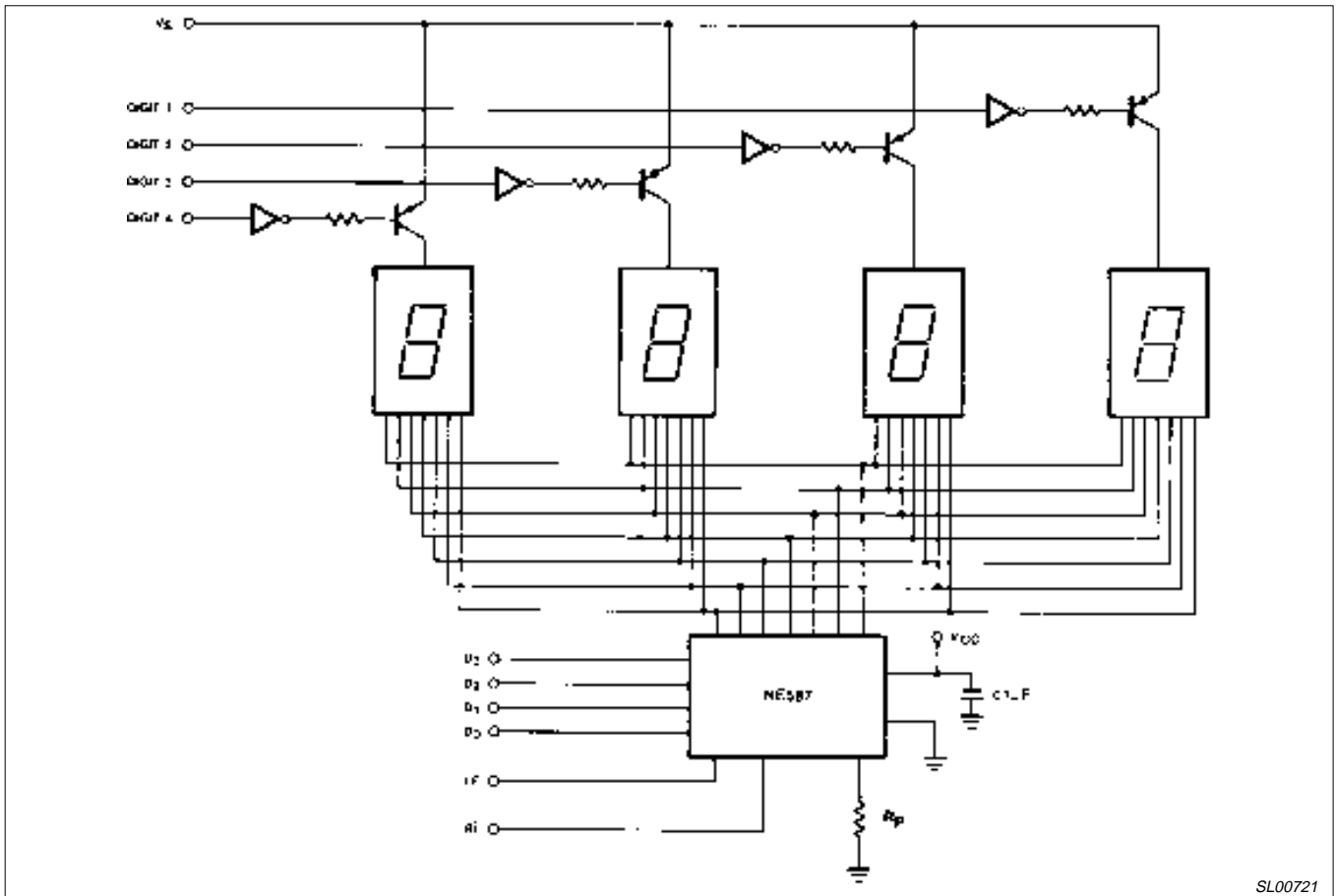

SL00721

Figure 5. 4-Digit Multiplexed LED Display

# LED decoder drivers: using the NE587

AN112

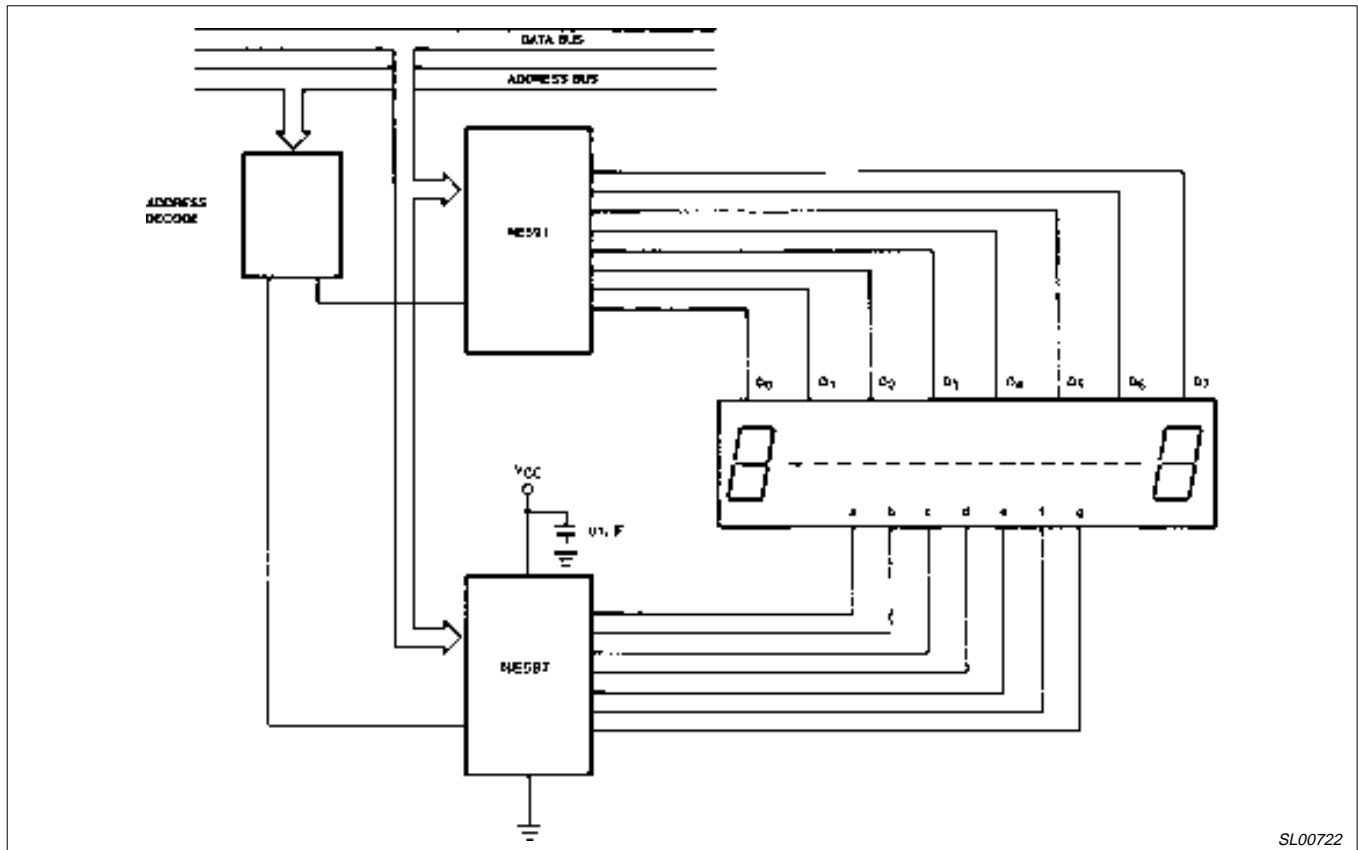

SL00722

**Figure 6. Interfacing 8-Digit LED Display With Microprocessor Bus**

Where  $V_S$  and  $V_{CC}$  are two different supplies, the  $V_S$  supply may be optimized for minimum system power dissipation and/or cost. Clearly, good regulation in the  $V_S$  supply is totally unnecessary, and so this supply can be made much cheaper than the regulated 5V supply used in the rest of the system. In fact, a simple unsmoothed full-wave rectified sine wave works extremely well if a slight loss in brightness can be tolerated. A transformer voltage of about  $3-4.5V_{RMS}$  works well in most LED display systems. Waveforms are shown in Figure 7.

The duty cycle for this system depends upon  $V_S$ ,  $V_F$  and the output characteristics of the display driver.

With  $V_S = 4.9V$  peak  
 $V_F = 2.0V$

The duty cycle is approximately 60%.

$V_S$  in this example was derived by the circuit shown in Figure 7. Remember that the forward voltage drop of the rectifying diode must be subtracted to arrive at the exact peak of the  $V_S$  voltage.

Figure 8 shows other typical application schemes for multiplexing LED displays.

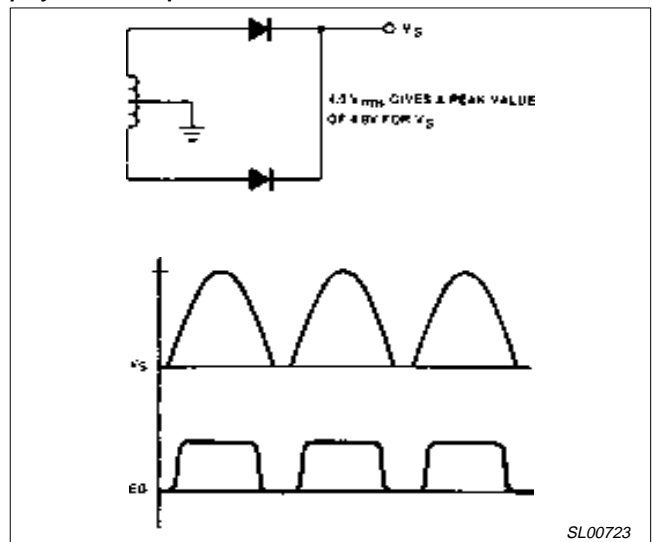

SL00723

**Figure 7.**

# LED decoder drivers: using the NE587

AN112

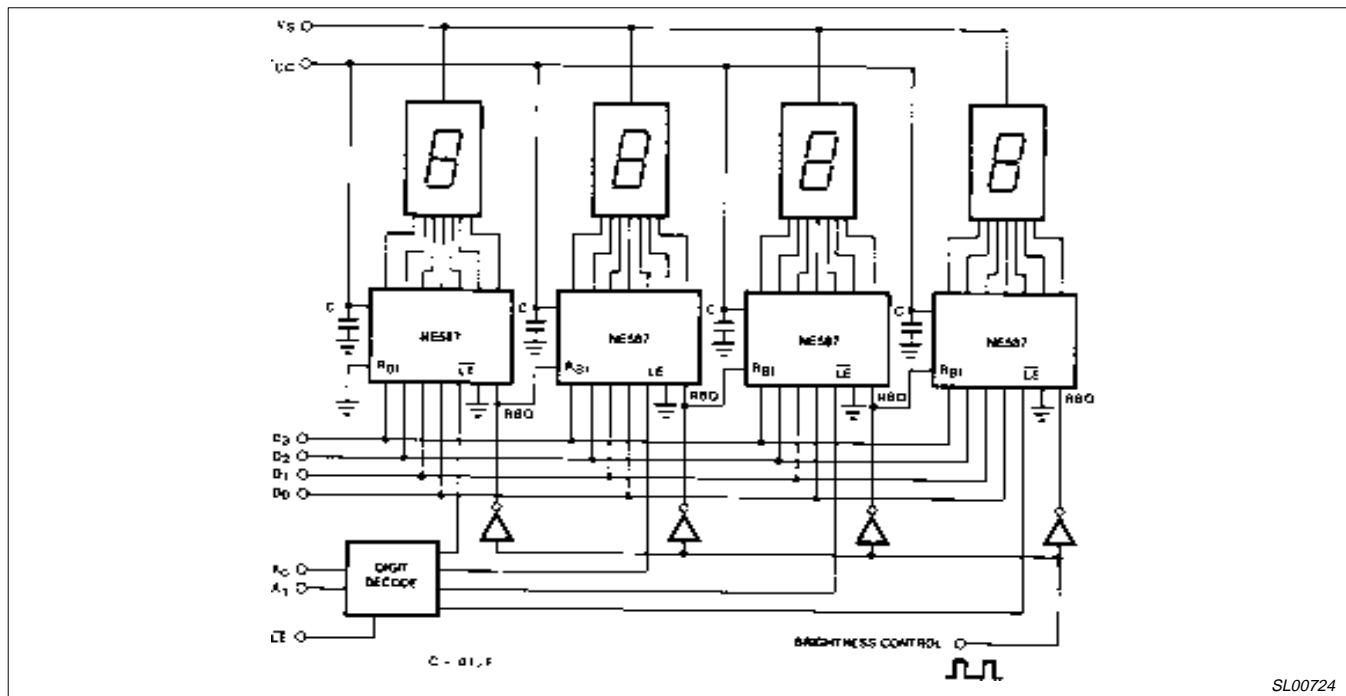

Figure 8. 4-Digit Display With Brightness Control and Leading-Edge Ripple Blanking

## ADDRESSABLE PERIPHERAL DRIVERS SUPPORT MICROPROCESSOR-BASED SYSTEMS

The Philips Semiconductors NE590, NE5090 and NE591 addressable peripheral drivers (APDs) greatly facilitate interfacing a variety of support circuits to microprocessor-based systems.

The APDs are designed to eliminate the need for many of the buffers, latches, TTL ICs, and discrete transistors currently needed to drive peripheral devices.

Figure 9 shows that each driver includes a set of input latches, a 1-of-8 demultiplexer, and a set of high current drive outputs together with the assorted chip enable and clear logic.

The low loading inputs of these drivers (typically  $I_{IL}=15\mu A$  and  $I_{IH}=1\mu A$ ) allow direct interfacing to the microprocessor bus. Eight addressable latches, which are addressed by a three bit binary code and (set/reset) by a single binary bit, allow storage of each output condition (ON/OFF), allowing the microprocessor to continue processing after the APD has been addressed.

Driver selection is accomplished with a low active chip enable which may be derived from the I/O decoder common to all I/O devices. A low active master clear is also provided to reset all outputs simultaneously. This signal may be generated from the I/O decoder or set high when not required.

The high current outputs of the drivers (250mA sinking with the NE590, 150mA sinking with the NE5090 and 250mA sourcing with the NE591) allow direct interfacing to relays, motors, lamps, LEDs, and other devices or systems requiring high current drive capabilities.

Figure 10 demonstrates the use of APDs in a microprocessor-based system. When driving LED displays, a single 8-bit word contains all the data required for defining both digit location and segment

selection. The APD uses four bits—three to address one of 8 outputs and one to set the output to an ON or OFF state.

When using the NE590 or NE5090, ON refers to the output low state in which the output is capable of sinking a maximum of 250mA for the NE590, or 150mA for the NE5090. The clear ( $\overline{CL}$ ) pin may be tied high and would normally not be required in this application.

The four remaining data bits are required by the NE587 which supplies segment data. These four BCD data bits are converted into seven-segment data used for driving the anodes of the LEDs. Data is strobed into the latches by the LATCH ENABLE INPUT at the same time that information is being supplied to the NE590. Since the NE587 provides a constant-current sink, uniform brightness is obtained from each segment in the display. The NE587 is capable of supplying up to 50mA/segment. Segment currents are set by a single programming resistor.

Figure 10 shows several devices connected to the NE591: a relay, a motor, and a D-C subsystem. Each device is selected in the same manner as the LED digits; that is, three bits are used to select the output and one bit is used to turn the output ON or OFF.

An output may be cleared in one of two ways:

- 1) By direct selection and clearing of the individual latch,
- or
- 2) By clearing all outputs through the use of the clear input.

The latter method does not require addressing.

The examples shown in Figure 10 clearly demonstrate the advantages that can be derived from using the NE590 and NE591 APDs in microprocessor-based systems. These devices provide easy interfacing and minimize the number of interfacing components; they also provide the logic interface to the microprocessor and the switch function and high current drive required by the peripheral units.

# LED decoder drivers: using the NE587

AN112

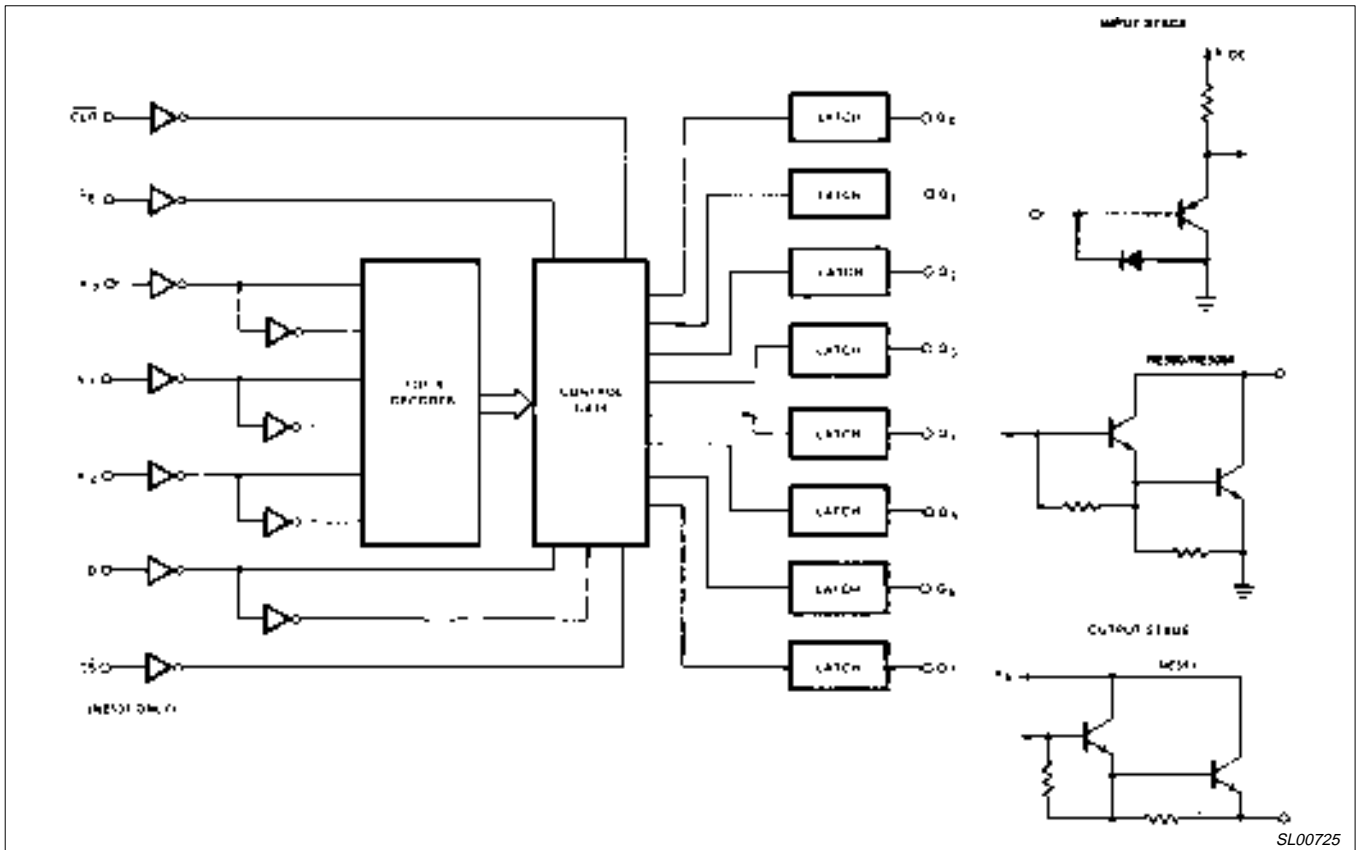

Figure 9. NE590/591/5090 Block Diagram

# LED decoder drivers: using the NE587

AN112

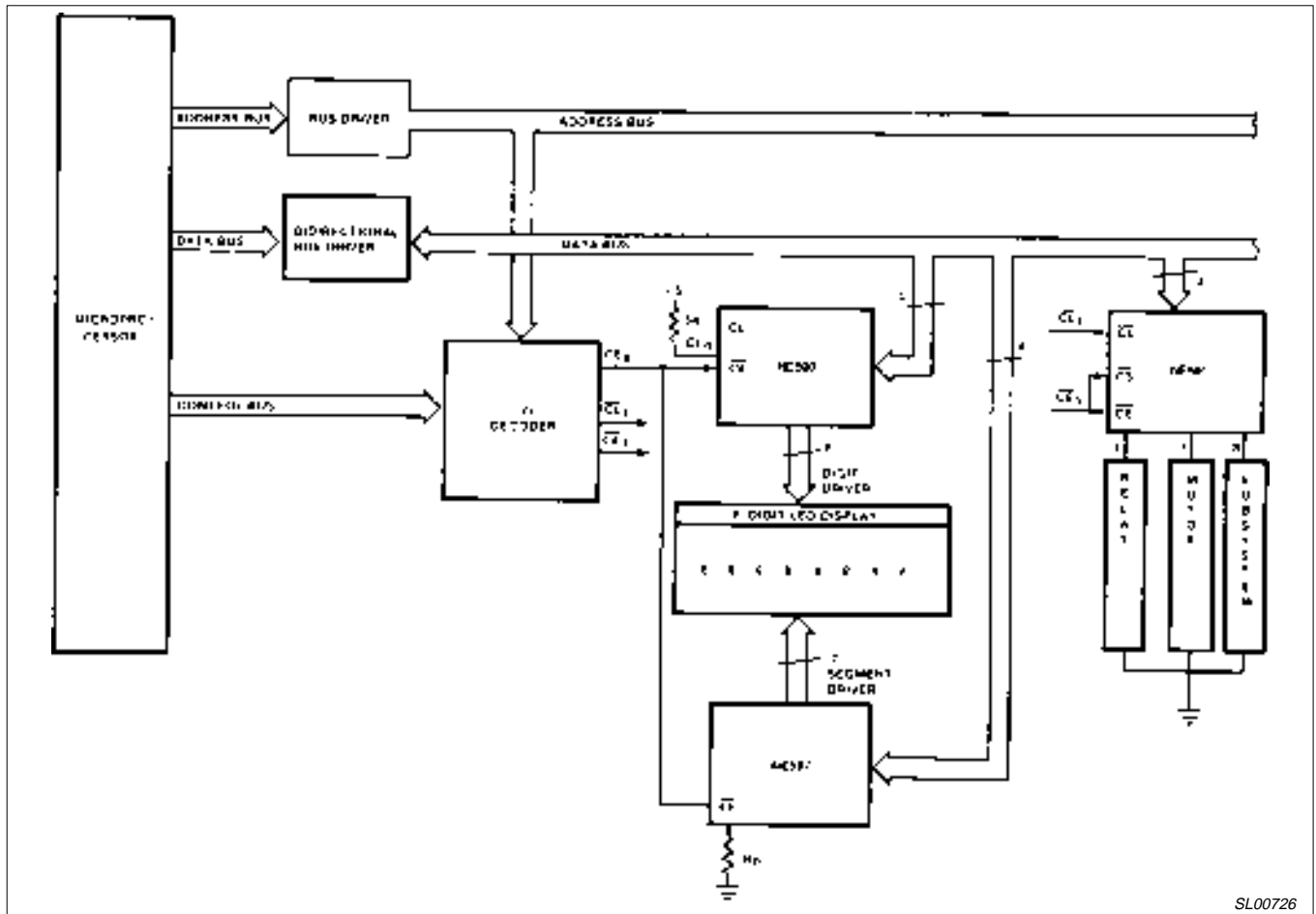

Figure 10. Microprocessor-Based System

SL00726