

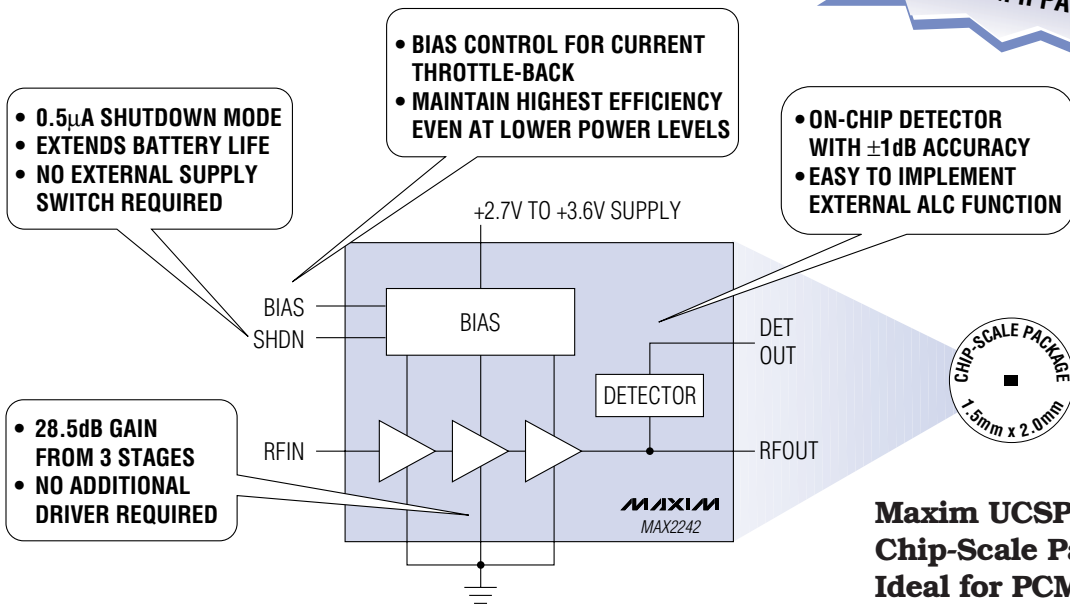

Chip-Scale PA Delivers +22.5dBm Output Power for 2.4GHz 802.11b WLAN

4.5dB
HIGHER POWER THAN
PRISM II PA!



Maxim UCSP™
Chip-Scale Package
Ideal for PCMCIA
and Compact Flash
Applications

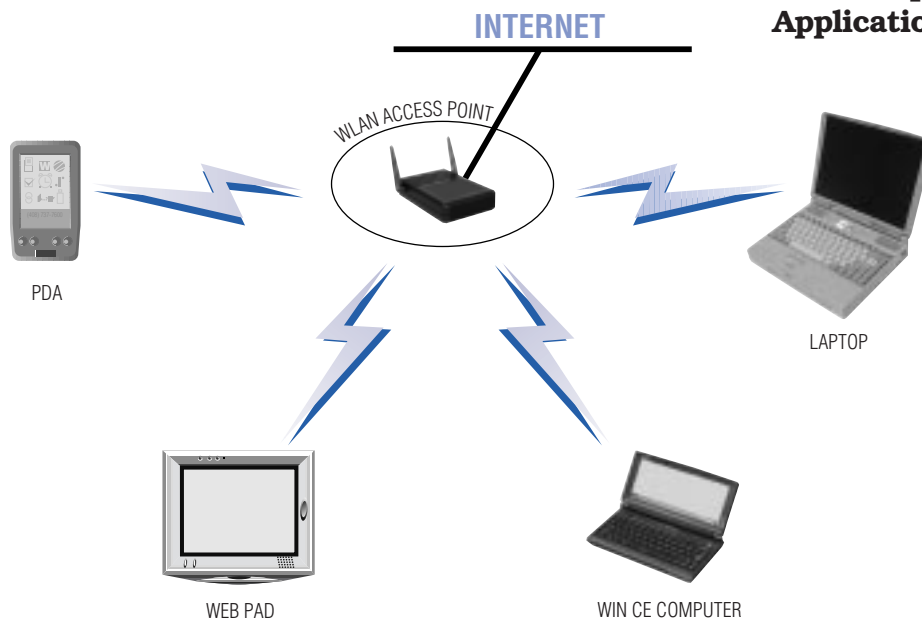

UCSP is a trademark of Maxim Integrated Products, Inc.

MAXIM is a registered trademark of Maxim Integrated Products. © 2001 Maxim Integrated Products.



Improve Bluetooth Radio Performance with Industry's Smallest LNA and PA

MAX2644 LNA Features:

- 16dB Gain, 2dB NF, -3dBm Input IP3 for 7mA
- Adjustable Bias (3mA to 10mA)
- +2.7V to +5.5V Supply
- SC70-6 Package

MAX2644 SiGe LNA

The MAX2644 2.4GHz SiGe LNA improves typical CMOS-based receiver sensitivity up to -90dBm. The LNA is internally matched to 50Ω at the output, saving an inductor and capacitor required in other LNA IC solutions. Total board space required is only 7mm²—ideal for space-sensitive Bluetooth™ modules.

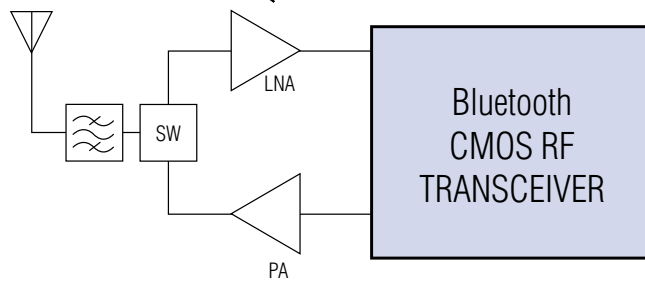

MAX2240 PA Features:

- +20dBm Output Power
- Digital Power Control
- Bluetooth Power Class 1 Compliant
- Integrated Input 50Ω Match
- 1μA Shutdown Mode

MAX2240 Chip-Scale PA

The MAX2240 2.4GHz power amplifier extends Bluetooth radio range to 100m. It is available in the 3 x 3 UCSP™, measuring only 1.56mm on a side. It occupies only 16% of the board space of the competition's 8-pin MSOP package.

UCSP BOTTOM VIEW

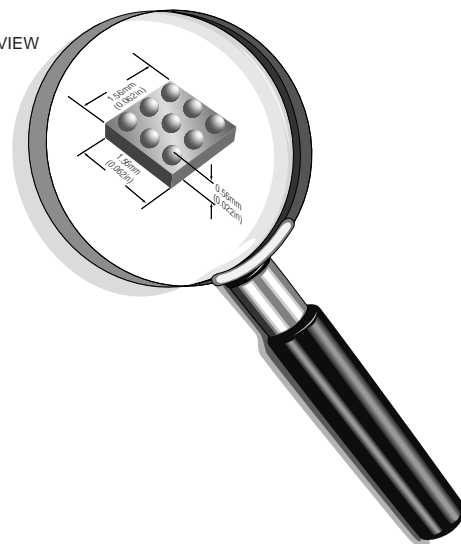

Bluetooth is a trademark of Ericsson.



5GHz Chip-Scale LNA Offers 1.8dB NF

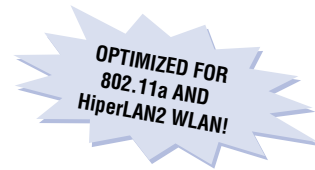

The MAX2648 SiGe LNA takes the complexity out of designing a low-cost, high-performance 5GHz LNA for IEEE802.11a and HiperLAN2 wireless LAN (WLAN) systems. Compared to a discrete design, the LNA's integrated active bias network saves one transistor and three passive components while maintaining stable RF performance over supply and temperature variations. Total board space required is only 11mm², ideal for WLAN PC cards for laptop computers.

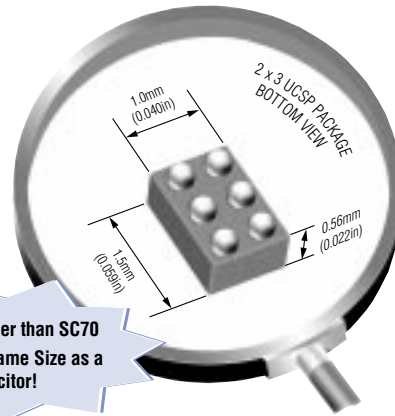
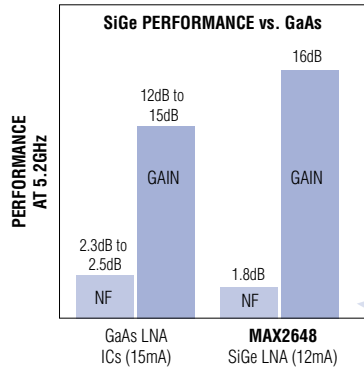

- 60% Smaller than SC70
- Virtually Same Size as a 0603 Capacitor!



Replace VCO Modules in 2.4GHz WLAN Radios with \$0.95* IC

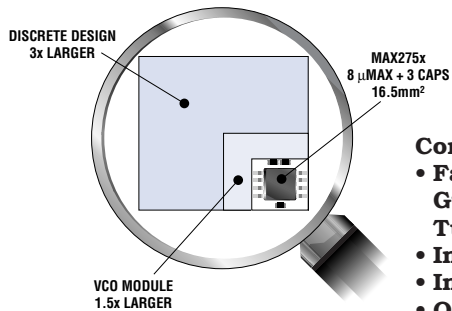

Complete Features:

- Factory-Adjusted, Guaranteed Frequency Tuning Range
- Integrated Tank Circuit
- Internally Matched Output Buffer
- On-Chip Voltage Regulator
- Logic-Controlled Shutdown

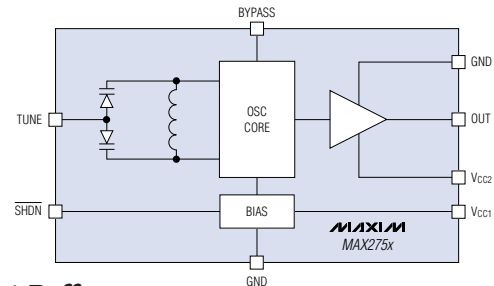

SiGe Monolithic VCOs for 2.4GHz 802.11 WLAN, HomeRF, Bluetooth, and Cordless Phones

	Part	Supply Range (V)	Guaranteed Tuning Range (MHz)	Application	Features
NEW	MAX2750	+2.7 to +5.5	2400 to 2500	Zero IF	Single-ended output
NEW	MAX2751	+2.7 to +5.5	2120 to 2260	Low-side LO, 240MHz to 280MHz IF	Single-ended output
NEW	MAX2752	+2.7 to +5.5	2025 to 2165	Low-side LO, 335MHz to 375MHz IF	Single-ended output
NEW	MAX2753	+2.7 to +5.5	2400 to 2500	Zero IF or low IF	Differential output
	MAX2754**	+2.7 to +5.5	1145 to 1250	Zero IF up to 110MHz IF (using LO doubler)	Linear modulation input for direct frequency modulation, single-ended output

*\$0.95 at 100k quantity. **Future product—contact factory for availability.



Maxim's Family of Low-Cost SiGe LNAs Covers the Entire Spectrum of Wireless Applications!

The MAX2642–MAX2645/MAX2648/MAX2651–MAX2656 LNAs are optimized for the best combination of low noise figure, high gain, and high IP3. Most feature an adjustable bias/IP3 feature, allowing the user to set the minimum required input IP3 performance required for the LNA without wasting any supply current. The adjustable bias feature also allows for flexible application of these amplifiers as: 1st or 2nd stage LNA, LO buffer, or RF gain block.

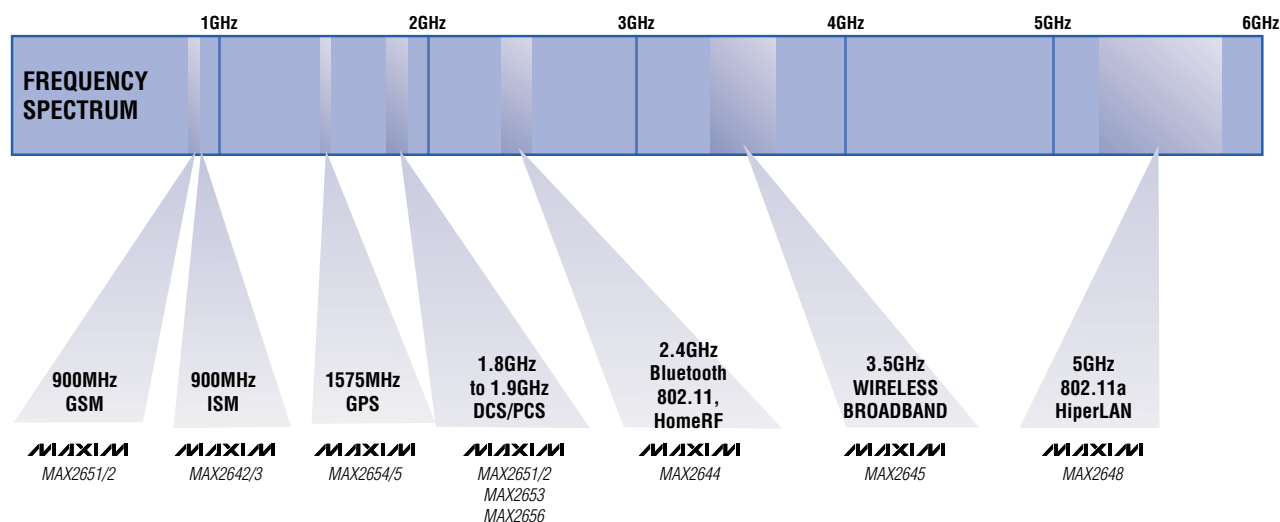

	Part	Supply Voltage (V)	Test Frequency (MHz)	Supply Current (mA)	Gain (dB)	Noise Figure (dB)	Input IP3 (dBm)	Features	Pin-Package
	MAX2642/43	+2.7 to +5.5	900	5.3	16.7	1.3	0	Adjustable IP3/bias, 13dB gain step, shutdown mode, integrated output 50Ω match	6-SC70
NEW	MAX2644	+2.7 to +5.5	2450	7.0	17	2.0	-3	Adjustable IP3/bias, shutdown mode, integrated output 50Ω match	6-SC70
	MAX2645	+3.0 to +5.5	3550	9.2	14.4	2.3	+4	Adjustable IP3/bias, 24dB gain step, shutdown mode	10-μMAX-EP
NEW	MAX2648	+2.7 to +3.6	5250	12.3	17.4	1.8	0	Chip-scale package	6-UCSP
	MAX2651	+2.7 to +3.3	945 1850	5.9 5.7	18 18	1.2 1.8	-8.5 -10	Dual LNA, 20dB gain step	10-μMAX
	MAX2652	+2.7 to +3.3	945 1850	7.2 7.0	18 18	1.3 1.8	-7.5 -7	Dual LNA, 20dB gain step, shutdown mode	10-μMAX
	MAX2653	+2.7 to +3.3	1850	5.4	18.5	1.7	-8.5	20dB gain step, shutdown mode	8-μMAX
NEW	MAX2654	+2.7 to +5.5	1575	5.8	15.1	1.5	-7.2	Shutdown mode, integrated output 50Ω match	6-SC70
NEW	MAX2655	+2.7 to +5.5	1575	8.3	14.1	1.5	+2.8	Adjustable IP3/bias, shutdown mode, integrated output 50Ω match	6-SC70
NEW	MAX2656	+2.7 to +5.5	1960	11.5	13.5	1.9	+1.5	Adjustable IP3/bias, 13dB gain step, shutdown mode, integrated output 50Ω match	6-SC70



Miniature 2GHz LNA/Mixers for W-CDMA Draw Less than 8mA Average Current

Better Performance than Discretes at Less than Half the Size

The MAX2387/MAX2388/MAX2389 were designed for the emerging ARIB (Japan) and ETSI-UMTS (Europe) wideband CDMA (W-CDMA) markets. These SiGe devices consist of a dual-gain LNA and a low-current, ultra-low-noise mixer, both optimized for 2110MHz to 2170MHz operation. The devices draw very little power from a +2.7V to +3.3V source. Their high gain and IP3 simplify meeting system noise and interference specifications, and the adjustable-gain LNA increases dynamic range while saving current. The MAX2387/MAX2388/MAX2389 support all common IF frequencies (190MHz to 380MHz). The new 12-pin leadless QFN package measures only 3mm x 3mm, saving valuable board space.

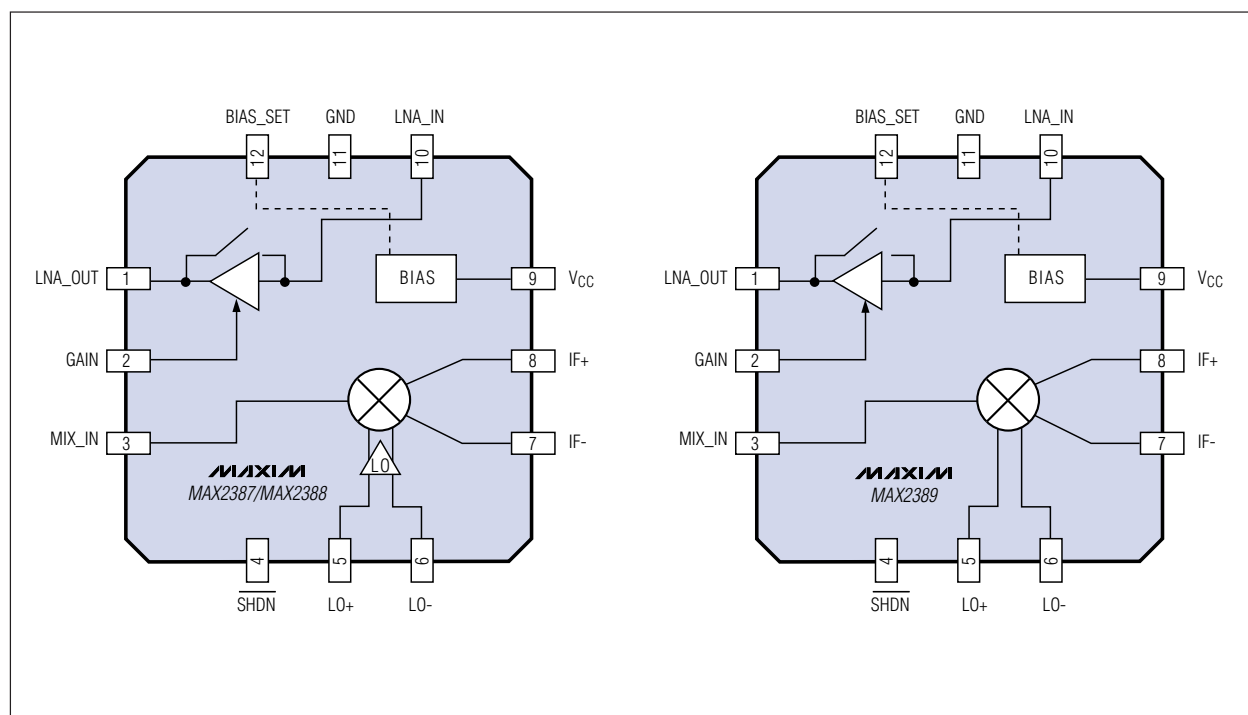

The MAX2387/MAX2388/MAX2389 come in an ultra-small 12-pin QFN package and draw an average current of less than 8mA.

Part	LO Input Power (dBm)	LNA Gain (dB)	Mixer Gain (dB)	Cascade Noise (2.5dB Filter Loss) (dB)	Supply Current (High Gain/Low Gain) (mA)
MAX2387	-10 ±3dB	15/-17	10	2.3	11/7.5
MAX2388	-10 ±3dB	15/-3	10	2.3	10/6.7
MAX2389	-4 ±3dB	15/-3	10	2.3	8/5

IP3s range from +3dBm to +6dBm for both the LNA and the mixer.



Ultra-Low-Cost Single-Supply PAs for CDMA in a Chip-Scale Package

World's Best Efficiency at Medium- to Low-Power Output in a 2.5mm x 2.5mm UCSP

The MAX2281*/MAX2282*/MAX2291* power amplifiers (PAs) are designed for use in IS-98-based CDMA, W-CDMA, UMTS, and TDMA cellular phones operating in the 800MHz and 1.9GHz ranges. They are the first PAs on the market to be packaged in a UCSP, making them ideally suited to the limited space of PCS and dual-band phone applications. They are also an excellent choice for applications in PA modules, as no wire bonding is required. The PAs deliver +29dBm (MAX2281/MAX2291) and +28dBm (MAX2282) of output power, respectively, with excellent margin over antenna specifications. The MAX2281/MAX2282/MAX2291 feature a unique architecture that yields excellent efficiency at medium and low output powers. Use Maxim's PAs if you are designing a low-cost CDMA phone with the world's best talk-time specification.

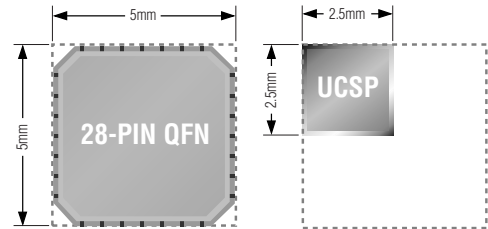

The MAX2281/MAX2291 package occupies 75% less space than a conventional 28-pin QFN.

Part	Modulation	Average Talk Current (mA)	Output Power (dBm)	Efficiency (%)	Idle Current (mA)	Gain (dB)
MAX2281	CDMA	55	29	34	35	27
MAX2282	CDMA	50	28	36	40	27
MAX2291	CDMA	55	29	34	30	27
MAX2281	TDMA	—	32	43	—	28
MAX2291	TDMA	—	31	38	—	28

Note: N-CDMA modulation.

*Future product—contact factory for availability.

MAX2281/MAX2282/MAX2292 Bottom View

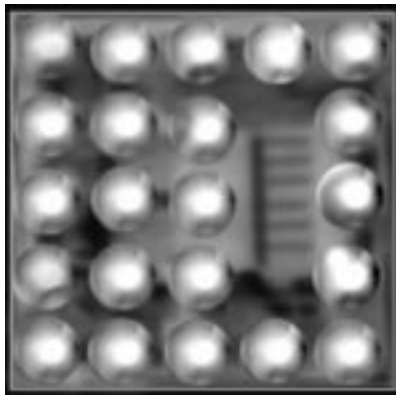

2.5mm x 2.5mm UCSP at 22x Magnification

In this bottom view of a MAX2281/MAX2282/MAX2291, 22 eutectic solder balls connect the device with the PC board. Conventional reflow methods with no underfill can be used to solder these self-aligning parts.

A UCSP application note is available upon request; please e-mail: www.RF@maximhq.com.

Build Your 45MHz to 650MHz Oscillator in 5 Minutes



STEP 1: Choose the appropriate Maxim part from the table below and calculate the inductance using the formula in the data sheet.

STEP 2: Insert inductor into EVKIT.

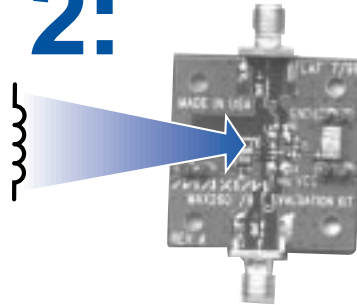

STEP 3: Test oscillation frequency. Done.

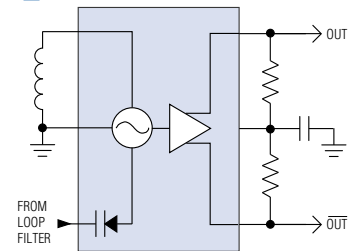

The MAX2605–MAX2609 oscillators contain varactors, core transistors, bias circuitry, coupling capacitors, and a differential output buffer in a miniature SOT23-6 package. The internal varactor's tuning range is factory tested so that startup and proper operation over temperature are guaranteed.

Part	Frequency Range (MHz)	Supply Current (mA)	Phase Noise at 100kHz Offset (dBc/Hz)
MAX2605	45 to 70	1.9	-117
MAX2606	70 to 150	2.1	-112
MAX2607	150 to 300	2.1	-107
MAX2608	300 to 500	2.7	-100
MAX2609	500 to 650	3.6	-93



Miniature Cell Phone Upconverter/Driver IC Eliminates SAW Filter, Uses Only 18mA!

UCSP IC Puts Out +6.5dBm While Measuring Only 1.5mm x 2mm

The MAX2307 is designed for Japanese N-CDMA and PDC 900MHz applications. Its unique upconverter architecture eliminates a SAW filter at the expense of just one low-cost inductor. The device is packaged in a UCSP package and draws less current than comparable discrete designs, especially at 10dB backoff from peak power, the typical CDMA output power used for talk-time calculations.

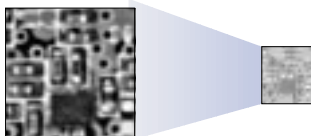
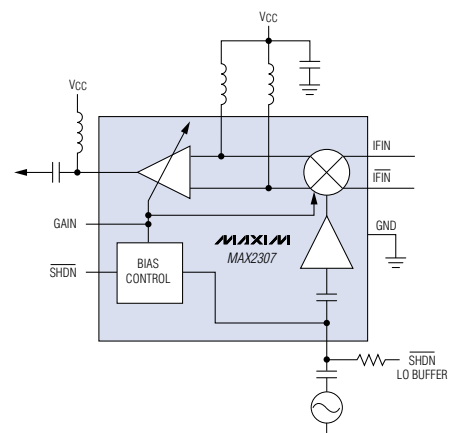

The MAX2307 saves a SAW filter and occupies only 7mm x 8mm, including all external components.

Upgraded Transmit IC for Dual-Band Cellular Phones (continued on next page)

The MAX2361*/MAX2363*/MAX2365* are functional upgrades to Maxim's popular MAX2360/MAX2362/MAX2364 series and pin-compatible upgrades to the MAX2366/MAX2367/MAX2368. They are complete transmit solutions ideal for dual-band cdmaOne™, cdma2000™, TDMA GAIT, and W-CDMA/UMTS cellular phones. For smallest transmitter implementation cost and size, they feature the industry's highest integration level. Improvements over their predecessors include lower current consumption, higher output power, lower noise, and wider dynamic range for W-CDMA. The devices accept baseband inputs to their wideband I/Q modulator with dual IF outputs. Dual IF VCOs allow different IF frequencies for PCS band and cellular band, which enables the use of a single receive IF filter. The dual-band upconverter is implemented using an image-reject architecture and is followed by up to three PA drivers. To reduce receive-band noise power in the PCS band, there are two PCS driver outputs to support split-band noise filters at no additional cost. The PA drivers' high output power allows the use of just one Tx SAW filter per band, further reducing system size and implementation cost. The MAX2361/MAX2363/MAX2365 feature over 90dB output power adjustment range through simultaneous IF and RF AGC control. The integer-N type IF and RF PLL circuits and most device operational modes are fully programmable using the 3-wire serial interface. For single-band applications, use either the MAX2363 (PCS only) or the MAX2365 (cellular only).

cdmaOne/cdma2000 Application Circuit

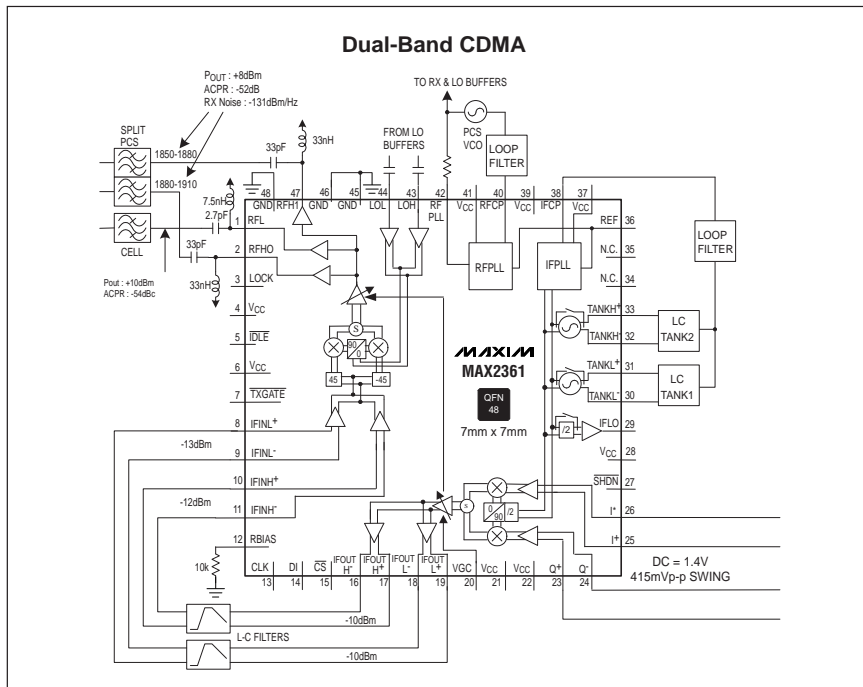

- **Dual Transmit IF Ports Support Single 186MHz Receive IF (Saves One VCO Module)**
- **Split-Band PCS Amplifiers Drive PA Directly**

* Future product—contact factory for availability.
 cdmaOne is a trademark of the CDMA Development Group.
 cdma2000 is a trademark of Telecommunications Industry Association.



Upgraded Transmit IC for Dual-Band Cellular Phones

(continued from previous page)

TDMA/GAIT Application Circuit

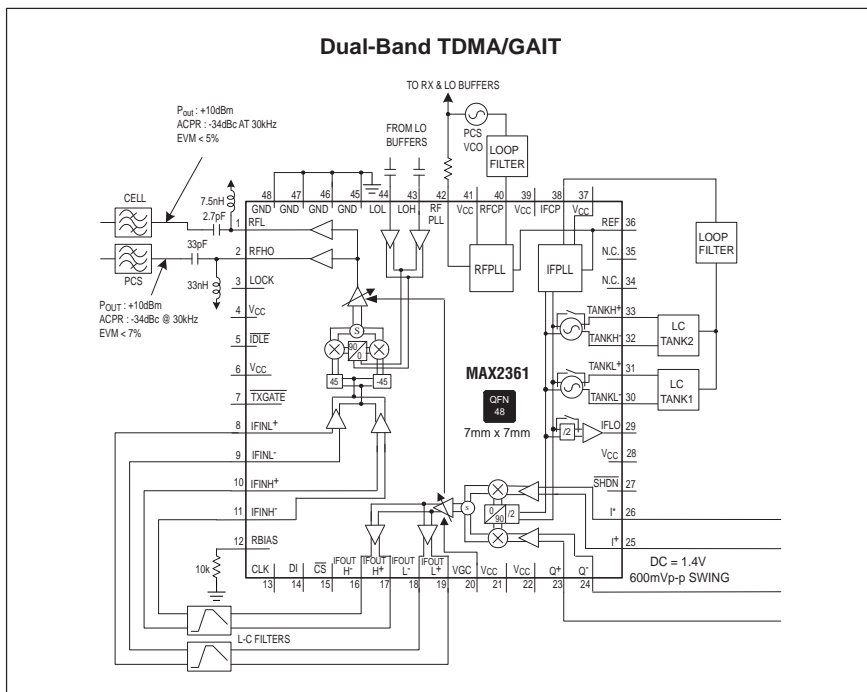

- Dual IF Ports Support Single 186MHz Receive IF (Saves One VCO Module)
- “Turbolock” on RF Synthesizer Enables Fast Switching While Maintaining <7% EVM at the Antenna
- No Expensive Fractional-N Synthesizer Needed
- No Additional Components Needed for PCS1900 Mode

W-CDMA Application Circuit

- Most Integrated W-CDMA Transmitter
- 7mm x 7mm QFN Package
- Integrated RF and IF PLLs
- Serial Interface Control
- Saves Space and Cost

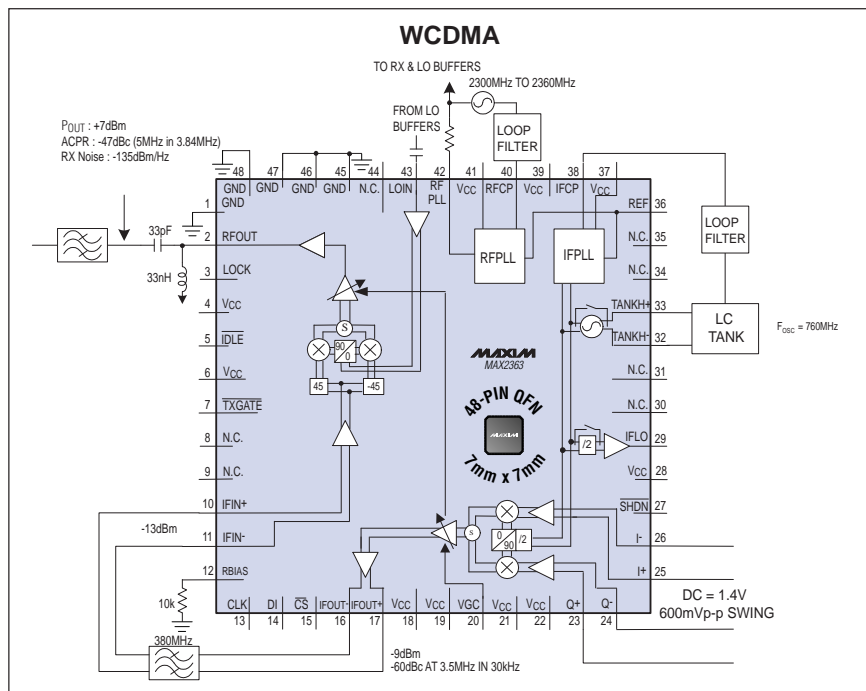

Dramatically Reduce Cost and Component Count in Your Dual-Band Cell Phone

SiGe IC replaces high component count discrete designs and eliminates one VCO module!

The MAX2338* receive RF front-end IC is designed for dual-band CDMA cellular phones, but it can also be used in dual-band TDMA, GSM, or EDGE cellular phones. Dual-band phones can now use one receive IF frequency around 183MHz. Thanks to the MAX2338's on-chip low-power LO divider, the cellular VCO module can be eliminated.

The MAX2338 represents the next generation in Maxim's comprehensive product line of cellular receive front-end ICs.

Features:

- **1.4dB LNA Noise Figure**
- **15dB LNA Gain**
- **13.5dB Mixer Gain**
- **Mixer Noise Figure**
 - **7.5dB Differential**
 - **9dB Single Ended**
- **LO Divider**
- **+11dBm Cellular LNA IIP3**
- **LO Buffer Amplifiers for Tx**
- **Ultra-Small 28-Pin QFN Package**

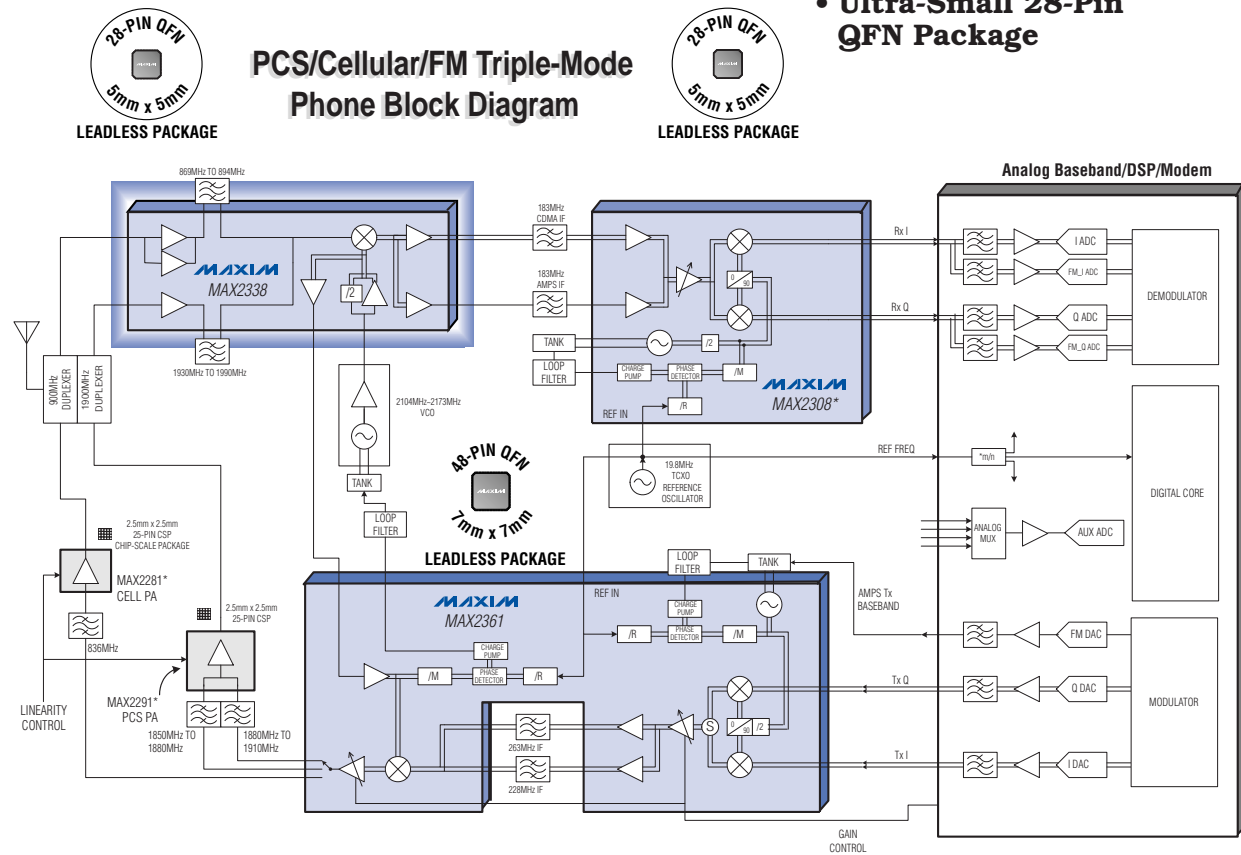

The MAX2338 simplifies the architecture of dual-band cellular radio designs, resulting in substantial size and cost reduction.

* Future product—contact factory for availability.

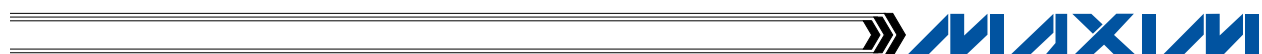

Wireless/RF Products

Part Number	Supply Voltage (V)	Input Frequency (MHz)	Input Bandwidth (MHz)	I/Q Gain Balance (dB)	I/Q Phase Balance (degrees)	AGC Range (dB)	Pins- Package	EV Kit	Features	Applications	Price [†] 25,000-up (\$)
SATELLITE RECEIVER PRODUCTS											
MAX2101	4.75 to 5.25	400 to 700	60	0.5	1.5	40	100-MQFP	Yes	I/Q demodulator with dual 5th-order Butterworth filters, 10MHz to 30MHz bandwidth, dual 6-bit ADCs	DBS, VSAT	11.49
MAX2102/5	4.75 to 5.25	950 to 2150	120	0.5(max)	3(max)	50/41	28-SO	Yes	Direct downconversion tuner IC, tunes L-band to baseband I and Q outputs	DBS, DAB, DVB	3.68**
MAX2108	4.75 to 5.25	950 to 2150	150	1(max)	3(max)	50	24-SSOP	Yes	Direct downconversion tuner with divide by 32/33 prescaler	DBS, DAB	3.68**
MAX2740	2.7 to 3.3	-	-	-	-	-	48-TQFP-EP	Yes	Complete GPS receiver	GPS	††

Part Number	Supply Voltage (V)	Supply Current (mA)	IF Frequency (MHz)	I/Q Bandwidth (MHz)	AGC Range (dB)	Sideband Suppression (dBC)	Pins- Package	EV Kit	Features	Applications	Price [†] 1000-up (\$)
MODULATORS AND DEMODULATORS											
MAX2308	2.7 to 5.5	26	40 to 300	5	110	-35	28-QFN	Yes	Dual-mode AGC + I/Q converter	Triple-mode CDMA cellular phones, W-CDMA cellular phones	††
MAX2309	2.7 to 5.5	26	40 to 300	5	110	-35	28-QFN	Yes	Dual-mode AGC + I/Q converter with LO O/P buffer	Triple-mode CDMA cellular phones, W-CDMA cellular phones	††
MAX2310	2.7 to 5.5	26	40 to 300/70 to 300	5	110	-35	28-QSOP	Yes	Dual-mode/dual-band, 110dB IF AGC + I/Q converter with 2 VCOs and synthesizer	CDMA cellular phones, W-CDMA cellular phones, wireless local loop	4.80
MAX2312	2.7 to 5.5	26	70 to 300	5	110	-35	28-QSOP	Yes	110dB IF AGC + I/Q converter with VCO and synthesizers	CDMA cellular phones, W-CDMA cellular phones, wireless local loop	4.35
MAX2314	2.7 to 5.5	26	40 to 150/40 to 300	5	110	-35	28-QSOP	Yes	Dual-mode, 110dB IF AGC + I/Q converter with VCO and synthesizer	CDMA cellular phones, W-CDMA cellular phones, wireless local loop	4.35
MAX2316	2.7 to 5.5	26	40 to 150	5	110	-35	28-QSOP	Yes	110dB IF AGC + I/Q converter with VCO and synthesizer	CDMA cellular phones, W-CDMA cellular phones, wireless local loop	4.35
MAX2450	2.7 to 3.3	5.9	35 to 80	9	-	-38	20-SO/QSOP	Yes	70MHz I/Q modulator/demodulator with on-chip VCO and quad generator, shutdown mode	Cellular, ISM, WLANs	3.99
MAX2451	2.7 to 3.3	5.5	35 to 80	9	-	-	16-SO	Yes	70MHz I/Q demodulator with on-chip VCO and quad generator, shutdown mode	Cellular, ISM, WLANs	3.23
MAX2452	2.7 to 3.3	4.1	35 to 80	15	-	-42	16-SO	Yes	70MHz I/Q modulator with on-chip VCO and quad generator, shutdown mode	Cellular, ISM, WLANs	3.23

Part Number	Supply Voltage (V)	Receive Input IP3 (dBm)	Transmit Output P _{1dB} (dBm)	RF Frequency (MHz typ)	IF Frequency (MHz typ)	Pins- Package	EV Kit	Features	Applications	Price [†] 1000-up (\$)
TRANSCIEVERS										
MAX2410	2.7 to 5.5	-12.5	+6	1900	45 to 450	28-QSOP	Yes	Low-noise amplifier and Rx mixer with high IP3, low-noise Tx mixer and variable-gain PA driver (separate IF ports)	PCS and cellular phones	3.47
MAX2411A	2.7 to 5.5	-12.5	+6	1900	45 to 450	28-QSOP	Yes	Low-noise amplifier and Rx mixer with high IP3, low-noise Tx mixer and variable-gain PA driver (common IF ports)	PCS and cellular phones	3.47

† Prices provided are for design guidance and are FOB USA. International prices will differ due to local duties, taxes, and exchange rates. Not all packages are offered in 1k increments, and some may require minimum order quantities.

** 2500 pc. factory-direct price, FOB USA. Factory-direct orders are accepted only in multiples of 2500 or 10,000 pieces (smaller quantities are available from distributors).

Wireless/RF Products (continued)

Part Number	Supply Voltage (V)	Receive Input IP3 (dBm)	Transmit Output P _{1dB} (dBm)	RF Frequency (MHz typ)	IF Frequency (MHz typ)	Pins- Package	EV Kit	Features	Applications	Price [†] 1000-up (\$)		
TRANSCEIVERS (continued)												
MAX2420/1/2	2.7 to 4.8	-17/-8/+2*	+2	800 to 1000	10.7/46/70	28-SSOP	Yes	Image-reject up/downconverter, VCO, prescaler, 30dB transmit VGA, programmable-gain LNA and 0dBm PA predriver, high-side LO injection	Cordless phones, cellular phones, ISM spread spectrum, RF transceivers	2.75		
MAX2424/6	2.7 to 4.8	-17/-8/+2*	0	800 to 1000	10.7/70	28-SSOP	Yes	Image-reject downconverter, VCO, prescaler, balanced transmit modulator, programmable-gain LNA and -3dBm PA predriver, high-side LO injection	Cordless phones, ISM spread spectrum, RF transceivers	2.65		
MAX2460/3	2.7 to 4.8	-17/-8/+2*	+2	800 to 1000	10.7/110	28-SSOP	Yes	Same as MAX242X series except for low-side LO injection	Cordless phones, ISM spread spectrum, RF transceivers	2.75		
LNA + MIXERS												
Part Number	Supply Voltage (V)	Supply Current (mA)	LNA IIP3 (dBm)	Mixer IIP3 (dBm)	RF Frequency (MHz)	IF Frequency (MHz)	Pins- Package	Cascade NF (dB)	EV Kit	Features	Applications	Price [†] 1000-up (\$)
MAX2320	2.7 to 3.6	Adj (20/17/14)	+9/+4/+15	+4/+1.5	1800 to 2500/800 to 1000	50 to 400	20-TSSOP-EP	2.6	Yes	Switched-gain LNAs, PCS and cellular bands, dual IF outputs and LO inputs, VCO buffer	Dual-band and triple-mode cellular phones	3.75
MAX2321	2.7 to 3.6	Adj (20/17/14)	+9/+4/+15	+4/+2	1800 to 2500/800 to 1000	50 to 400	20-TSSOP-EP	2.9	Yes	Switched-gain LNAs, PCS and cellular bands, dual IF outputs, on-chip LO doubler, VCO buffer	Dual-band and triple-mode cellular phones	4.05
MAX2322	2.7 to 3.6	Adj (20/17/14)	+9/+4/+5	+4/+1.5	1800 to 2500	50 to 400	20-TSSOP-EP	2.6	Yes	Switched-gain LNA, PCS band, VCO buffer, selectable LO doubler	PCS cellular phones	3.00
MAX2323	2.7 to 3.6	Adj (26/17/16)	+11/+5/+17	+4.5	1800 to 2500/800 to 1000	50 to 400	28-QFN	2.6	Yes	Switched-gain LNAs, has 3-states in cellular band, has 2-states in PCS band, dual IF outputs and LO inputs	Dual-band and triple-mode cellular phones	3.51
MAX2324	2.7 to 3.6	Adj (20/17/14)	+9/+4/+16	+4/+1.5	800 to 1000	50 to 400	20-TSSOP-EP	2.3	Yes	Switched-gain LNA, cellular band, dual IF outputs, VCO buffer	Dual-mode cellular phones	3.00
MAX2325	2.7 to 3.6	Adj (26/17/16)	+11/+5/+17	+4.5	800 to 1000	50 to 400	28-QFN	2.3	Yes	3 LNA states, dual IF output	Dual-mode cellular phones	2.94
MAX2326	2.7 to 3.6	Adj (20/17/14)	+9/+4/+15	+4/+1.5	1800 to 2500/800 to 1000	50 to 400	20-TSSOP-EP	2.6	Yes	Switched-gain LNAs, PCS and cellular bands, dual IF outputs, on-chip LO divide-by-2, VCO buffer	Dual-band and triple-mode cellular phones	4.05
MAX2327	2.7 to 3.6	Adj	+2/+3.5	+1.5/+1.5/+5.5	1800 to 2500/800 to 1000	50 to 400	20-TSSOP-EP	2.74	Yes	MAX2320 with independently controllable VCO buffer	Dual-band and triple-mode cellular phones	3.75
MAX2338	2.7 to 3.3	Adj (26/16/13.5)	+12/+5/+18	+5/+2.5	1930 to 1990/869 to 894	50 to 400	28-QFN	2.4	Yes	Switched-gain LNAs, PCS and cellular bands, dual IF outputs, on-chip LO divide-by-2, VCO buffer	Dual-band and triple-mode cellular phones	3.51
MAX2387	2.5 to 3.3	11/7.5	+3	+6	2110 to 2170	150 to 400	12-QFN	2.3	Yes	Switched-gain LNA w/30dB step, -10dBm LO input	W-CDMA cellular phones, UMTS phones	2.25
MAX2388	2.5 to 3.3	10.5/7.5	+3	+5	2110 to 2170	150 to 400	12-QFN	2.3	Yes	Switched-gain LNA w/20dB step, -10dBm LO input	W-CDMA cellular phones, UMTS phones	2.25
MAX2389	2.5 to 3.3	8.5/5	+3	+5	2110 to 2170	150 to 400	12-QFN	2.3	Yes	Switched-gain LNA w/20dB step, -4dBm LO input	W-CDMA cellular phones, UMTS phones	2.25

* LNA in low-gain setting.

† Prices provided are for design guidance and are FOB USA. International prices will differ due to local duties, taxes, and exchange rates. Not all packages are offered in 1k increments, and some may require minimum order quantities.

Wireless/RF Products (continued)

Part Number	Supply Voltage (V)	Supply Current (mA)	RF Frequency (MHz)	IF Frequency (MHz)	Cascaded NF (dB)	Cascaded Gain (dB)	Cascaded IP3 (dBm)	Pins- Package	EV Kit	Features	Applications	Price† 1000-up (\$)
LNA + MIXERS (continued)												
MAX2406	2.7 to 5.5	20	-9.5	+4.5	1900 (typ)	45 to 450	20-QSOP	3.2	Yes	Low-noise amplifier and high input IP3 mixer	PCS and cellular phones	2.38
MAX2440	2.7 to 4.8	23	800 to 1000	10	4	22	-17/+2*	28-SSOP	Yes	Image-reject downconverter, VCO, prescaler, programmable-gain LNA, high-side LO injection	Cordless phones, ISM spread spectrum, wireless data	2.25
MAX2441	2.7 to 4.8	23	800 to 1000	46	4	22	-17/+2*	28-SSOP	Yes	Image-reject downconverter, VCO, prescaler, programmable-gain LNA, high-side LO injection	Cordless phones, ISM spread spectrum, wireless data	2.25
MAX2442	2.7 to 4.8	23	800 to 1000	70	4	21	-17/+2*	28-SSOP	Yes	Image-reject downconverter, VCO prescaler, programmable-gain LNA, high-side LO injection	Cordless phones, ISM spread spectrum, wireless data	2.25
MAX2685	2.7 to 5.5	8.4	800 to 1000	80	2.97	21.1	-9.5/+9.5*	16-QSOP	Yes	LNA bypass switch, LO buffer, differential IF output	IS-136 TDMA phones, cordless phones, 868/900MHz ISM, wireless data	1.37

Part Number	Supply Voltage (V)	Supply Current (mA)	Gain (dB)	Transmit Output (dBm)	RF Frequency (MHz)	IF Frequency (MHz)	Pins- Package	EV Kit	Features	Applications	Price† 1000-up (\$)
UPCONVERTERS/DRIVERS											
MAX2307	2.8 to 4.2	33.5 (+6.5dBm) 15 (-15dBm)	-10 to +24.5	+6.5 (-55dBc ACFR)	900	150	11-UCSP	Yes	Miniature upconverter/driver does not require SAW filter	CDMA, PDC cellular phones	1.44
MAX2381	2.7 to 3.0	37 (+6dBm)	-10 to +22	+6 (-43dBc ACFR)	1950	380	11-UCSP	Yes	Miniature low-current upconverter/driver, 380MHz IF	W-CDMA, PDC cellular phones	††
MAX2382	2.7 to 3.0	37 (+6dBm)	-10 to +22	+6 (-43dBc ACFR)	1950	500	11-UCSP	Yes	Miniature low-current upconverter/driver, 500MHz IF	W-CDMA, PDC cellular phones	††

Part Number	Supply Voltage (V)	Receive Input IP3 (dBm)	Transmit Output P1dB (dBm)	RF Frequency (MHz)	IF Frequency (MHz)	Pins- Package	EV Kit	Features	Applications	Price† 1000-up (\$)
UPCONVERTERS AND DOWNCONVERTERS										
MAX2660	2.7 to 5.5	5.9(OIP3)	-8.4	400 to 2500	40 to 500	6-SOT23	Yes	Low-noise, low-voltage upconverter, 5mA supply current, 1µA shutdown	Hand-held receivers, WLANs, ISM, PCS, portable phones	0.76**
MAX2661	2.7 to 5.5	7.1(OIP3)	-6	400 to 2500	40 to 500	6-SOT23	Yes	Low-noise, low-voltage upconverter, 9mA supply current, 1µA shutdown	Hand-held receivers, WLANs, ISM, PCS, portable phones	0.76**
MAX2663	2.7 to 5.5	0.7(OIP3)	-12.3	400 to 2500	40 to 500	6-SOT23	Yes	Low-noise, low-voltage upconverter, 3mA supply current, 1µA shutdown	Hand-held receivers, WLANs, ISM, PCS, portable phones	0.76**
MAX2671	2.7 to 5.5	9.6(OIP3)	-5.5	400 to 2500	40 to 500	6-SOT23	Yes	Low-noise, low-voltage upconverter, 12mA supply current, 1µA shutdown, buffered LO	Hand-held receivers, WLANs, ISM, PCS, portable phones	0.76**
MAX2673	2.7 to 5.5	7.6(OIP3)	-2.1	400 to 2500	40 to 500	8-µMAX	Yes	Low-noise, low-voltage upconverter, 20mA supply current, 1µA shutdown, differential inputs	Hand-held receivers, WLANs, ISM, PCS, portable phones	0.95

* LNA in low-gain setting.

† Prices provided are for design guidance and are FOB USA. International prices will differ due to local duties, taxes, and exchange rates. Not all packages are offered in 1k increments, and some may require minimum order quantities.

** 2500 pc. factory-direct price, FOB USA. Factory-direct orders are accepted only in multiples of 2500 or 10,000 pieces (smaller quantities are available from distributors).

Wireless/RF Products (continued)

Part Number	Supply Voltage (V)	Receive Input IP3 (dBm)	Transmit Output P1dB (dBm)	RF Frequency (MHz)	IF Frequency (MHz)	Pins-Package	EV Kit	Features	Applications	Price† 1000-up (\$)
UPCONVERTERS AND DOWNCONVERTERS (continued)										
MAX2680/1/2	2.7 to 5.5	-7/+1/+3	-	400 to 2500	10 to 500	6-SOT23	Yes	SiGe low-noise, high IP3 downconverter, 5/9/15mA supply current, 1µA shutdown	Hand-held receivers, WLANs, ISM, PCS, portable phones	0.92**
MAX2683	2.7 to 5.5	7 to 11	-	3400 to 3800	100 to 400	16-TSSOP-EP	Yes	SiGe technology, programmable IP3, selectable LO doubler	WLL, wireless broadband access, microwave radios	1.90
MAX2684	2.7 to 5.5	8 to 12	-	3400 to 3800	800 to 1000	16-TSSOP-EP	Yes	SiGe technology, programmable IP3, selectable LO doubler	WLL, wireless broadband access, microwave radios	1.90
MAX2690	2.7 to 5.5	7.6	-	400 to 2500	10 to 500	10-µMAX	Yes	Low-noise, 10dB NF, low-voltage downconverter, 15mA supply current, 1µA shutdown, differential IF port	Hand-held receivers, WLANs, ISM, PCS, portable phones	1.98
TRANSMITTERS AND POWER AMPLIFIERS										
MAX2232/3	2.7 to 5.5	800 to 1000	250	24/18	E	16-PwrQSOP	Yes	3.6V, 250mW power amplifier, programmable on/off ramp control, analog/digital gain control, shutdown mode, standby mode	Digital cordless, 868/900MHz ISM-band radios, wireless data	1.94
MAX2235	2.7 to 5.5	800 to 1000	1W	37	C	20-TSSOP-EP	Yes	3V, 1W power amplifier, power on/off ramp control, gain control, shutdown mode	Digital cordless, 868/900MHz ISM-band radios, two-way pagers	2.07
MAX2240	2.7 to 5	2400 to 2500	19dBm	Digital 4 levels	C	9-UCSP	Yes	Optimized for Bluetooth Class I, digital power control, shutdown mode	Bluetooth 802.11 FH, 2.4GHz ISM	1.75
MAX2242	2.7 to 3.6	2400 to 2500	22.5dBm	-	A	12-UCSP	Yes	Optimized for 802.11b WLAN, on-chip power detector, bias control, shutdown mode	802.11b WLAN, HomeRF, 2.4GHz cordless, 2.4GHz ISM	1.97
MAX2251	2.7 to 5	824 to 849	30.3dBm	-	AB	16-CSP	Yes	Ultra-low cost and smallest size	TDMA cellular and dual-band phones	††
MAX2264	2.7 to 5	824 to 849	28dBm	-	AB	16-TSSOP-EP	Yes	Single-supply, dual-mode linear PA	CDMA dual-mode cellular phones	3.86
MAX2265	2.7 to 5	824 to 849	28dBm	-	AB	16-TSSOP-EP	Yes	Single-supply, dual-mode linear PA with 37% CDMA efficiency	CDMA and TDMA dual-mode cellular phones	3.86
MAX2266	2.7 to 5	824 to 849	28dBm	-	AB	16-TSSOP-EP	Yes	Single-supply, dual-mode linear PA with world's best efficiency at +16dBm	CDMA dual-mode cellular phones	3.86
MAX2267	2.7 to 5	887 to 925	27dBm	-	AB	16-TSSOP-EP	Yes	MAX2264 optimized for Japanese cellular band and 27dBm output power	CDMA dual-mode cellular phones	3.86
MAX2268	2.7 to 5	887 to 925	27dBm	-	AB	16-TSSOP-EP	Yes	MAX2265 optimized for Japanese cellular band and 27dBm output power	CDMA dual-mode cellular phones	3.86
MAX2269	2.7 to 5	887 to 925	27dBm	-	AB	16-TSSOP-EP	Yes	MAX2266 optimized for Japanese cellular band and 27dBm output power	CDMA dual-mode cellular phones	3.86
MAX2281	2.7 to 5	824 to 849	29.5dBm	-	AB	22-UCSP	Yes	Ultra-low-cost PA with very low idle current	Optimized for cellular U.S.-CDMA/TDMA	††
MAX2282	2.7 to 5	887 to 925	28dBm	-	AB	22-UCSP	Yes	Ultra-low-cost PA with very low idle current	Optimized for Japanese CDMA	††
MAX2291	2.7 to 5	1850 to 1910	29.5dBm	-	AB	22-UCSP	Yes	Ultra-low-cost PA with very low idle current	Optimized for U.S.-PCS CDMA/TDMA	††
MAX2402	4.75 to 5.5	800 to 1000	100	40	AB to B, Adj.	20-SSOP	Yes	Power amplifier with balanced modulator, linear modulation to 2V, shutdown mode	ISM spread spectrum, DS, FH, BPSK, ASK, FSK	2.40

† Prices provided are for design guidance and are FOB USA. International prices will differ due to local duties, taxes, and exchange rates. Not all packages are offered in 1k increments, and some may require minimum order quantities.

†† Future product—contact factory for pricing and availability. Specifications are preliminary.

Wireless/RF Products (continued)

Part Number	Supply Voltage (V)	Frequency Range (MHz)	Output Power (mW)	Power Control (dB)	Class	Pins- Package	EV Kit	Features	Applications	Price† 1000-up (\$)
TRANSMITTERS AND POWER AMPLIFIERS (continued)										
MAX2430	3 to 5.5	800 to 1000	125 (at 3.6V)	15	AB	16-SO/ PwrQ SOP	Yes	True single-supply power amplifier, power on/off ramp control, more than 32dB gain, shutdown mode	900MHz cordless phones, ISM-band spread spectrum	1.50
MAX2601	2.7 to 5.5	DC to >1000	1W	-	AB/C	8-SO	Yes	3.6V, 1W power transistor in a thermally enhanced plastic package	AMPS phones, two-way paging, CDPD, ISM-band radios	1.75
MAX2602	2.7 to 5.5	DC to >1000	1W	-	AB/C	8-SO	Yes	3.6V, 1W power transistor with an on-chip thermally matched bias diode	AMPS phones, two-way paging, CDPD, ISM-band radios	1.75

Part Number	Supply Voltage (V)	IF Frequency 1st/2nd (MHz)	RSSI Range (dB)	Tx Power Control (dB)	Image- Reject Mixers	EV Kit	Features	Applications	Price† 1000-up (\$)	
INTERMEDIATE-FREQUENCY PRODUCTS										
MAX2510	2.7 to 5.5	100 to 600/ 1 to 30	>90	40	No	Yes	IF transceiver with downconverter mixer, limiting amplifier, transmit I/Q mixers, and VGA	PCS phones (PWT1900, PACS, PHS), wireless local loop, RF transceivers	5.35	
MAX2511	2.7 to 5.5	200 to 440/ 8 to 13	>90	40	Yes	Yes	IF transceiver with image-reject downconverter, limiting amplifier, transmit image-reject mixer, and VGA	PCS phones (PWT1900, PACS, PHS), wireless local loop, RF transceivers	5.94	

Part Number	Supply Voltage (V)	Frequency Range (MHz)	Supply Current (mA)	Phase Noise (dBc/Hz)	Output Power (dBm)	Pins- Package	EV Kit	Features	Applications	Price† 1000-up (\$)
OSCILLATORS										
MAX2605	2.7 to 5.5	45 to 70	1.9	-117	-10	6-SOT	Yes	Few external components, easy to use	Cellular and cordless phones, communication systems	0.90
MAX2606	2.7 to 5.5	70 to 150	2.1	-112	-10	6-SOT	Yes	Few external components, easy to use	Cellular and cordless phones, communication systems	0.90
MAX2607	2.7 to 5.5	150 to 300	2.1	-107	-10	6-SOT	Yes	Few external components, easy to use	Cellular and cordless phones, communication systems	0.90
MAX2608	2.7 to 5.5	300 to 500	2.7	-100	-10	6-SOT	Yes	Few external components, easy to use	Cellular and cordless phones, communication systems	0.90
MAX2620	2.7 to 5.25	10 to 1050	9	-110 (at 25kHz offset from 900MHz carrier)	-3 (2 outputs), 0 (differential)	8-µMAX	Yes	Low voltage, lowest phase noise, dual outputs, superior isolation	Digital and analog cellular and cordless phones, PCS, pagers, ISM-band radios	1.04
MAX2622	2.7 to 3.6	855 to 881	9.5	-100 (at 100kHz offset)	-8	8-µMAX	Yes	Fully monolithic VCO with a single output and shutdown	ISM-band radios	1.80
MAX2623	2.7 to 3.6	855 to 950	9.5	-100 (at 100kHz offset)	-8	8-µMAX	Yes	Fully monolithic VCO with a single output and shutdown	DECT, ISM-band radios	1.80
MAX2624	2.7 to 3.6	947 to 998	9.5	-100 (at 100kHz offset)	-8	8-µMAX	Yes	Fully monolithic VCO with a single output and shutdown	ISM-band radios	1.80

† Prices provided are for design guidance and are FOB USA. International prices will differ due to local duties, taxes, and exchange rates. Not all packages are offered in 1k increments, and some may require minimum order quantities.

‡ Future product—contact factory for pricing and availability. Specifications are preliminary.

** 2500 pc. factory-direct price, FOB USA. Factory-direct orders are accepted only in multiples of 2500 or 10,000 pieces (smaller quantities are available from distributors).

Wireless/RF Products (continued)

Part Number	Supply Voltage (V)	Frequency Range (MHz)	Supply Current (mA)	Phase Noise (dBc/Hz)	Output Power (dBm)	Pins- Package	EV Kit	Features	Applications	Price† 1000-up (\$)
OSCILLATORS (continued)										
MAX2750	2.7 to 5.5	2400 to 2500	11.3	-98 at 100kHz offset	-3	8-µMAX	Yes	Guaranteed frequency tuning range, integrated tank, shutdown mode	802.11, HomeRF, Bluetooth, cordless, 2.4GHz ISM	1.78
MAX2751	2.7 to 5.5	2120 to 2260	9.7	-93 at 100kHz offset	-3	8-µMAX	Yes	Guaranteed frequency tuning range, integrated tank, shutdown mode	802.11, HomeRF, Bluetooth, cordless, 2.4GHz ISM	1.78
MAX2752	2.7 to 5.5	2025 to 2165	10	-93 at 100kHz offset	-3	8-µMAX	Yes	Guaranteed frequency tuning range, integrated tank, shutdown mode	802.11, HomeRF, Bluetooth, cordless, 2.4GHz ISM	1.78
MAX2753	2.7 to 5.5	2400 to 2500	8.6	-98 at 100kHz offset	-8	8-µMAX	Yes	Guaranteed frequency tuning range, integrated tank, shutdown mode, differential output	802.11, HomeRF, Bluetooth, cordless, 2.4GHz ISM	1.78 1.69
GENERAL-PURPOSE RF AMPLIFIERS										
MAX2611	4.5 to 6.5	DC to 1100	18.5 at 16	3	3.5	4-SOT143	Yes	Wideband gain block, low noise and high output capability	Satellite receivers, TV tuners, wireless LANs, ISM-band radios	0.66**
MAX2630	2.7 to 5.5	100 to 1000	13.7 at 7	-11	3.7	4-SOT143	Yes	3V LNA with internal biasing	Portable phones, wireless LANs, ISM-band radios	0.70**
MAX2631	2.7 to 5.5	100 to 1000	13.7 at 7	-11	3.7	5-SOT23	Yes	3V LNA with shutdown, no external bias resistor	Cordless phones, wireless LANs, ISM-band radios	0.74**
MAX2632	2.7 to 5.5	100 to 1000	13.7 at 7	-11	3.7	5-SOT23	Yes	3V LNA with bias control	ISM-band radios	0.74**
MAX2633	2.7 to 5.5	100 to 1000	13.7 at 7	-11	3.7	6-SOT23	Yes	3V LNA with shutdown and bias control	Cordless phones, wireless LANs, ISM-band radios	0.79**
MAX2650	4.5 to 5.5	DC to 1000	19 at 18	0	3.9	4-SOT143	Yes	5V LNA with internal biasing	Satellite receivers, TV tuners, wireless LANs, ISM-band radios	0.66**
LOW-NOISE AMPLIFIERS										
MAX2374	2.7 to 5.5	800 to 1000	8.5/4.5	15	1.5	6-LUCSP	Yes	14dB gain step	CDMA cellular phones, direct conversion receivers	0.89
MAX2640	2.7 to 5.5	400 to 1500	3.5	15.1 (900MHz)	0.9	6-SOT23	Yes	SiGe ultra-low-noise amplifier	Cordless phones, cellular, ISM-band radios	0.80**
MAX2641	2.7 to 5.5	1400 to 2500	3.5	14.4 (1.9GHz)	1.3	6-SOT23	Yes	SiGe ultra-low-noise amplifier	GPS, PCS, WLAN, HomeRF, ISM-band radios	0.80**
MAX2642/3	2.7 to 5.5	800 to 1000	2.6 to 5.3	17	1.35	6-SC70	Yes	Adjustable IP3/bias, 13dB gain step, shutdown mode, integrated output 50Ω match	ISM-band radios 900MHz, ISM, GSM, TDMA, PMR, cordless ISM-band radios	0.89**

† Prices provided are for design guidance and are FOB USA. International prices will differ due to local duties, taxes, and exchange rates. Not all packages are offered in 1k increments, and some may require minimum order quantities.

** 2500 pc. factory-direct price, FOB USA. Factory-direct orders are accepted only in multiples of 2500 or 10,000 pieces (smaller quantities are available from distributors).

Wireless/RF Products (continued)

Part Number	Supply Voltage (V)	Frequency Range (MHz)	Supply Current (mA)	Gain (dB)	Noise Figure (dB)	Input IP3 (dBm)	Pins- Package	EV Kit	Features	Applications	Price† 1000-up (\$)
LOW-NOISE AMPLIFIERS											
MAX2644	2.7 to 5.5	2400 to 2500	7.0	17	2.0	-3	6-SC70	Yes	Adjustable IP3/bias, shutdown mode, integrated output 50Ω match	Bluetooth, 802.11, HomeRF, 2.4GHz cordless, W-CDMA, satellite radio, MMDS	0.89
MAX2645	3.0 to 5.5	3400 to 3800	9.2	14.4	2.3	+4	10-μMAX-EP	Yes	Adjustable IP3/bias, 24dB gain step, shutdown mode	Wireless broadband, WLL, microwave radios	1.25
MAX2648	2.7 to 3.6	5000 to 6000	12.3	17.4	1.8	0	6-UCSP	Yes	Chip-scale package	802.11a, HiperLAN2, 5GHz ISM, microwave radios	1.25
MAX2651	2.7 to 3.3	925 to 960/ 1805 to 1990	5.9/5.7	18	1.2/ 1.8	-8.5	10-μMAX	Yes	Dual LNA (GSM & DCS/PCS band), 20dB gain step	GSM/DCS or GSM/PCS dual-band phones, GSM/DCS/PCS triple-band phones	1.27
MAX2652	2.7 to 3.3	925 to 960/ 1805 to 1990	7.2/7.0	18	1.3/ 1.8	-7	10-μMAX	Yes	Dual LNA (GSM & DCS/PCS band), 20dB gain step, shutdown mode	GSM/DCS or GSM/PCS dual-band phones, GSM/DCS/PCS triple-band phones	1.27
MAX2653	2.7 to 3.3	1805 to 1990	5.4	18	1.7	-8.5	8-μMAX	Yes	Single LNA (DCS/PCS band), 20dB gain step, shutdown mode	DCS1800 or PCS1900 single-band phones, GSM/DCS/PCS triple-band phones	1.19
MAX2654	2.7 to 5.5	1400 to 1700	5.8	15.1	1.5	-7.2	6-SC70	Yes	Shutdown mode, integrated output 50Ω match	GPS	0.89
MAX2655	2.7 to 5.5	1400 to 1700	8.3	14.1	1.5	+2.8	6-SC70	Yes	Adjustable IP3/bias, shutdown mode, integrated output 50Ω match	GPS receiver in cell phones, satellite phone, PDC	0.89
MAX2656	2.7 to 5.5	1800 to 2000	11.5	13.5	1.9	+1.5	6-SC70	Yes	Adjustable IP3/bias, 13dB gain step, shutdown mode, integrated 50Ω match	PCS, DCS, WLL	0.89
VCO BUFFER AMPLIFIERS											
MAX2470	2.7 to 5.5	10 to 500	15 at 5.5	15 at 5.5	75	6-SOT23	Yes	Single-ended input, diff. output, selectable frequency range	Cellular, PCS, ISM-band radios, active baluns		0.75**
MAX2471	2.7 to 5.5	10 to 500	16 at 5.5	16 at 5.5	74	6-SOT23	Yes	Differential input and output	Cellular, PCS, ISM-band radios, active baluns		0.75**
MAX2472	2.7 to 5.5	500 to 2500	10.2 at 5.2	10.2 at 5.2	50	6-SOT23	Yes	Dual open-collector outputs	Cellular, PCS, ISM-band radios, general oscillator buffering		0.80**
MAX2473	2.7 to 5.5	500 to 2500	11.8 at 3.3	11.8 at 3.3	50	6-SOT23	Yes	Single collector output, variable output power control	Cellular, PCS, ISM-band radios, general oscillator buffering		0.80**

† Prices provided are for design guidance and are FOB USA. International prices will differ due to local duties, taxes, and exchange rates. Not all packages are offered in 1k increments, and some may require minimum order quantities.

†† Future product—contact factory for pricing and availability. Specifications are preliminary.

** 2500 pc. factory-direct price, FOB USA. Factory-direct orders are accepted only in multiples of 2500 or 10,000 pieces (smaller quantities are available from distributors).

Rail-to-Rail is a registered trademark of Nippon Motorola, Ltd.

Wireless/RF Products (continued)

Part Number	Supply Voltage (V)	RF Frequency (MHz)	Baseband Bandwidth (MHz min)	Output Power (dBm)	Power Control (dB min)	Pins-Package	EV Kit	Features	Applications	Price [†] 1000-up (\$)
BASEBAND-TO-RF TRANSMITTERS (continued)										
MAX2360	2.7 to 5.5	800 to 1000/ 1800 to 2500	5	+7 (-54dBc ACPR)	90	48-TQFP-EP	Yes	I/Q modulator, dual IF VCOs, IF and RF PLL, upconverter, 3 PA drivers	Dual-band CDMA, TDMA, GSM, UMTS, and EDGE phones	5.99
MAX2362	2.7 to 5.5	1800 to 2500	5	+7 (-54dBc ACPR)	90	48-TQFP-EP	Yes	I/Q modulator, IF VCO, IF and RF PLL, upconverter, 2 PA drivers	PCS-band CDMA, TDMA, W-CDMA, and UMTS phones	5.85
MAX2364	2.7 to 5.5	800 to 1000	5	+7 (-54dBc ACPR)	90	48-TQFP-EP	Yes	I/Q modulator, IF VCO, IF and RF PLL, upconverter, 1 PA driver	Cellular-band CDMA and TDMA phones	5.85
MAX2366	2.7 to 5.5	800 to 1000/ 1800 to 2500	5	+7 (-54dBc ACPR)	90	48-QFN	Yes	I/Q modulator, dual IF VCOs, IF and RF PLL, upconverter, 3 PA drivers	Dual-band CDMA, TDMA, GSM, UMTS, and EDGE phones	5.99
MAX2361	2.7 to 5.5	800 to 1000/ 1800 to 2500	5	+10 (-54dBc ACPR)	90	48-QFN	Yes	Pin-compatible upgrade for MAX2366	Dual-band CDMA, TDMA, GSM, UMTS, and EDGE phones	††
MAX2363	2.7 to 5.5	1800 to 2500	5	+10 (-54dBc ACPR)	90	48-QFN	Yes	Pin-compatible upgrade for MAX2367	PCS-band CDMA, TDMA, W-CDMA, and UMTS phones	††
MAX2365	2.7 to 5.5	800 to 1000	5	+10 (-54dBc ACPR)	90	48-QFN	Yes	Pin-compatible upgrade for MAX2368	Cellular-band CDMA and TDMA phones	††
MAX2367	2.7 to 5.5	1800 to 2500	5	+7 (-54dBc ACPR)	90	48-QFN	Yes	I/Q modulator, IF VCO, IF and RF PLL, upconverter, 2 PA drivers	PCS-band CDMA, TDMA, W-CDMA, and UMTS phones	5.85
MAX2368	2.7 to 5.5	800 to 1000	5	+7 (-54dBc ACPR)	90	48-QFN	Yes	I/Q modulator, IF VCO, IF and RF PLL, upconverter, 1 PA driver	Cellular-band CDMA and TDMA phones	5.85
MAX2720	2.7 to 3.3	1700 to 2100	40	-8.5 (modulator), +12.5 (PA driver)	35	20-TSSOP-EP	Yes	Direct I/Q modulator, selectable LO doubler, VGA, PA driver, shutdown	WLL, wideband CDMA systems, basestations, LMDS/MMDS	3.23
MAX2721	2.7 to 3.3	2100 to 2500	40	-5 (modulator), +11 (PA driver)	32	20-TSSOP-EP	Yes	Direct I/Q modulator, selectable LO doubler, VGA, PA driver, shutdown	WLL, wideband CDMA systems, basestations, LMDS/MMDS 2.4GHz ISM	3.23
RF-TO-BASEBAND RECEIVERS										
MAX2700	2.7 to 3.3	1800 to 2100	56	>75	48-TQFP-EP	Yes	Yes	LNA with selectable gain and shutdown, wideband LO quad generator, baseband gain correction	Wireless local loop, wireless broadband access	4.95
MAX2701	2.7 to 3.3	2100 to 2500	56	>75	48-TQFP-EP	Yes	Yes	LNA with selectable gain and shutdown, wideband LO quad generator, baseband gain correction	Wireless local loop, wireless broadband access, MMDS, 2.4GHz ISM	4.95

† Prices provided are for design guidance and are FOB USA. International prices will differ due to local duties, taxes, and exchange rates. Not all packages are offered in 1k increments, and some may require minimum order quantities.

†† Contact factory for pricing.

* Temperature Ranges: C = 0°C to +70°C, I = -25°C to +85°C, E = -40°C to +85°C, M = -55°C to +125°C.

Wireless/RF Products (continued)

Part Number	Supply Voltage (V)	Resolution (Bits)	Input Channels	Sample Rate (MSPS)	Conversion Time (μ s)	Voltage Reference (V)	Data-Bus Interface	EV Kit	Features	Price [†] 1000-up (\$)
DATA CONVERTERS										
MAX104	5	8	1	1000	–	Internal	Parallel	Yes	7.3 ENOB at 500MHz f _{in} , demuxed outputs	††
MAX106	±5	8	1	600	–	Internal	Parallel	Yes	High-performance ADC, demuxed outputs	††
MAX108	±5	8	1	1500	–	Internal	Parallel	Yes	47dB SNR at 750MHz f _{in} , demuxed outputs	††
MAX1002	5	6	2	60	–	Internal	Parallel	Yes	I/Q ADC, internal oscillator, PGA	3.40
MAX1003	3.3 to 5.5	6	2	90	–	Internal	Parallel	Yes	I/Q ADC, internal oscillator, PGA	3.96
MAX1005	2.7 to 5.5	5-ADC/7-DAC	1	15	–	Internal	Parallel	–	IF undersampler, ADC/IF subcarrier DAC for use with MAX2411/AMAX2511	2.96
MAX1007	2.85 to 3.6	8-ADC/7-DAC	4	–	5.2	Internal	Serial	–	Mobile radio controller with one ADC and four DACs	4.01
MAX1425	5	10	1	10	–	Internal/External	Parallel	Yes	High-performance, low-power ADC with ref	3.00
MAX1426	5	10	1	20	–	Internal/External	Parallel	Yes	High-performance, low-power ADC with ref	3.95
Part Number	Supply Voltage (V)	Supply Current (mA)	Shutdown Supply Current (μA)	Slew Rate (V/μs)	Enable Time (μs)	Open-Loop Gain (dB)	Pins- Package	Price[†] 1000-up (\$)		
PA POWER CONTROL										
MAX4473	2.7 to 6.5	2	1	1.8	1.5	80	8- μ MAX		RF PA power-control IC for GSM applications with Rail-to-Rail [®] I/O	1.20
Part Number	Input Voltage Range (V)	Output Voltage (V)	Quiescent Supply Current (mA), max(typ)	Output (A)	Control Scheme	Pins- Package	Temp. Ranges*	EV Kit	Features	Price[†] 1000-up (\$)
PA POWER SUPPLIES										
MAX1687/1688	2.7 to 6	1.25 to 6	4(2)	3 (burst)	PFM	8-SO, 16-TSSOP	E	Yes	Step-up switching regulator with adaptive control scheme, ideal for GSM handsets	2.20

† Prices provided are for design guidance and are FOB USA. International prices will differ due to local duties, taxes, and exchange rates. Not all packages are offered in 1k increments, and some may require minimum order quantities.

†† Contact factory for pricing.

* Temperature Ranges: C = 0°C to +70°C, I = -25°C to +85°C, E = -40°C to +85°C, M = -55°C to +125°C.