

### General Description

The MM5450 and MM5451 LED display drivers are monolithic MOS IC's fabricated in an N-Channel, metal-gate process. The technology produces low-threshold, enhancement-mode, and ion-implanted depletion-mode devices.

A single pin controls the LED display brightness by setting a reference current through a variable resistor connected to the supply.

### Applications

- Industrial control indicator
- Relay driver
- Digital clock, thermometer, counter, voltmeter
- Instrumentation readouts

### Features

- Continuous brightness control
- Serial data input
- No load signal requirement
- Enable (on MM5450)
- Wide power supply operation
- TTL compatibility
- 34 or 35 outputs, 15mA capability
- Alphanumeric capability

### Ordering Information

Part Number	Temp. Range	Package
MM5450BN	-40 to +85°C	40-pin Plastic DIP
MM5451BN	-40 to +85°C	40-pin Plastic DIP
MM5450BV	-40 to +85°C	44-pin PLCC
MM5451BV	-40 to +85°C	44-pin PLCC

### Block Diagram

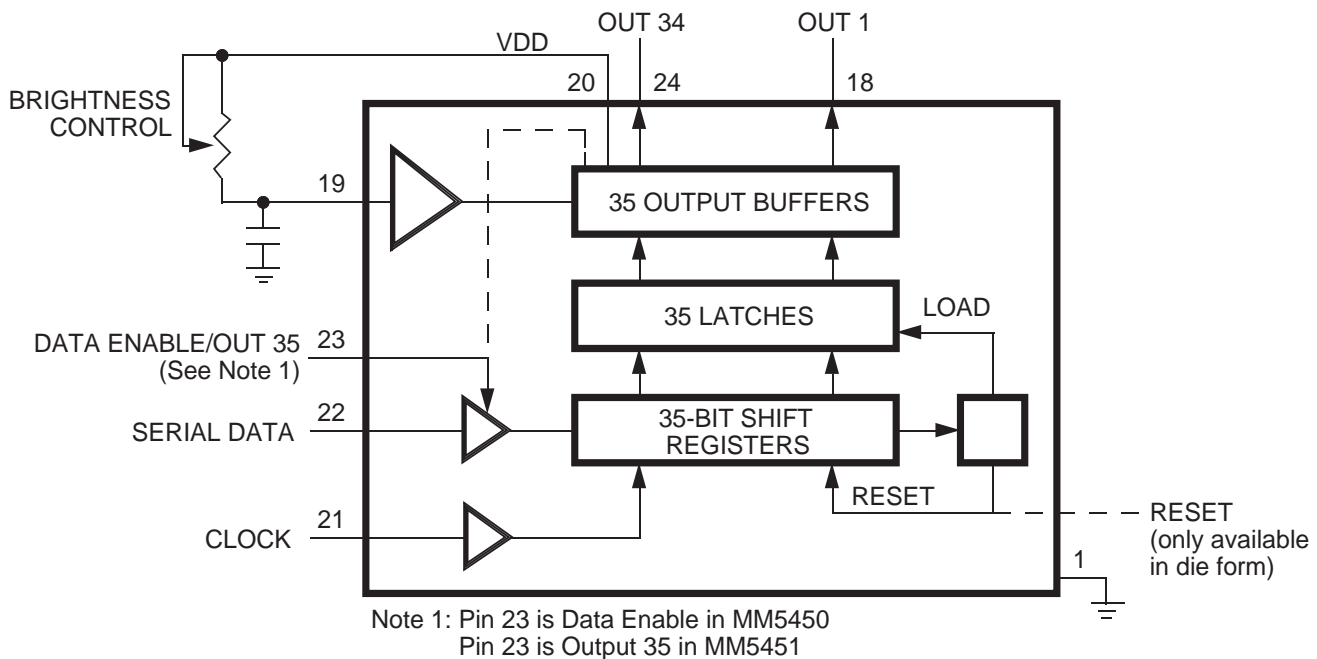
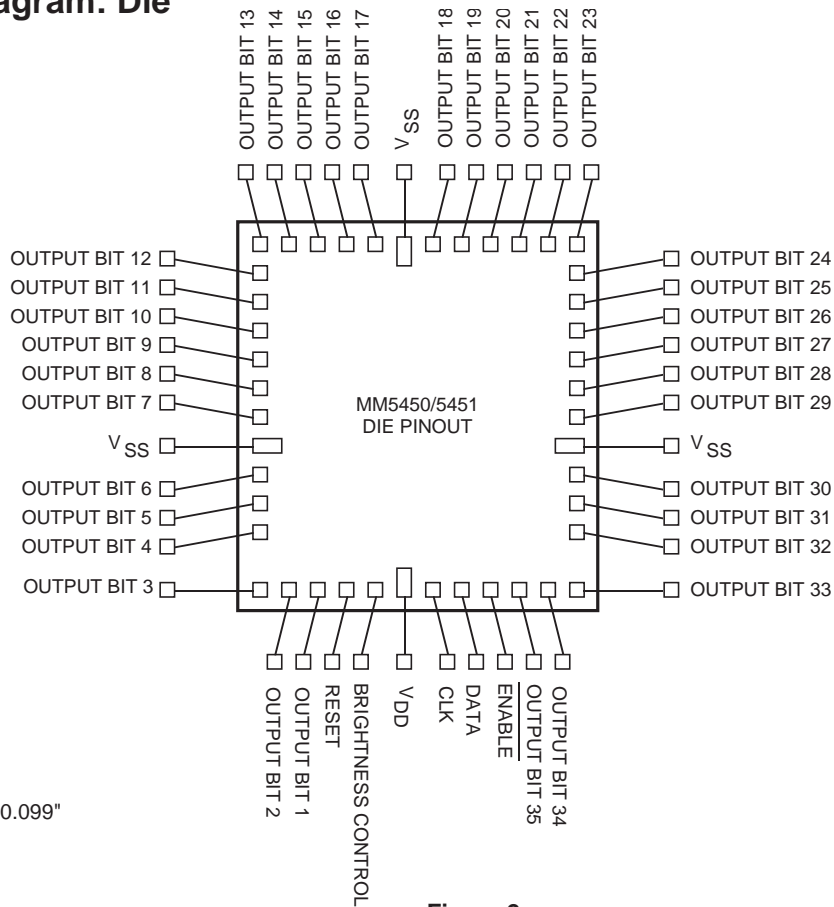

Figure 1.

### Connection Diagram: Die



Note: Die size is 0.106" x 0.099"

Figure 2.

### Connection Diagram: Dual-in-line Package

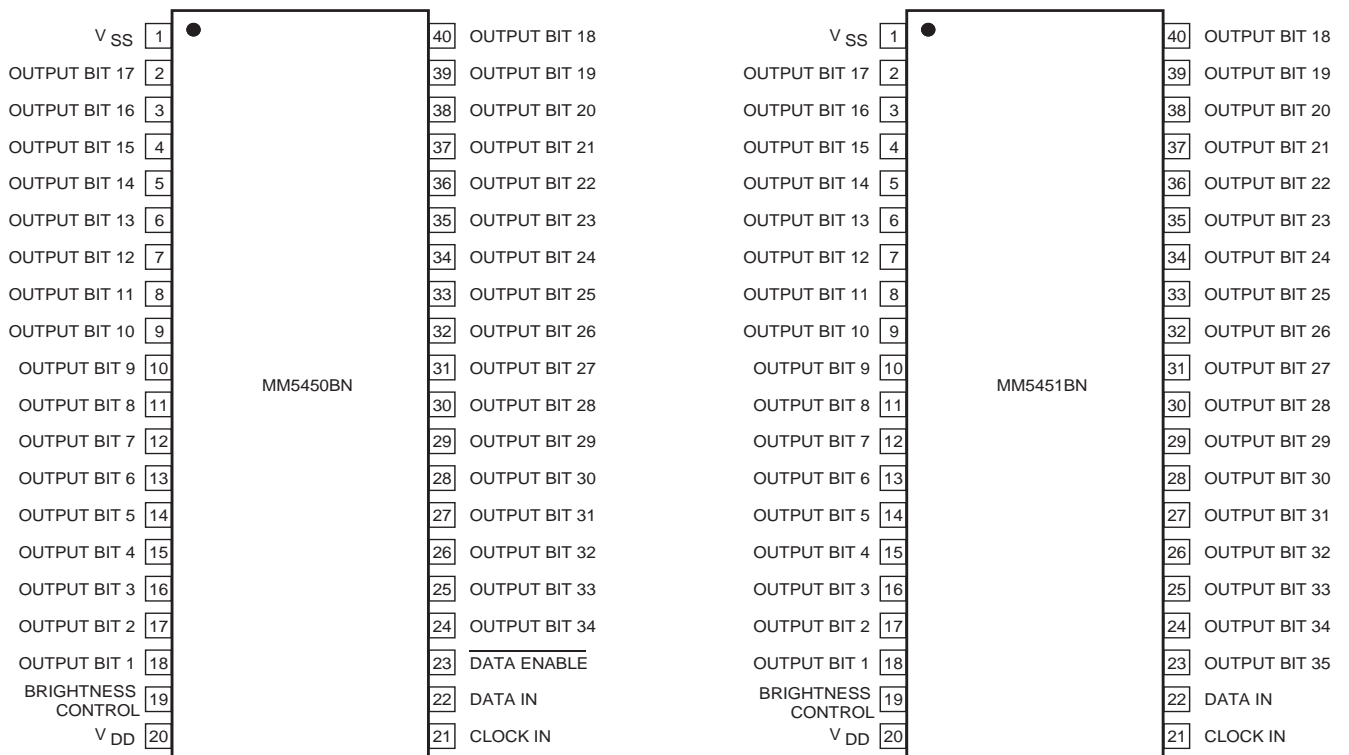

Figure 3a, 3b.

# Connection Diagram: Plastic Leaded Chip Carrier

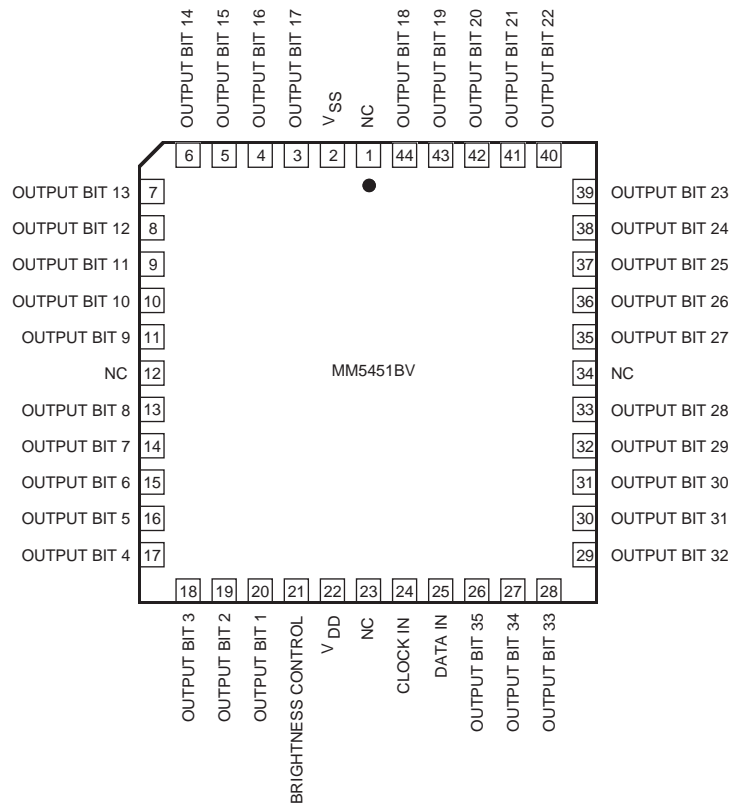
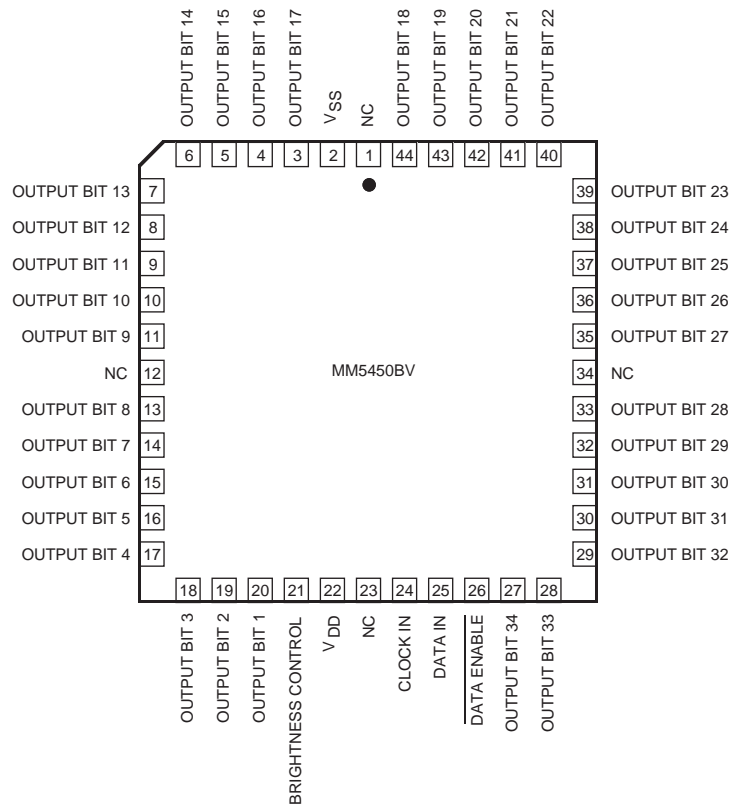

Figure 4a, 4b.

## Absolute Maximum Ratings

Voltage (any pin) .....	$V_{SS}$ to $V_{SS} + 12V$
Power Dissipation ( $P_D$ )	
+25°C .....	1W
+85°C .....	560mW
Junction Temperature ( $T_J$ ) .....	+150°C
Storage Temperature ( $T_S$ ) .....	-65°C to +150°C
Lead Temperature (soldering, 10 sec.) .....	+300°C

## Operating Ratings

Supply Voltage ( $V_{DD} - V_{SS}$ ) .....	+4.75V to +11V
Ambient Temperature Range ( $T_A$ ) .....	-40°C to +85°C

## Electrical Characteristics

4.5V  $\leq V_{DD} \leq 11V$ ,  $V_{SS} = 0V$ ;  $T_A = 25^\circ C$ , **bold** values indicate  $-40^\circ C \leq T_A \leq +85^\circ C$ ; unless noted

Symbol	Parameter	Condition	Min	Typ	Max	Units
	Power Supply Current	-25°C to +85°C, excluding output loads -40°C to +85°C, excluding output loads			<b>8.5</b> <b>10</b>	mA mA
$V_L$ $V_H$	Data Input Voltage	logic-0 level, $\pm 10\mu A$ input bias logic-1 level, $4.75V \leq V_{DD} \leq 5.25V$ $V_{DD} > 5.25V$	<b>-0.3</b> <b>2.2</b> $V_{DD}-2$		<b>0.8</b> $V_{DD}$ $V_{DD}$	V V V
	Brightness Control Input Current	<b>Note 2</b>	<b>0</b>		<b>0.75</b>	mA
	Output Sink Current	segment off, $V_{OUT} = 3.0V$ segment on, $V_{OUT} = 1.0V$ , <b>Note 3</b> brightness input = $0\mu A$ brightness input = $100\mu A$ brightness input = $750\mu A$	<b>0</b> <b>0</b> <b>2.0</b> <b>15</b>	2.7	<b>10</b> <b>15</b> <b>10</b> <b>4</b> <b>25</b>	$\mu A$ mA $\mu A$ mA mA
	Brightness Control Input Voltage	input current = $750\mu A$	<b>3.0</b>		<b>4.3</b>	V
	Output Matching	<b>Note 1</b>			$\pm 20$	%
$f_C$	Clock Input Frequency	<b>Notes 5, 6</b>			<b>500</b>	kHz
$t_H$	Clock Input High Time	<b>Notes 5, 6</b>	<b>950</b>			ns
$t_L$	Clock Input Low Time	<b>Notes 5, 6</b>	<b>950</b>			ns
$t_{DS}$	Data Input Setup Time		<b>300</b>			ns
$t_{DH}$	Data Input Hold Time		<b>300</b>			ns
$t_{DES}$	Data Enable Input Setup Time		<b>100</b>			ns
	Reset Pad Current	die	<b>8</b>			$\mu A$

**Note 1:** Output matching is calculated as the percent variation  $(I_{MAX} + I_{MIN}) \div 2$ .

**Note 2:** With a fixed resistor on the brightness input pin, some variation in brightness will occur among devices. Maximum brightness control input current can be 2mA providing it complies with Note 3 and the junction temperature equation.

**Note 3:** See Figures 7, 8 and 9 for recommended operating conditions and limits. Absolute maximum for each output should be limited to 40mA.

**Note 4:**  $V_{OUT}$  should be regulated by the user. See Figures 8 and 9 for allowable  $V_{OUT}$  vs.  $I_{OUT}$  operation.

**Note 5:** AC input waveform specification for test purpose:  $t_R \leq 20ns$ ,  $t_F \leq 20ns$ ,  $f = 500kHz$ , 50%  $\pm 10\%$  duty cycle.

**Note 6:** Clock input rise and fall times must not exceed 300ns.

## Functional Description

The MM5450 and MM5451 were designed to drive either 4- or 5-digit alphanumeric LED displays with the added benefit of requiring minimal interface with the display or data source.

Data is transferred serially via 2 signals; clock and serial data. Data transfer without the added inconvenience of an external load signal is accomplished by using a format of a leading "1" followed by the allowed 35 data bits. These 35 data bits are latched after the 36th has been transferred. This scheme provides non multiplexed, direct drive to the LED display. Characters currently displayed (thus, data output) changes only if the serial data bits differ from those previously transferred.

Control of the output current for LED displays provides for the display brightness. To prevent oscillations, a 1nF capacitor should be connected to pin 19, brightness control.

The block diagram is shown in Figure 1. For the MIC5450, the DATA ENABLE is a metal option and is used instead of the 35th output. The output current is typically 20-times greater that the current into pin 19, which is set by an external variable resistor.

There is an external reset connection shown which is available on unpackaged (die) only. Figure 2 illustrates the die pad locations for bonding in "chip on board" applications.

Figure 5 shows the input data format. A leading "1" is followed by 35 bits of data. After the 36th had been transferred, a LOAD signal is generated synchronously with the clock high state. This loads the 35 bits of data into the latches. The low side of the clock is used to generate a RESET signal which clears all shift registers for the next set of data. All shift registers are static master-slave, with no clear for the master portion of the first register, allowing continuous operation.

There must be a complete set of 36 clocks or the shift registers will not clear.

When the chip first powers ON, an internal power ON reset signal is generated which resets all registers and all latches. The START bit and the first clock return the chip to its normal operation.

Figure 3 and 4 show the pin-out of the MIC5450 and MIC5451. Bit 1 is the first bit following the start bit and it will appear on pin 18. A logical "1" at the input will turn on the appropriate LED.

Figure 5 shows the timing relationships between data, clock and DATA ENABLE. A maximum clock frequency of 0.5MHz is assumed.

For applications where a lesser number of outputs are used, it is possible to either increase the current per output, or operate the part at higher than 1V  $V_{OUT}$ . The following equation can be used for calculations.

$$T_J = (V_{OUT}) (I_{LED}) (\text{No. of segments}) (124^{\circ}\text{C/W}) + T_A$$

where:

$T_J$  = junction temperature + 150°C max

$V_{OUT}$  = the voltage at the LED driver outputs

$I_{LED}$  = the LED current

124°C/W = thermal resistance of the package

$T_A$  = ambient temperature

The above equation was used to plot Figures 7–9.

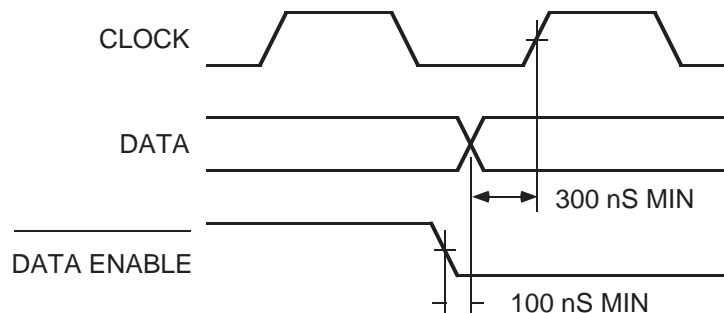

Figure 5.

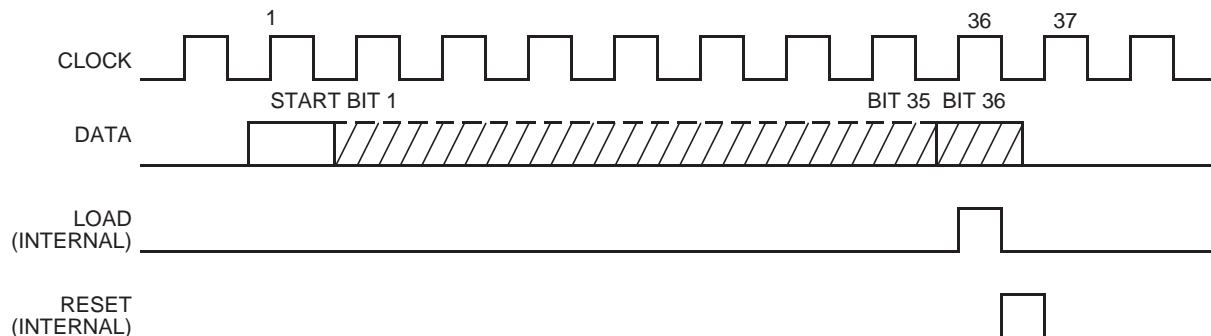

Figure 6. Input Data Format

### Typical Performance Characteristics

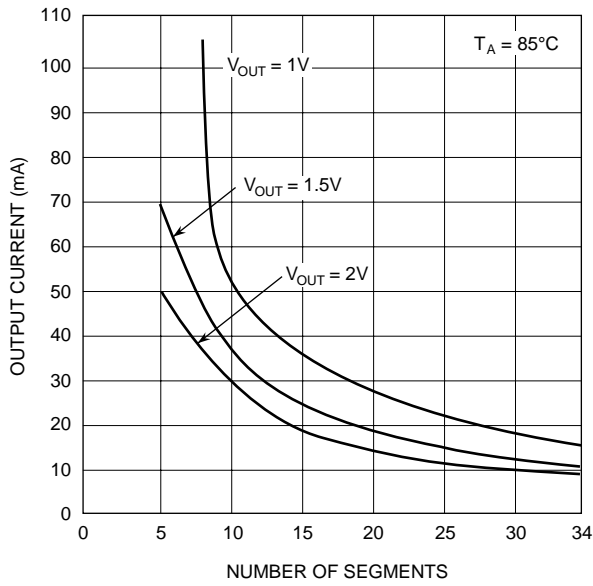

Figure 7.

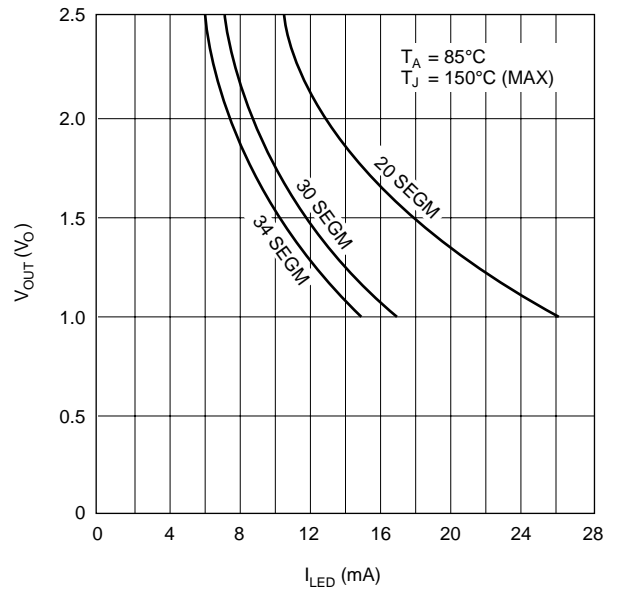

Figure 8.

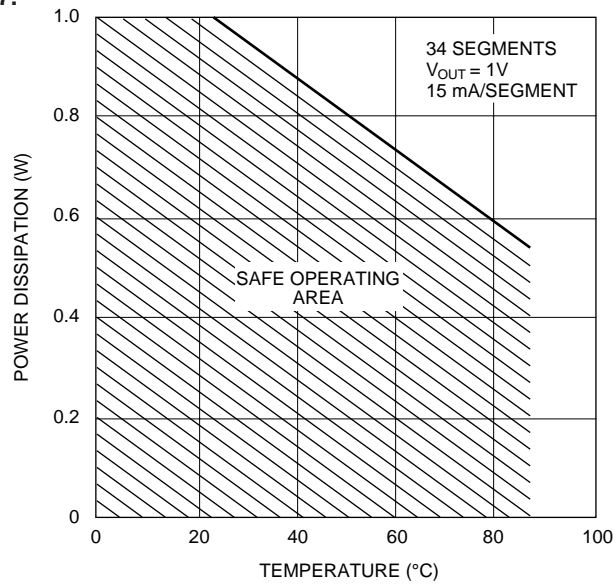

Figure 9.

### Typical Applications

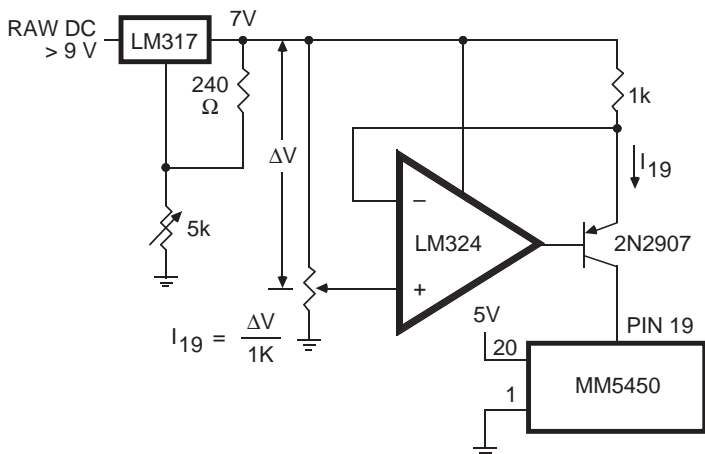

Figure 10. Typical Application of Constant Current Brightness Control

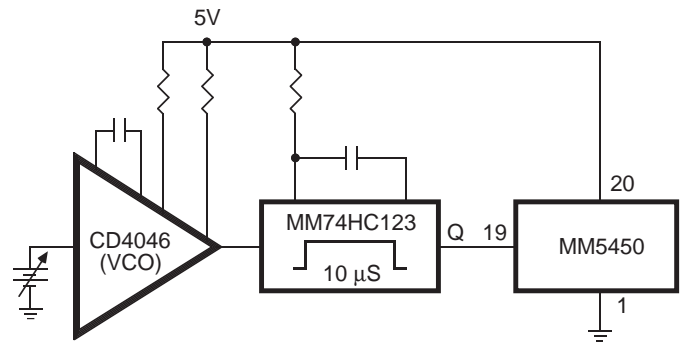

Figure 11. Brightness Control Varying the Duty Cycle

# Typical Applications

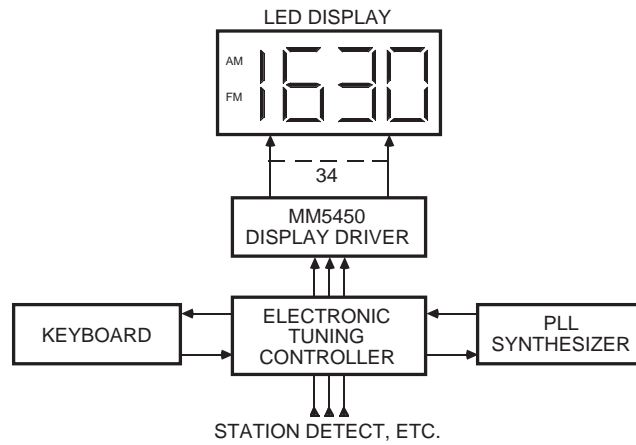

Figure 12. Basic Electronically Tuned Radio System

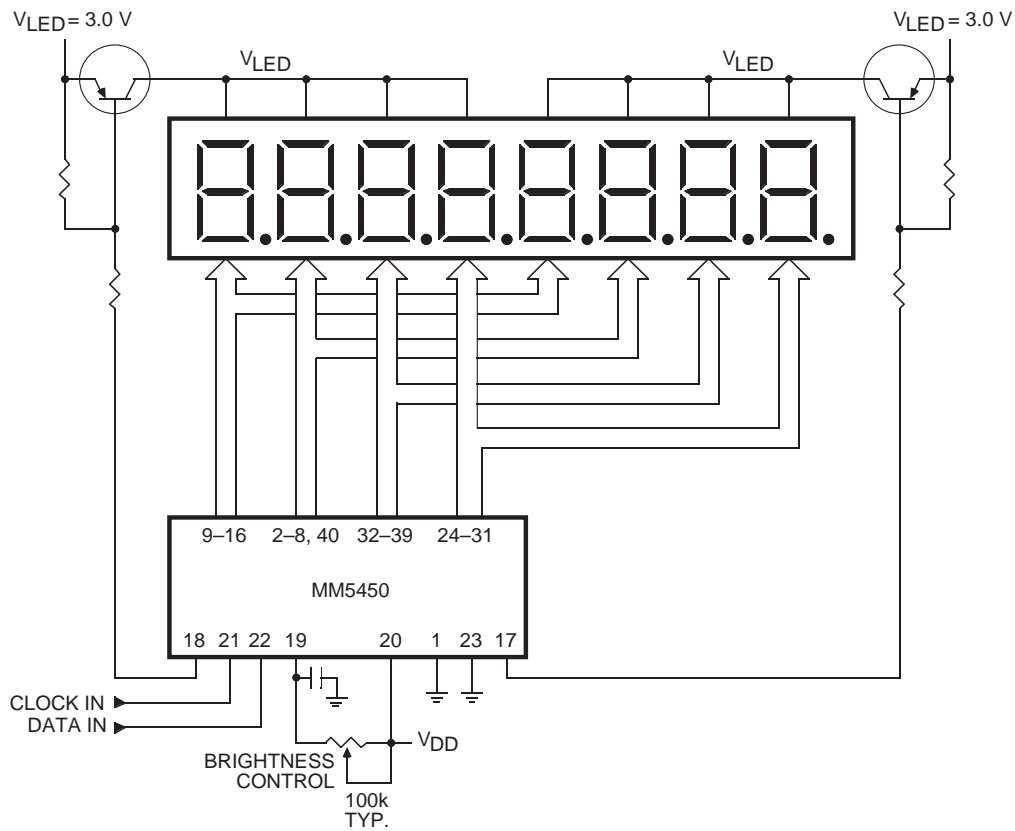

Figure 13. Duplexing 8 Digits with One MM5450.