

Generating Phase Controlled Sinewaves with the ML2036

Vince Cardinale

Introduction

The 16-bit resolution of the ML2036 combined with its Inhibit feature makes it a powerful tool for generating precision sinewaves. It can produce frequencies from DC to 50kHz in 1Hz increments with -40dB harmonic distortion *and* has the control to stop the output at any given time or at the next zero crossing, *with no external components*.

Precise phase control can also be obtained with the addition of a few external devices. With the addition of phase control two or more ML2036 sinewave generators can be synchronized at any angle from 0 to 360 with better than 1 degree resolution.

Inhibit Mode

In order to place the ML2036 in Inhibit mode three conditions must occur simultaneously. The three-level P_{DN}-INH input pin must be at the V_{SS} voltage (-5V), the shift register must be loaded with all zeros, and the LATI pin must be a logic "1" (+5V). Once these three conditions are met the output continues to operate until it reaches V_{OS} + |V_X| if the next zero crossing is positive going, or V_{OS} - |V_X| if the next zero crossing is negative going, and then holds this level (see figure 1). The output will stay at this voltage until a new frequency is loaded into the data latch, at which point the output will continue where it left off. If the output stopped at zero after approaching from below 0V then it will start-up going positive. If it stopped after approaching from above 0V then it will start-up going negative.

Initialization

In order to synchronize the ML2036 you must first initialize it so it will start up at a known point in the sinewave. By using the Inhibit mode you can stop the part at 0V but you can't be sure from which direction it approached zero, or more importantly which direction it will start-up. If you can guarantee that it stopped while approaching from below 0V then you can be sure it will start-up going positive. This can be done if the LATI pin is not allowed to be high when the output is above ground. The circuit in figure 2 and the following procedure demonstrate how this can be implemented.

Initialization Procedure

- 1) Power up
- 2) Set LAT high
- 3) Set INH low
- 4) Load MSB: **0001 0000 0000 0000** :LSB
- 5) Set LAT low
- 6) Wait at least 1 output cycle time
- 7) Load all 0s
- 8) Set INH high (INH must go high before LAT by at least a NAND gate delay)
- 9) Set LAT high
- 10) Wait at least 1.5 output cycle times
Output stops at 0V going high
- 11) Load desired frequency
- 12) Set LAT low
Output begins at 0V going high
- 13) Set INH low

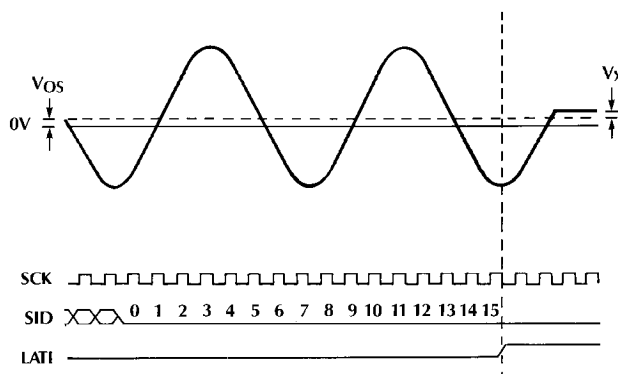

$$|V_X| = \frac{V_{PEAK}}{256}; \text{ For } f_{OUT} \leq \frac{f_{CLK}}{2048}$$

$$|V_X| \leq \frac{V_{PEAK}}{256} + V_{PEAK} \text{ Sine} \left(\frac{8\pi f_{OUT}}{f_{CLK}} + \frac{\pi}{512} \right)$$

$$\text{For } f_{OUT} > \frac{f_{CLK}}{2048}$$

Figure 1. Inhibit Mode

Application Note 12

Synchronization

At the completion of step 10 the part is initialized. Its output is stable at about 0V and will start up going positive. If you want to synchronize the output with some external event you can load the shift register with the desired frequency (step 11) and then set LAT low (step 12) synchronously with the external event. If you want to synchronize two ML2036 sinewave generators together initialize them both as described, and then set LAT low (step 12) on both circuits simultaneously.

Precise phase control between two parts can be achieved by initializing both parts, starting one and then waiting a known time before starting the other. For example, to produce two 5kHz sinewaves with 90° phase shift you should wait 50μs between starting each circuit. Since the ML2036 uses a 3MHz reference clock to update the output (assuming a 12MHz clock is used to drive CLK_{IN}) the phase resolution will be 0.6°. This resolution will vary from 0.0012° for two 10Hz signals to 6° for two 50kHz signals.

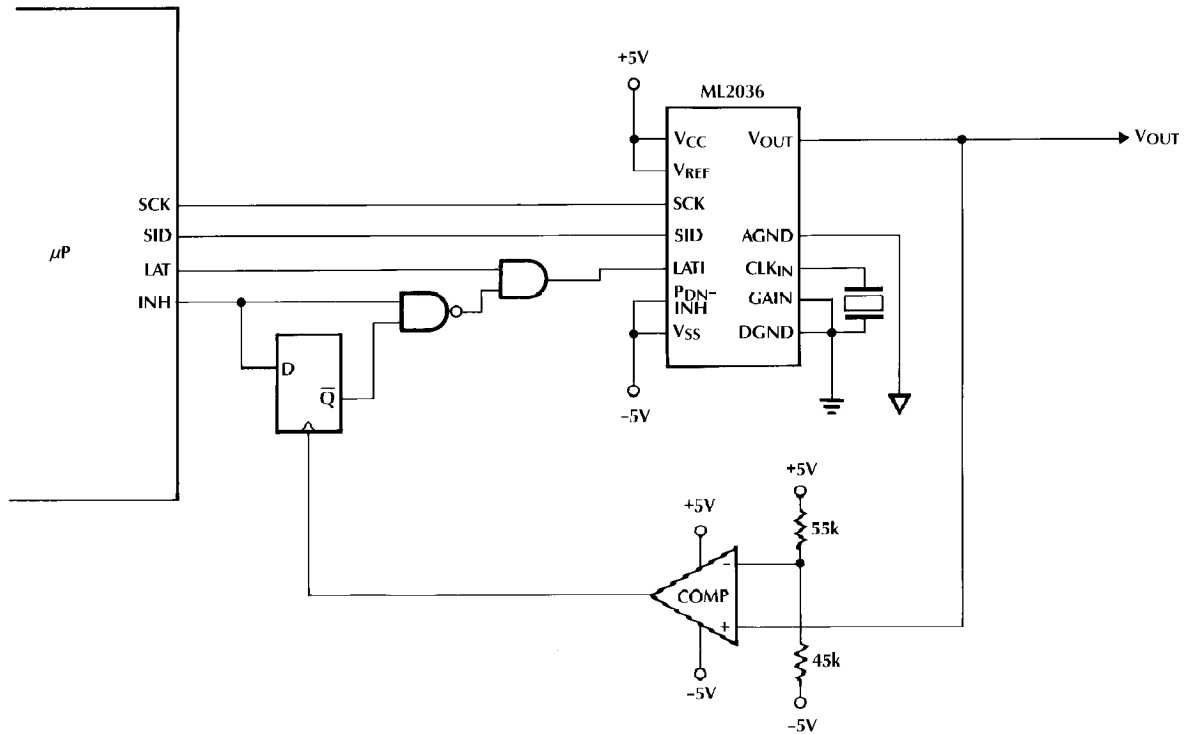

Figure 2.