DESIGN SHOWCASE

Step-up supply charges battery while serving load

The circuit of **Figure 1** supports the many portable applications in which a microprocessor (μP) or microcontroller (μC) controls charging of the battery. IC1 is a step-up switching regulator that boosts V_{IN} (nominally 5V) as necessary to supply the combination of charging current and load current. The 5V source must include short-circuit protection. IC2 is a high-side current-sense amplifier that monitors the charging current. Commands from the processor include CHARGE $\overline{\text{ON}}$ /OFF and $\overline{\text{FAST}}$ /TRICKLE CHARGE.

IC2 produces an output current (OUT) equal to 10^{-4} of the current through sense resistor R9. Q3 and Q4 are on during a fast-charge operation, so this output current flows through the parallel combination of R11 and (approximately) R4. The resulting feedback to IC1 (pin 3) maintains the fast-charge current through R9 at 500mA. This feedback also enables the regulator to supply as much as 500mA of load current in addition to the fixed 500mA of charging current. Q2 limits the battery voltage to 10V (2V/cell).

During the fast charge, an external processor and multi-channel A/D converter (ADC) must monitor the battery's terminal voltage. When the ADC senses a

change of slope in this voltage, the processor terminates the fast charge by asserting a high on $\overline{\text{FAST}}$ /TRICKLE CHARGE. Q3 turns off, causing a rise in the feedback (FB) that lowers the charging current to the trickle-charge rate (approximately 60mA).

If IC1 shuts down, or if load current plus charging current exceeds the capability of IC1, the R9 current reverses as current flows out of the battery. IC2 indicates the reversal by allowing R13 to pull its open-collector SIGN output high, turning off Q4 and turning on Q5. Current through R12 then produces a voltage proportional to the battery's discharge current (5A through R9 produces a full-scale response of 3V across R12).

By integrating this voltage over time (sampling at fixed intervals and multiplying by the time interval), the A/D-processor system can monitor energy removed from the battery. Based on this measurement and the terminal-voltage measurement, the processor can then re-initiate a fast charge (by asserting $\overline{\text{FAST}}$ /TRICKLE CHARGE low) before the battery reaches its end of life.

A related idea appeared in the 6/8/95 issue of EDN.

(Circle 6)

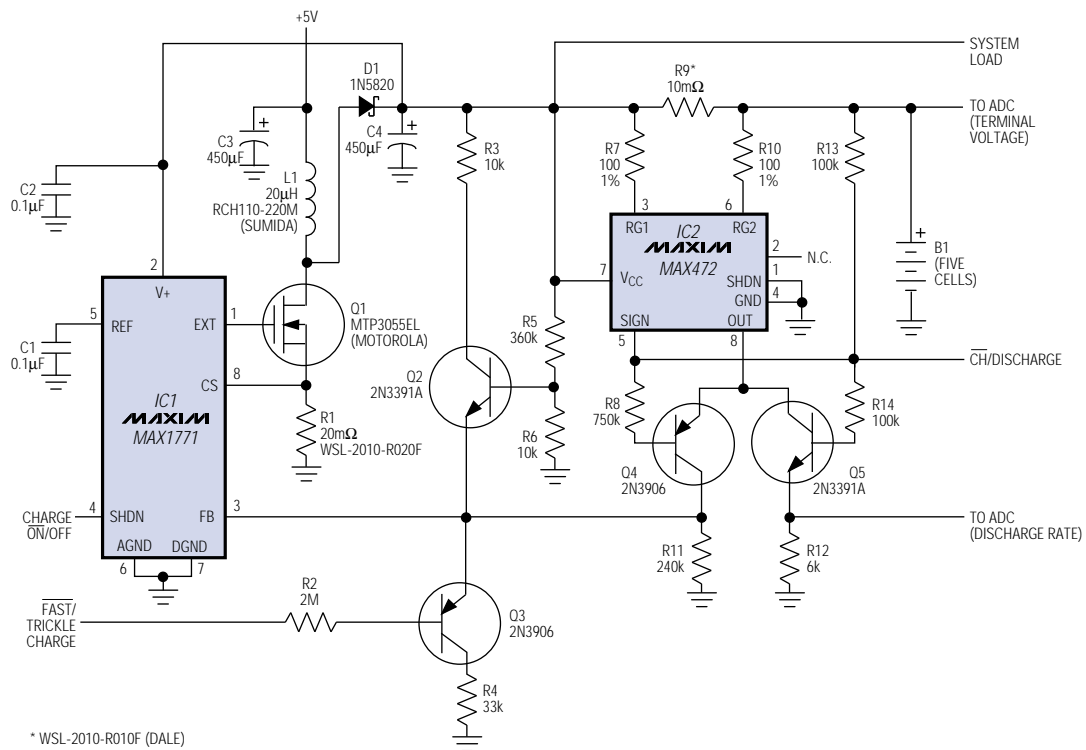

* WSL-2010-R010F (DALE)

Figure 1. This circuit controls charging of the battery while delivering current to the system load.